

THIS DRAWING IS UNPUBLISHED. RELEASED FOR PUBLICATION
 BY TYCO ELECTRONICS CORPORATION. ALL RIGHTS RESERVED.

LOC	DIST	REVISIONS		
P	LTR	DESCRIPTION	DATE	BY
AJ	00	REV PER EDD 07-027471	1/16/2008	DW JL

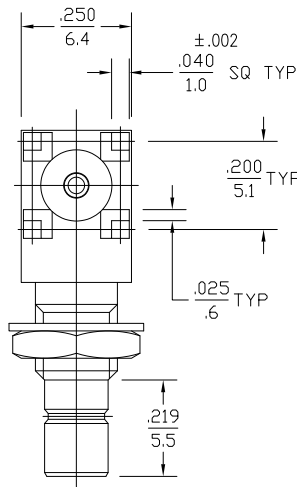
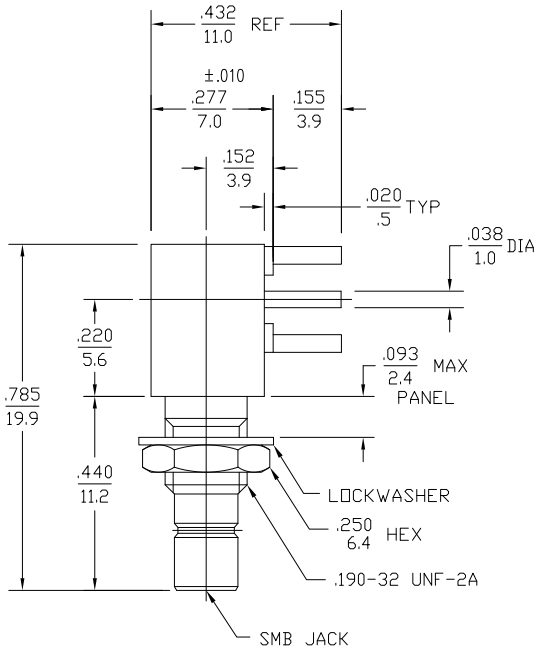

1060469-1
 PART NUMBER

COMPONENT	MATERIAL	FINISH
HOUSING, CAP, CENTER CONTACT & MOUNTING NUT	BRASS PER ASTM-B-16, HALF HARD	GOLD PLATE PER MIL-G-45204
DIELECTRIC	TFE FLUOROCARBON PER ASTM-D-1457	N/A
LOCKWASHER	PHOSPHOR BRONZE PER QQ-B-750, GRADE B2 OR TIN BRASS PER ASTM-B-591	GOLD PLATE PER MIL-G-45204

.XXX = in
 XX.X = mm

NOTES:
 1. CAPTURED CENTER CONTACT

THIS DRAWING IS A CONTROLLED DOCUMENT.		DATE: 6/14/05	BY: J. KULLA
DIMENSIONS: INCHES		DATE: 6/24/05	BY: J. JONES
OTHER DIMENSIONS: MILLIMETERS		DATE: 6/25/05	BY: J. JONES
MATERIAL: -		FINISH: -	APPROVAL: -
FINISH: -		APPLICATION SPEC: -	SIZE: A2
CUSTOMER DRAWING		WEIGHT: -	CAGE CODE: 00779
		SCALE: 4:1	DRAWING NO: 1060469-1
		SHEET: 1 of 1	REV: C