

REV	DATE	DESCRIPTION	BY	CHK	APP
AJ	16	PER EC 0514-0184-04			

- △ ZINC PER QQ-Z-363.
- △ POLYMETHYLPENTENE PER ASTM-D-1238.
- △ PHOSPHOR BRONZE PER QQ-B-750.
- △ BRASS PER ASTM-B-453.
- △ BRASS PER ASTM-B-16.
- △ NICKEL PLATE PER QQ-N-290, 3.81 μm [.000150] MINIMUM THICK.
- △ TIN PLATE PER ASTM B 545, 3.81 μm [.000150] MINIMUM THICK.
- △ GOLD PLATE PER MIL-G-45204, 0.76 μm [.000030] MINIMUM THICK.
- 9. USE INSTRUCTION SHEET 2769.

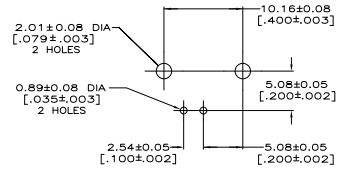
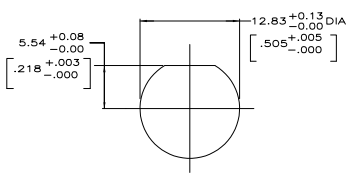
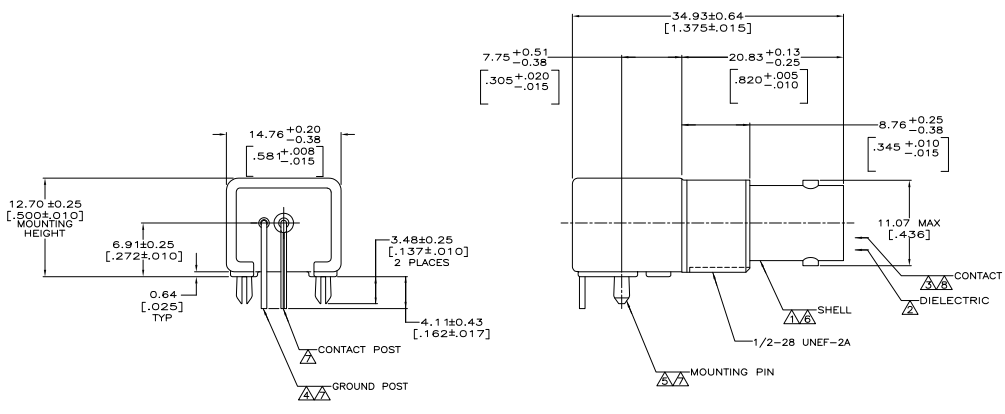

415417-1  
PART NUMBER

THIS DRAWING IS A CONTROLLED DOCUMENT.		DESIGNED BY: MICHAEL E. CONROY	DATE: 10/20/08	REVISED BY: MICHAEL J. TONGIAUX	DATE: 10/20/08	REVISED BY: MICHAEL J. TONGIAUX	DATE: 10/20/08	REVISED BY: MICHAEL J. TONGIAUX	DATE: 10/20/08
APPROVED BY: [Signature]	DATE: 10/20/08	DESIGNED BY: MICHAEL E. CONROY	DATE: 10/20/08	REVISED BY: MICHAEL J. TONGIAUX	DATE: 10/20/08	REVISED BY: MICHAEL J. TONGIAUX	DATE: 10/20/08	REVISED BY: MICHAEL J. TONGIAUX	DATE: 10/20/08
SEE NOTES		SEE NOTES		SEE NOTES		SEE NOTES		SEE NOTES	
CUSTOMER DRAWING		A100779		415417		415417		415417	