

THIS DRAWING IS UNPUBLISHED
 RECEIVED FOR REPRODUCTION
 © 1988 TTI ELECTRONICS CORPORATION ALL RIGHTS RESERVED

REV	DATE	DESCRIPTION	BY	CHK	APP
16		REVISED PER ECO-06-018704	E1		

- △ USE CRIMP TOOL: 354940-1
- 2. PANEL THICKNESS = 5.08 [200] MAX
- 3. USE INSTRUCTION SHEET 408-4048
- 4. CAPACITANCE = 9400 PF ± 10% TOTAL
VOLTAGE = 500 VDC

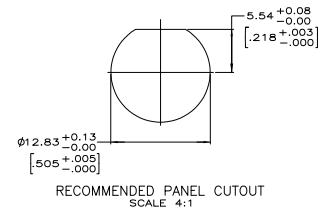
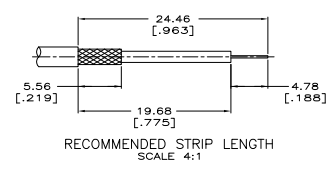
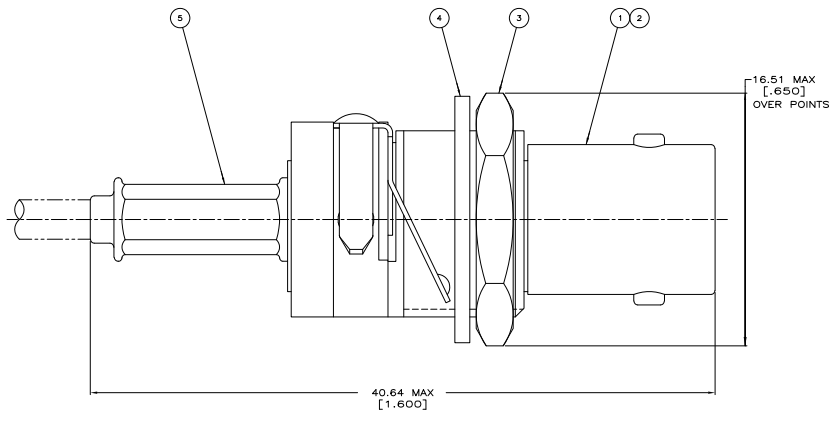

RC-174/U, 188/U, 316/U	4.52 [.178]	1.73 [.068]	58436-3	227194-S	9-413858-0	1-329632-2	1-329631-2	1-413774-5	414757-2	414758-2
OBSOLETE RG-58/U, 58A/U, 58B/U, 58C/U	5.41 [.213]	1.73 [.068]	58436-1		9-221132-0	1-329632-2	1-329631-2	413774-5	414757-1	414758-1
FOR USE WITH CABLE	FERRULE	CENTER CONTACT	DIE SET	⑥ SPACER	⑤ FERRULE	④ LOCK WASHER	③ JAM NUT	② CONTACT	① JACK ASSEMBLY	PART NUMBER
	HEX CRIMP HEIGHTS		△	QTY=1	QTY=1	QTY=1	QTY=1	QTY=1	QTY=1	

THIS DRAWING IS A CONTROLLED DOCUMENT

DESIGNED BY	J. E. CONNER	DATE	108-1490
CHECKED BY	M. PHILLIPS	DATE	108-1490
APPROVED BY	M. PHILLIPS	DATE	108-1490
DATE	108-1490	DRAWING NO.	4114758
CUSTOMER DRAWING		REV	1

TTI Electronics Corporation
 Harrisburg, PA 17105-3608

JACK, BULKHEAD, DECOUPLER, 50 OHM, HEX CRIMP, ENG