

4

3

2

1

THIS DRAWING IS UNPUBLISHED. RELEASED FOR PUBLICATION JULY, 2006.
 © COPYRIGHT 2006 BY TYCO ELECTRONICS CORPORATION. ALL RIGHTS RESERVED.

LOC	DIST	REVISIONS			
P	LTR	DESCRIPTION	DATE	DWN	APVD
B		ECR-06-015596	17JUL06	JMS	FWK

- NOTES:
- ⚠ PACK IN ACCORDANCE WITH AMP SPEC 107-3275
 - ⚠ 100 TRAY PACK IN ACCORDANCE WITH AMP SPEC 107-3275
 - ⚠ Ag PLATING
 - ⚠ THIS ITEM MUST BE WHITE

- 5 ELECTRICAL CHARACTERISTICS
- | | |
|-------------------------------|----------------------------|
| FREQUENCY RANGE: | DC - 4 GHz |
| NOMINAL IMPEDANCE: | 50 Ohm |
| INSULATION RESISTANCE: | 5000 MOhm |
| WORKING VOLTAGE: | 500 Volts RMS at Sea Level |
| DIELECTRIC WITHSTAND VOLTAGE: | 1500 Volts RMS Max |
| CONTACT RESISTANCE: | 1.50 mOhm Max |
| CENTRE CONTACT: | 0.20 mOhm Max |
| OUTER CONTACT: | 1.30:1 Max |
| VSWR @ 4GHz: | 0.20 Max |
| INSERTION LOSS dB @ x 3 GHz: | 0.20 Max |

- 6 MECHANICAL CHARACTERISTICS
- | | |
|-------------------------------|----------------|
| COUPLING NUT RETENTION FORCE: | N/A |
| CABLE RETENTION FORCE: | 170N Min |
| CLAMP NUT RECOMMENDED TORQUE: | 4N |
| MOUNT NUT RECOMMENDED TORQUE: | 4N |
| DURABILITY: | 500 Cycles Min |

- 7 ENVIRONMENTAL CHARACTERISTICS
- | | |
|------------------------|------------------|
| OPERATING TEMPERATURE: | -65 to +165 DegC |
|------------------------|------------------|

8 FOR TECHNICAL DATA REFER TO YOUR LOCAL TYCO ELECTRONICS SALES OFFICE

9 ALL DIMENSIONS ARE NOMINAL FOR REFERENCE ONLY UNLESS OTHERWISE STATED

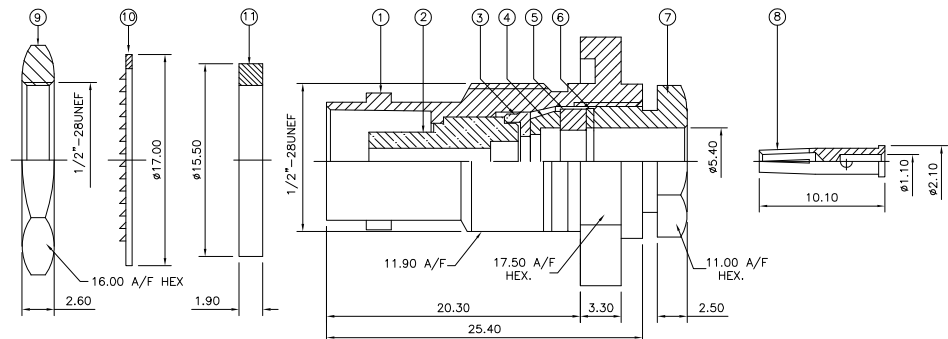

QTY	UNIT	MATERIAL	DESCRIPTION	ITEM
1	1	SILICON RUBBER	GASKET	11
1	1	STEEL	LOCKWASHER	10
1	1	BRASS	HEX. NUT	9
1	1	BRASS	CONTACT	8
1	1	BRASS	CLAMP NUT	7
1	1	BRASS	WASHER	6
1	1	SILICON RUBBER	GASKET	5
1	1	BRASS	SLEEVE	4
1	1	BRASS	WASHER	3
1	1	PTFE	INSULATION	2
1	1	BRASS	BODY	1
6--0	1--0	MATERIAL	DESCRIPTION	ITEM

QTY	UNIT	MATERIAL	DESCRIPTION	ITEM
1	1	SILICON RUBBER	GASKET	11
1	1	STEEL	LOCKWASHER	10
1	1	BRASS	HEX. NUT	9
1	1	BRASS	CONTACT	8
1	1	BRASS	CLAMP NUT	7
1	1	BRASS	WASHER	6
1	1	SILICON RUBBER	GASKET	5
1	1	BRASS	SLEEVE	4
1	1	BRASS	WASHER	3
1	1	PTFE	INSULATION	2
1	1	BRASS	BODY	1

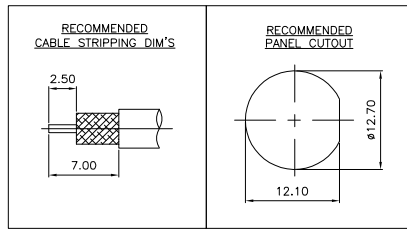

THIS DRAWING IS A CONTROLLED DOCUMENT.		DWN	J. SANDWELL	17JUL06
DIMENSIONS:		CHK	S. PARLOW	17JUL06
mm		APVD	E. WHEELER-KING	17JUL06
TOLERANCES UNLESS OTHERWISE SPECIFIED:		APPLICATION SPEC		
0 PLC	± .05	411-3252		
1 PLC	± .03	WEIGHT		
2 PLC	± .02	MATERIAL		
3 PLC	± .01	SEE TABLE		
4 PLC	± .005	FINISH		
ANGLES	± .05	CUSTOMER DRAWING		

		Tyco Electronics Corporation	
		Bideford EX39 4HE	
NAME		BNC STRAIGHT BULKHEAD JACK MIL-CLAMP 50 OHM	
		RG58C/U, 141A/U, URM43, 76, KX15	
SIZE	CAGE CODE	DRAWING NO	RESTRICTED TO
A3	00779	1478148	
SCALE		SHEET	REV
NTS		1 OF 1	B