

4

3

2

1

THIS DRAWING IS UNPUBLISHED. RELEASED FOR PUBLICATION APRIL, 2004.
 © COPYRIGHT 2004 BY TYCO ELECTRONICS CORPORATION. ALL RIGHTS RESERVED.

LOC		DIST		REVISIONS			
P	LTR	DESCRIPTION		DATE	DWN	APVD	
A		EBD0-0035-03		30JAN04	RS	FWK	

- NOTES:**
- 1 SINGLE PACK IN ACCORDANCE WITH SPEC 107-3275
 - 2 100 TRAY PACK IN ACCORDANCE WITH SPEC 107-3275
 - 3 0.08µm Au PLATING OVER 1.27µm Ni PLATING
 - 4 0.76µm Au PLATING OVER 1.27µm Ni PLATING OVER 0.76µm Cu PLATING
- 5 FOR TECHNICAL DATA REFER TO YOUR LOCAL TYCO ELECTRONICS SALES OFFICE
- 6 ALL DIMENSIONS ARE NOMINAL FOR REFERENCE ONLY UNLESS OTHERWISE STATED

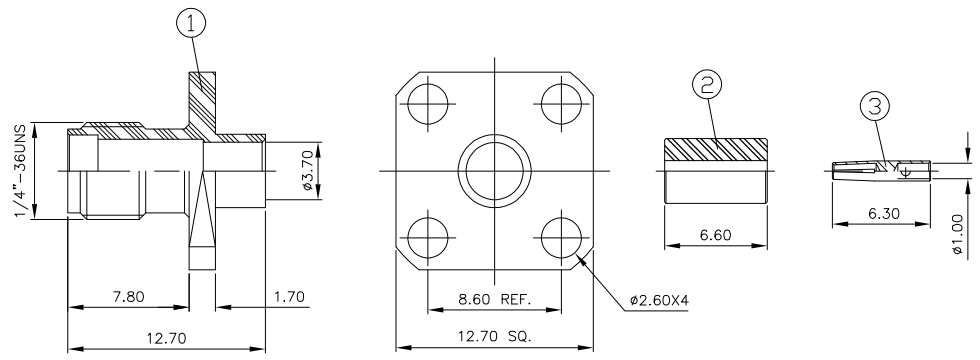

RECOMMENDED CABLE STRIPPING DIM'S

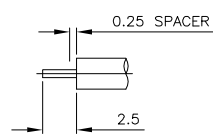

QUANTITY PER ASSY				PARTS LIST		
		1	1	PTFE	INSULATOR	3
		1	1	BERYLLIUM COPPER	SOCKET	2
		1	1	STAINLESS STEEL	BODY	1
		1--1	1--0	MATERIAL	DESCRIPTION	ITEM

THIS DRAWING IS A CONTROLLED DOCUMENT.		DWN R.SMITH 30JAN04	Tyco Electronics Corporation	
		CHK S.PARLOW 30JAN04	Bideford, UK, EX39 4HE	
DIMENSIONS: mm		APVD F.WHEELER-KING 30JAN04	NAME SMA PANEL JACK 4 HOLE FLANGE DIRECT SOLDER NON CAPTIVE CONTACT RG402/U	
TOLERANCES UNLESS OTHERWISE SPECIFIED:		PRODUCT SPEC 108-3460	SIZE CAGE CODE DRAWING NO RESTRICTED TO	
0 PLC ± -		APPLICATION SPEC 411-3276	A3 00779 C-1478930	
1 PLC ± -		WEIGHT -	CUSTOMER DRAWING	
2 PLC ± -		SCALE 1:1 SHEET 1 OF 1 REV A		
3 PLC ± -				
4 PLC ± -				
ANGLES ± -				
MATERIAL SEE TABLE				
FINISH -				