

4

3

2

1

THIS DRAWING IS UNPUBLISHED. RELEASED FOR PUBLICATION.
 © COPYRIGHT BY TYCO ELECTRONICS CORPORATION. ALL RIGHTS RESERVED.

LOC	DIST	REVISIONS					
		F	LTR	DESCRIPTION	DATE	BY	APPD
AJ	16	A		REVISED PER OS14-0192-05	16FEB2006	KS	JGH

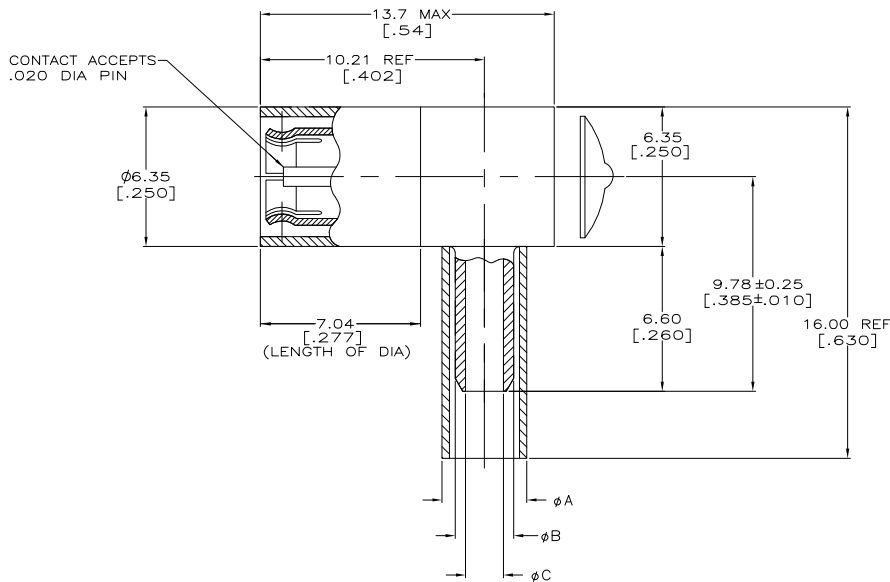

- △ MATERIALS:
 BODY: ZINC PER ASTM B 86.
 CENTER CONTACT: BERYLLIUM COPPER PER ASTM B 194.
 OUTER CONTACT: BERYLLIUM COPPER PER ASTM B 194.
 DIELECTRIC: TEFLON PER ASTM D 1710.
- △ FINISHES:
 BODY: NICKEL PER QQ-N-290.
 CENTER CONTACT: GOLD PER ASTM B 488.
 OUTER CONTACT: NICKEL PER QQ-N-290.
- △ FINISHES:
 BODY: NICKEL PER QQ-N-290.
 CENTER CONTACT: GOLD PER ASTM B 488.
 OUTER CONTACT: GOLD PER ASTM B 488.
- 4. DO NOT MATE WITH MIL-C-39012 CONNECTORS.
- △ TOOLING INFORMATION:
 BRAID CRIMP: HAND TOOL M-22520/5-01 WITH DANIELS
 DIE SET # HX4-1637 OR AMP PRO-CRIMPER WITH DIE
 SET # 58483-1 (.128 HEX).
 CENTER CONTACT: SOLDERED.
- △ FOR USE WITH RG-179/U CABLE.
- 7. SEE INSTRUCTION SHEET 408-2987-9.
- △ FOR USE WITH RG-179 DOUBLE-BRAIDED CABLE

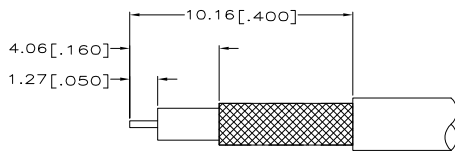

RECOMMENDED STRIP LENGTH

1.73 [.068]	2.64 [.104]	4.55 [.179]	△	△	△	5415484-3
1.73 [.068]	2.64 [.104]	3.86 [.152]	△	△	△	5415484-2
1.73 [.068]	2.64 [.104]	3.86 [.152]	△	△	△	5415484-1
φC ±0.08 [.003]	φB ±0.05 [.002]	φA ±0.05 [.002]	CABLE	TOOLING	FINISH	PART NUMBER

THIS DRAWING IS A CONTROLLED DOCUMENT.		BY J. HAVENER 31MAR2005	DATE 31MAR2005	BY J. HAVENER 31MAR2005	DATE 31MAR2005	NAME Tyco Electronics Corporation Harrisburg, Pa 17105-3608
DIMENSIONS: mm [INCHES]	TO MANUFACTURE TO THESE DIMENSIONS, USE THE FOLLOWING TOLERANCES UNLESS SPECIFIED:	APPROVED J. HAVENER 31MAR2005	PRODUCT SPEC	APPLICATION SPEC	SIZE A2	CAGE CODE 00779
MATERIAL △	FINISH △ △	WEIGHT	RESTRICTED TO	CUSTOMER DRAWING	SCALE 8:1	SHEET 1 of 1
DRAWING NO C-5415484						REV A

AMP 1471-9 REV 31MAR2005

5415484

A