

DRAWING MADE IN THIRD ANGLE PROJECTION

THIS DRAWING IS UNPUBLISHED. RELEASED FOR PUBLICATION, 19 .

© COPYRIGHT 19 BY AMP INCORPORATED. ALL INTERNATIONAL RIGHTS RESERVED.

LOC	DIST	P	F	ZONE	LTR	REVISIONS	DATE	APPD
AJ	16					REDWN PER 0220-0412-94	6-3-94	JL

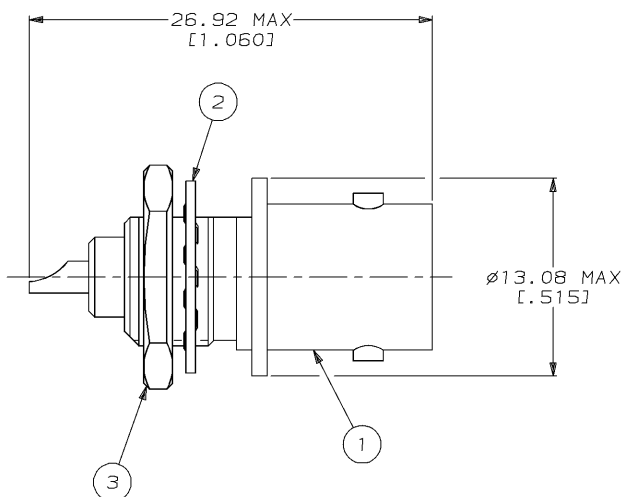

1. .125 MAX PANEL THICKNESS.

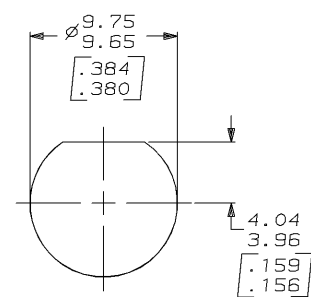

RECOMMENDED PANEL CUTOUT

SUPERSEDED BY 227715-3	1-330249-1	1-329492-1	227717-3	227715-3
SUPERSEDED BY 227715-3	1-330249-1	1-329492-1	227717-2	227715-2
	1-330249-1	1-329492-1	227717-1	227715-1
(3) JAM NUT QTY=1	(2) LOCKWASHER QTY=1	(1) JACK ASSY QTY=1	PART NUMBER	

			PART NO		
DO NOT SCALE PRINT. UNLESS SPECIFIED DIMENSIONS IN mm [INCHES] TOLERANCES ON: 2 PLC DEC ± - 3 PLC DEC ± - ANGLES ± -	DR 6-3-94 J. LIPPERT	AMP Incorporated Harrisburg, PA 17105-3608	NAME SOLDER JACK, 50Ω, SERIES BNC		
MATERIAL -	CHK 6-3-94 M. TOMCHAK		SIZE B	CAGE CODE 00779	DRAWING NO 227715
FINISH -	APPD 6-3-94 M. TOMCHAK		SCALE 4:1	SHEET 1 OF 1	
	APPD 6-3-94 J. LIPPERT		PRODUCT SPEC 108-12079		
	APPLICATION SPEC -	WEIGHT -			

AMP 1470-15 REV 11-89
06 JUN 1994 16:19:38 AMP25904

CUSTOMER DRAWING