

4

3

2

1

THIS DRAWING IS UNPUBLISHED. RELEASED FOR PUBLICATION
 © COPYRIGHT BY TYCO ELECTRONICS CORPORATION. ALL RIGHTS RESERVED.

LOC	DIST	REVISIONS			
F	LTR	DESCRIPTION	DATE	BY	APP'D
	T2	REV PER ECO 06-029805	2/6/2007	DW	JL

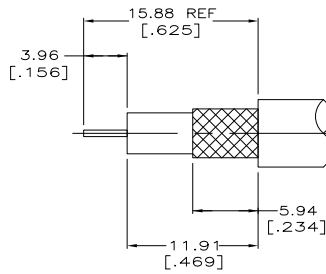
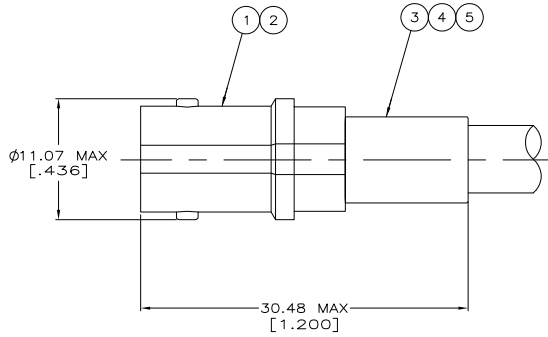

RECOMMENDED STRIP LENGTH

- ⚠ USE CRIMP TOOL: 220190-1 OR PRO-CRIMPER
- 2. USE INSTRUCTION SHEET 408-9090
- 3. DIELECTRIC MUST WITHSHAND A 5 LB PUSH OUT FORCE
- ⚠ SPECIAL PACKAGING
- ⚠ SUPERSEDED BY 221199-2
- ⚠ CUSTOM CABLE:
CENTER CONDUCTOR = ϕ .016
DIELECTRIC = ϕ .070
JACKET = ϕ .110
- ⚠ CUSTOM CABLE:
CENTER CONDUCTOR = ϕ .016
DIELECTRIC = ϕ .075
JACKET = ϕ .120

OBSOLETE	RG-59/U,59A/U & 59B/U	58085-1	-	-	9-50428-0	221200-3	221202-2	9-221199-1
OBSOLETE	BELDEN 9248, MADISON 18AWG	58086-1	-	-	9-50427-0	3-221200-2	221202-1	9-221199-0
OBSOLETE	C&M CABLE 25785	58304-4	-	-	3-328666-6	221200-6	221202-4	221199-9
⚠ OBSOLETE	CUSTOM CABLE	58304-5	1-222001-6	414932-3	3-328666-9	221200-9	221202-3	221199-8
⚠ OBSOLETE	CUSTOM CABLE	58304-1	222001-8	227194-2	9-328666-0	221200-9	221202-3	221199-7
OBSOLETE	AT&T 735A	58174-1	-	-	9-328666-2	221200-9	221202-3	221199-6
	RG-179	58304-1	222001-8	227194-2	9-328666-0	2-221200-0	221202-3	221199-5
⚠ OBSOLETE	RG-59/U,59A/U & 59B/U	58085-1	-	-	9-50428-0	221200-3	221202-2	221199-4
SUPERSEDED BY 413760-3	BELDEN 8218	58174-1	-	-	9-329461-0	221200-9	221202-3	221199-3
OBSOLETE	RG-59/U,59A/U & 59B/U	58085-1	-	-	9-50428-0	221200-3	221202-2	221199-2
	BELDEN 9248, MADISON 18AWG	58086-1	-	-	9-50427-0	3-221200-2	221202-1	221199-1
	FOR USE WITH CABLE	DIE SET	⚠ (5) TUBING, METAL QTY=1	(4) TUBING, PLASTIC QTY=1	(3) FERRULE QTY=1	(2) CONTACT QTY=1	(1) JACK ASSEMBLY QTY=1	PART NUMBER

THIS DRAWING IS A CONTROLLED DOCUMENT.

DIMENSIONS: mm [INCHES]	TO DIMENSIONS UNLESS OTHERWISE SPECIFIED.	DRN: S. SCOTT 1-15-91	BY: J. LIPPERT 1-20-91	CHK: M. PHILLIPS 1-20-91	NAME: M. PHILLIPS	TYCO Electronics Tyco Electronics Corporation Harrisburg, PA 17105-3608
		APPLICATION SPEC: 108-12095	SIZE: A2	CAGE CODE: 00779	DRAWING NO: C=221199	RESTRICTED TO: -
MATERIAL: -	FINISH: -	WEIGHT: -	CUSTOMER DRAWING		SCALE: 4:1	SHEET: 1 of 1 REV: T2

AMP 1471-9 REV 31MM2000

221199

A