

4

3

2

1

THIS DRAWING IS UNPUBLISHED. RELEASED FOR PUBLICATION NOV. 2005.
 © COPYRIGHT 2005 BY TYCO ELECTRONICS CORPORATION. ALL RIGHTS RESERVED.

LOC	DIST	REVISIONS			
P	LTR	DESCRIPTION	DATE	DWN	APVD
C		ECR-05-015880	18NOV05	JMS	FWK

- NOTES:**
- ⚠ PACK IN ACCORDANCE WITH AMP SPEC 107-3275
 - ⚠ 100 TRAY PACK IN ACCORDANCE WITH AMP SPEC 107-3275
 - ⚠ Ag PLATING
 - ⚠ THIS ITEM MUST BE WHITE
- 5 ELECTRICAL CHARACTERISTICS**
- | | |
|-------------------------------|----------------------------|
| FREQUENCY RANGE: | DC - 4 GHz |
| NOMINAL IMPEDANCE: | 50 Ohm |
| INSULATION RESISTANCE: | 5000 MOhm |
| WORKING VOLTAGE: | 500 Volts RMS at Sea Level |
| DIELECTRIC WITHSTAND VOLTAGE: | 1500 Volts RMS Max |
| CONTACT RESISTANCE: | 1.50 mOhm Max |
| CENTRE CONTACT: | 0.20 mOhm Max |
| OUTER CONTACT: | 1.30:1 Max |
| VSWR @ 4GHz: | 0.20 Max |
| INSERTION LOSS dB @ x 3 GHz: | |
- 6 MECHANICAL CHARACTERISTICS**
- | | |
|-------------------------------|----------------|
| COUPLING NUT RETENTION FORCE: | 445N Min |
| CABLE RETENTION FORCE: | 170N Min |
| CLAMP NUT RECOMMENDED TORQUE: | 4N |
| DURABILITY: | 500 Cycles Min |
- 7 ENVIRONMENTAL CHARACTERISTICS**
- | | |
|------------------------|------------------|
| OPERATING TEMPERATURE: | -65 to +165 DegC |
|------------------------|------------------|

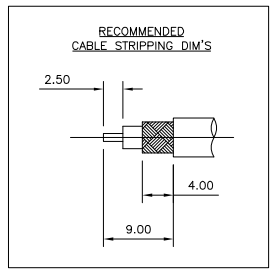
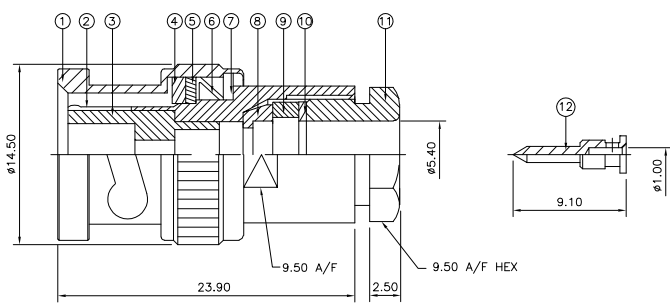

QTY	UNIT	MATERIAL	DESCRIPTION	ITEM
1	1	BRASS	CONTACT	12
1	1	BRASS	CLAMP NUT	11
1	1	BRASS	WASHER	10
1	1	SILICON RUBBER	GASKET	9
1	1	BRASS	SLEEVE	8
1	1	BRASS	WASHER	7
1	1	SPRING STEEL	SPRING	6
1	1	BRASS	WASHER	5
1	1	SILICON RUBBER	GASKET	4
1	1	PTFE	INSULATION	3
1	1	BRASS	BODY	2
1	1	BRASS	SHELL	1
6--0	1--0	MATERIAL	DESCRIPTION	ITEM

THIS DRAWING IS A CONTROLLED DOCUMENT.

DIMENSIONS: mm	TOLERANCES UNLESS OTHERWISE SPECIFIED:	DWN J. SANDWELL 18NOV05	18NOV05	Tyco Electronics Corporation	Tyco Electronics Corporation
	0 PLC ± -	CHK S. PARLOW 18NOV05		Electronics	Bideford EX39 4HE
	1 PLC ± -	APVD F. WHEELER-KING 18NOV05		NAME	BNC STRAIGHT PLUG SOLDER 50 OHM
	2 PLC ± -	PRODUCT SPEC	108-3435		RG58C/U, 141A/U, URM43,76, Belden 9907,KX15
	3 PLC ± -	APPLICATION SPEC	411-3252		RESTRICTED TO
4 PLC ± -	ANGLES ± -	WEIGHT	-	SIZE	A3
MATERIAL	FINISH	CUSTOMER DRAWING		CAGE CODE	00779
SEE TABLE				DRAWING NO	1337421
				SCALE	NTS
				SHEET	1 OF 1
				REV	C