

THIS DRAWING IS UNPUBLISHED. RELEASED FOR PUBLICATION
 © COPYRIGHT - BY TYCO ELECTRONICS CORPORATION. ALL RIGHTS RESERVED.

LOC	DIST	REVISIONS					
AJ	16	P	LTR	DESCRIPTION	DATE	DWN	APVD
		Z		REV PER ECO 08-009474	7/18/2008	DW	JL

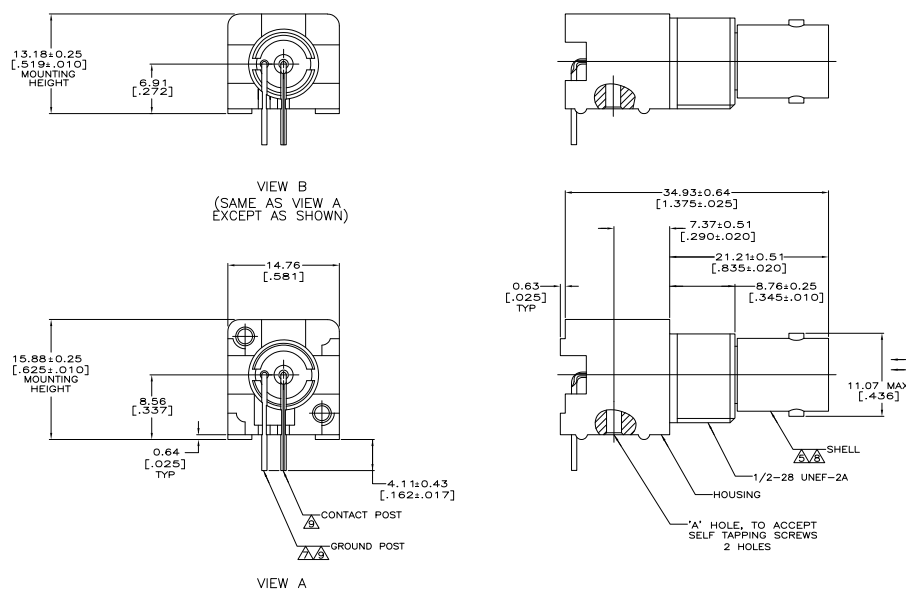

- △ POLYESTER PBT PER MIL-M-24519, TYPE GPT-15F, UL94V-0 RATED, COLOR:NATURAL
 - △ POLYESTER PBT PER MIL-M-24519, TYPE GPT-15F, UL94V-0 RATED, COLOR:BLACK
 - △ POLYESTER PBT PER MIL-M-24519, TYPE GPT-15F, UL94V-0 RATED, COLOR:BLUE
 - △ POLYMETHYLPENTENE, GENERAL PURPOSE.
 - △ ZINC PER QQ-Z-363.
 - △ PHOSPHOR BRONZE PER QQ-B-750.
 - △ BRASS PER ASTM-B-453.
 - △ NICKEL PLATE PER QQ-N-290, 3.81 μm [.000150] MINIMUM THICK.
 - △ TIN PLATE PER ASTM-B-545, 3.81 μm [.000150] MINIMUM THICK.
 - △ GOLD PLATE PER MIL-G-45204, 0.76 μm [.000030] MINIMUM THICK.
 - △ SILVER PLATE PER QQ-S-365, 2.54 μm [.000100] MINIMUM THICK.
12. SEE INSTRUCTION SHEET 2769.

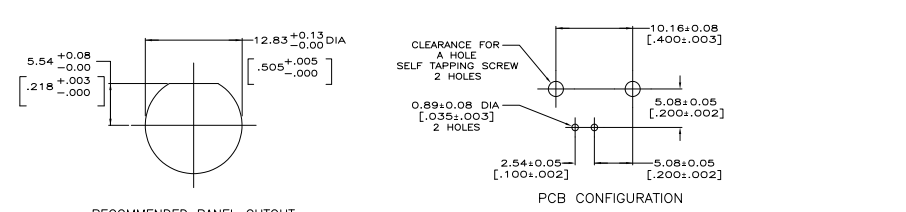

SUPERSEDED BY 226990-7	B	M2.6	△	△	△	226990-8
OBSOLETE	B	#2-56	△	△	△	226990-7
SUPERSEDED BY 226990-3	A	#2-56	△	△	△	226990-6
SUPERSEDED BY 226990-6	A	#2-56	△	△	△	226990-5
	A	#2-56	△	△	△	226990-4
	A	#2-56	△	△	△	226990-3
	A	#2-56	△	△	△	226990-2
OBSOLETE	A	#2-56	△	△	△	226990-1
	A	#2-56	△	△	△	
VIEW	HOLE	CONTACT PLATING	HOUSING MATERIAL	PART NUMBER		

THIS DRAWING IS A CONTROLLED DOCUMENT.

DIMENSIONS: mm [INCHES]	TOLERANCES UNLESS OTHERWISE SPECIFIED:	DWN B. SCOTT 04-30-91	Tyco Electronics Corporation Harrisburg, Pa 17105-3608	
0 PLC ± -	1 PLC ± -	CHK J. LIPPERT 08-06-91	NAME JACK, PANEL, RIGHT ANGLE, 50 OHM, PCB, SERIES BNC	
2 PLC ± 0.20 [.008]	3 PLC ± -	APVD A. GABANY 08-06-91	PRODUCT SPEC 108-12078	
4 PLC ± -	ANGLES ± -		APPLICATION SPEC	
MATERIAL 1 THRU 7	FINISH 8 THRU 11	WEIGHT -	SIZE A3	CAGE CODE 00779
		DRAWING NO C-226990		RESTRICTED TO -
CUSTOMER DRAWING			SCALE 4:1	SHEET 1 OF 1