

- NOTES:
- MATERIALS AND FINISHES:
 OUTER CONTACT - PHOSPHOR BRONZE, NICKEL PLATING (.0001 THICK)
 FRONT BODY - ZINC ALLOY, NICKEL PLATING (.00015 THICK)
 CRIMP CONTACT - BRASS, GOLD PLATING (.00005 THICK)
 INSULATOR - PTFE
 - ELECTRICAL:
 A. IMPEDANCE: 75 OHM
 B. FREQUENCY RANGE: DC - 3 GHz
 C. VSWR/RETURN LOSS: 1.10 UP TO 2 GHz (-26.44 dB), 1.16 UP TO 3 GHz (-22.61 dB)
 D. DIELECTRIC WITHSTANDING VOLTAGE: 1500 VRMS, MIN.
 E. WORKING VOLTAGE: 500 VAC PEAK
 - MECHANICAL:
 A. DURABILITY: 500 CYCLES MIN.
 B. TEMPERATURE RANGE: -40° C TO +85° C
 - PACKAGING:
 A. QUANTITY: SINGLE PACK
 B. MARKING: BAG TO BE MARKED "AMPHENOL 611X-4217, AND DATE CODE"
 - FOR CABLE STRIPPING AND ASSEMBLY INSTRUCTIONS SEE AMPHENOL SPEC 349-50756.
 FERRULE TO BE CRIMPED WITH A .255 HEX DIE.
 CONTACT TO BE CRIMPED WITH A .042 SQUARE DIE
 OR A 8 PT CRIMPER AMPHENOL NUMBER CTL-T1200

31-80404		REVISIONS			
DRAWING NO.	REV	DESCRIPTION	DATE	ECO	APPR
THIRD ANGLE PROJ.	A	RELEASE TO MFG.	8/17/06	46206	GSA
	B	NOTE 5 '8 PT CRIMPER AMPHENOL NUMBER CTL-T1200'	8/6/07	46681	TC

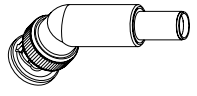

SCALE 1.000

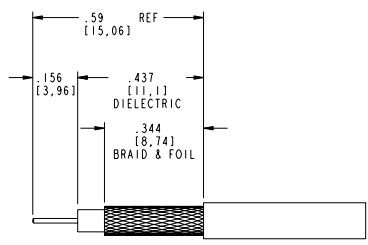
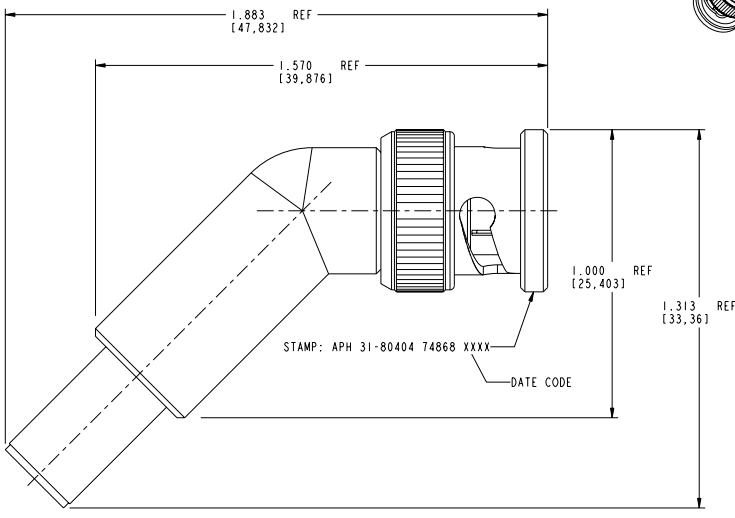

RECOMMENDED CABLE STRIPPING DIMENSIONS
SCALE 3.000

CUSTOMER OUTLINE DRAWING
ALL OTHER SHEETS ARE FOR INTERNAL USE ONLY

UNLESS OTHERWISE SPECIFIED, DIMENSIONS ARE IN INCHES AND TOLERANCES ARE: 2 PLACE DECIMAL ±.015 (0.381 mm) 3 PLACE DECIMAL ±.005 (0.127 mm) ANGLES ± 1°	MATERIAL	DRAWN G. ANTONINI	DATE 28-Mar-05	TITLE	Amphenol RF Danbury, CT, USA Tainan, Taiwan Shenzhen, China www.amphenolrf.com
	REFERENCE	ENGINEER G. ANTONINI	DATE 28-Mar-05	BNC 45° ANGLE PLUG FOR AT&T 734 CABLE	
NOTICE - These drawings, specifications, or other data (1) are, and remain the property of Amphenol Corp. (2) must be returned upon request; and (3) are confidential and not to be disclosed to any person other than those to whom they are given by Amphenol Corp. The furnishing of these drawings, specifications, or other data by Amphenol Corp., or to any other person for any purpose is not to be regarded by implication or otherwise in any manner licensing, granting rights or permitting such holder or any other person to manufacture, use or sell any product, process or design, patented or otherwise, that may in any way be related to or disclosed by said drawings, specifications, or other data.		APPROVED O. BARTHELME	DATE 8/17/06	SCALE: 3.0:1	SHEET 2 OF 2
		CAD FILE 31-80404	CODE ID 74868	DWG SIZE B	DRAWING NO. 31-80404