

REV.	DATE	DESCRIPTION
A	06/16/01	MODIFY PLATING SPEC
B	01/30/04	UPDATE DRAWING FORMAT/MODIFY BODY LENGTH/COVER

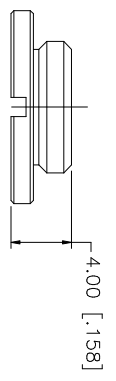
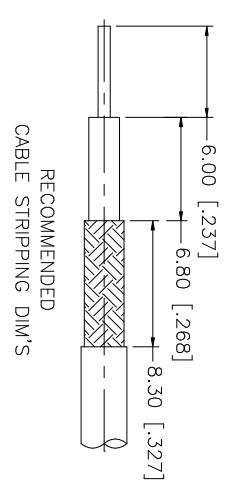
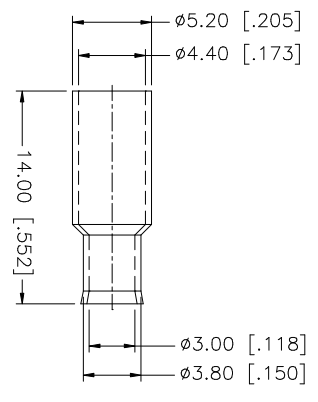
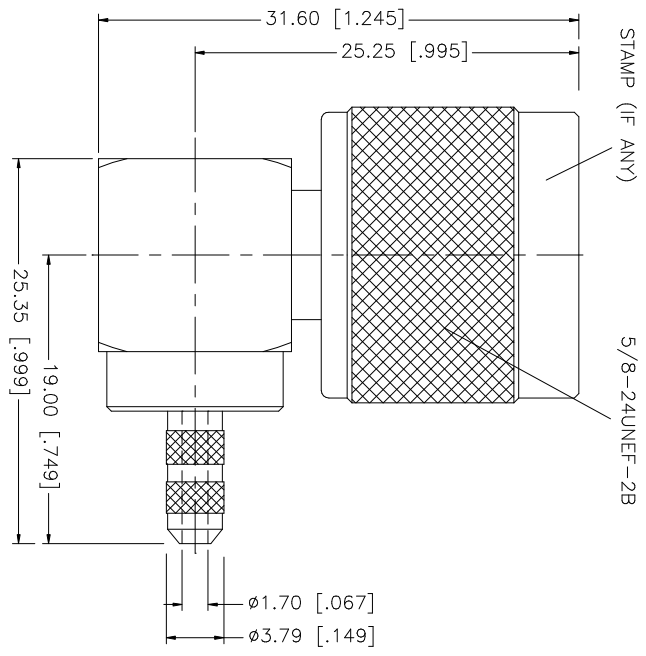

NOTE:
 1. CRIMPED FERRULE
 HEX. CRIMP SIZE .178"
 2. CONTACT PIN TO SOLDER.

QTY	FINISH	MATERIAL	DESCRIPTION
1	NEXCOTE	BRASS	INSULATOR BODY
1	NATURAL	TEFLON	INSULATOR
1	GOLD	BRASS	CONTACT PIN
1	NEXCOTE	BRASS	FERRULE
1	NEXCOTE	BRASS	CLAMP NUT

APPROVALS	DATE
DRAWN G.R.S.	01/30/04
CHECKED	
ISSUED	
SHEET 1 OF 1	

PART NO.	DWG. NO.	REV.	SIZE	SCALE
1722180	1722180.DWG	B	A	NA

DO NOT SCALE DRAWING	UNLESS OTHERWISE SPECIFIED DIMENSIONS ARE IN MILLIMETERS DIMENSIONS IN [] ARE IN INCHES AND FOR CUSTOMER REFERENCE ONLY.
UNLESS OTHERWISE SPECIFIED TOLERANCES FOR MILLIMETERS ARE: 0.5 - 8mm ± 0.20mm 8 - 30mm ± 0.40mm 30 - 120mm ± 0.50mm	UNLESS OTHERWISE SPECIFIED TOLERANCES FOR INCHES ARE: .020 - .315 = ± 0.007" .315 - 1.180 = ± 0.015" 1.180 - 4.724 = ± 0.020"

CAD FILE	APPROVALS	DATE
C:/172/172180.DWG	G.R.S.	01/30/04

Amphenol Connex

PART DESCRIPTION
 N R/A CRIMP PLUG
 (FOR RG-174/U, 188/U, 316/U CABLE)