

REV.	DATE	DESCRIPTION
A	11/21/02	UPDATE END CAP / REFORMAT DRAWING
B	03/06/03	UPDATE DRAWING FORMAT

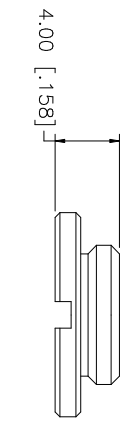
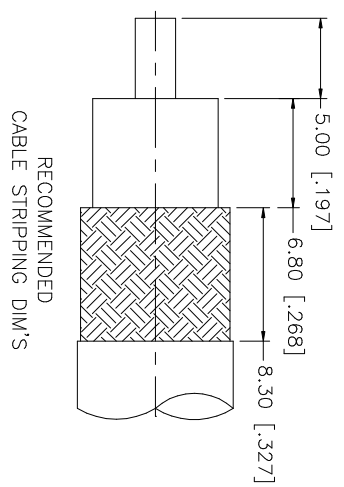
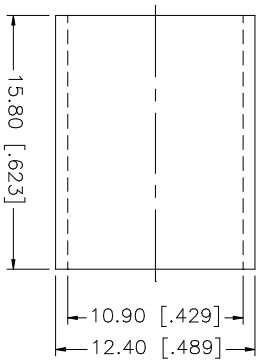
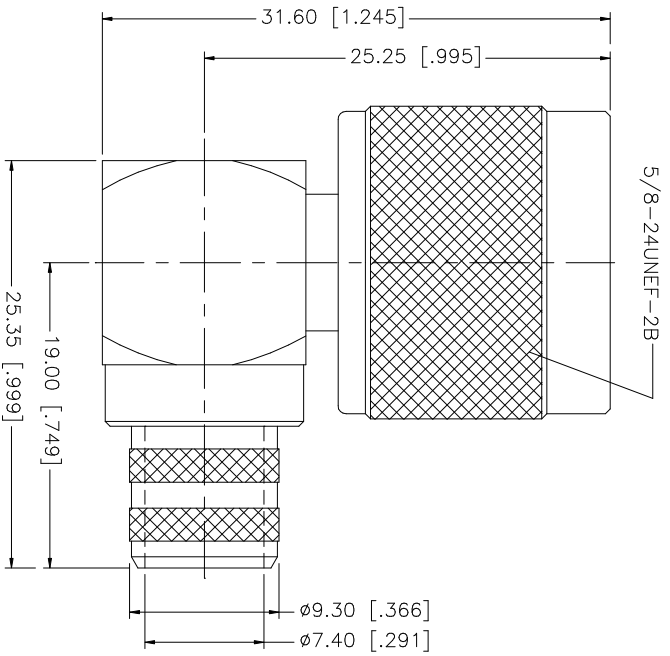

CRIMP NOTES:

1. CRIMPED FERRULE
HEX CRIMP SIZE .429"
2. CONTACT PIN TO SOLDER

QTY	FINISH	MATERIAL	DESCRIPTION
1	NEXCOTE	COPPER	FERRULE
1	NEXCOTE	BRASS	CLAMP NUT
1	NATURAL	SUS 304	RETAINER RING
1	RED	SILICONE	GASKET
1	GOLD	BER. COPPER	CONTACT PIN
1	NATURAL	TEFLON	INSULATOR
1	NEXCOTE	BRASS	SHELL
1	NEXCOTE	BRASS	BODY/BARREL

APPROVALS	DATE
DRAWN G.R.S.	03/06/03
CHECKED	
ISSUED	
SHEET 1 OF 1	

DO NOT SCALE DRAWING	UNLESS OTHERWISE SPECIFIED DIMENSIONS ARE IN MILLIMETERS. DIMENSIONS IN [] ARE IN INCHES AND FOR CUSTOMER REFERENCE ONLY. TOLERANCES FOR MILLIMETERS ARE:	UNLESS OTHERWISE SPECIFIED DIMENSIONS ARE IN MILLIMETERS. DIMENSIONS IN [] ARE IN INCHES AND FOR CUSTOMER REFERENCE ONLY. TOLERANCES FOR INCHES ARE:
	0.5 - 8mm ± 0.20mm 8 - 30mm ± 0.40mm 30 - 120mm ± 0.50mm	.020 - .315 = ± 0.007" .315 - 1.180 = ± 0.015" 1.180 - 4.724 = ± 0.020"

CAD FILE	DWG. NO.	REV.	NC	SIZE	SCALE
C:/172/172176.DWG	172176.DWG			A	NA

PART NO.	DESCRIPTION
172176	N R/A CRIMP PLUG (FOR RG-8/U, 213/U, 393/U CABLE)

Amphenol Connex