

13 12 11 10 9 8 7 6 5 4 3 2 1

MATERIALS AND FINISHES

- BODY ZINC ALLOY
PLATED NICKEL
- CENTER CONTACT PHOSPHOR BRONZE
PLATED GOLD
- INSULATOR POLYPROPYLENE (94 V-2)

HOUSING POLYESTER BUTLYENE TEREPHTHALATE
COLOR WHITE

MOUNTING POST BRASS
PLATED TIN

SOLDER TAIL BRASS WIRE
PLATED TIN

LOCKWASHER PHOSPHOR BRONZE
PLATED NICKEL

JAM NUT BRASS
PLATED NICKEL

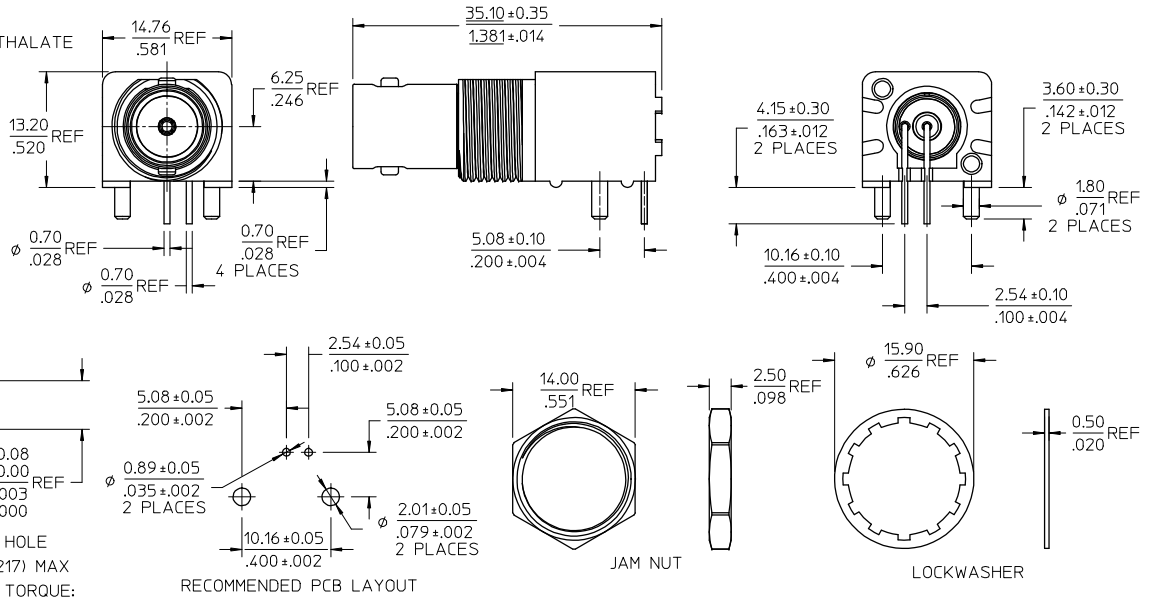
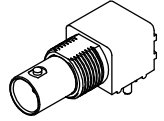
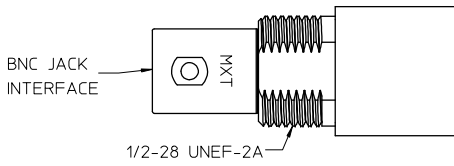

PS-73598-0051	PRODUCT SPECIFICATION
ES-73599-0000	INTERFACE
SPECIFICATION	DESCRIPTION

73171-2990	73100-0069, ONE PER BAG
73100-0069	PLASTIC TRAYS
PART NO.	PACKAGING

CHG: REDREW IN SD ADDED P/N 73171-2990	EC NO: UPE2007-0396 DRAWN: TELAHERY 2007/05/01 CHKD: SSMAR 2007/05/01 APPR: JWIENER 2007/05/01	QUALITY SYMBOLS ▽=0 ▽=0	GENERAL TOLERANCES (UNLESS SPECIFIED)		DIMENSION STYLE MM/IN		SCALE	DESIGN UNITS METRIC	THIRD ANGLE PROJECTION
			4 PLACES ±--- ±---	3 PLACES ±--- ±---	2 PLACES ±--- ±---	1 PLACE ±--- ±---	ANGULAR ± 2 °	DRAWN BY DATE	CHECKED BY DATE
DRAFT WHERE APPLICABLE MUST REMAIN WITHIN DIMENSIONS			MATERIAL NO. SEE TABLE		DOCUMENT NO. SD-73100-0069		SHEET NO. 1 OF 1		MOLEX INCORPORATED
THIS DRAWING CONTAINS INFORMATION THAT IS PROPRIETARY TO MOLEX INCORPORATED AND SHOULD NOT BE USED WITHOUT WRITTEN PERMISSION									

12 11 10 9 8 7 6 5 4 3 2 1