

REV.	DATE	DESCRIPTION
A	04/05/03	UPDATE DRAWING FORMAT
B	07/19/07	REVISE BARREL AND FERRULE DIMENSIONS

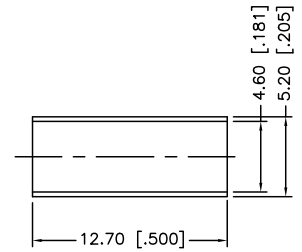
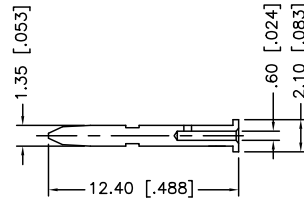
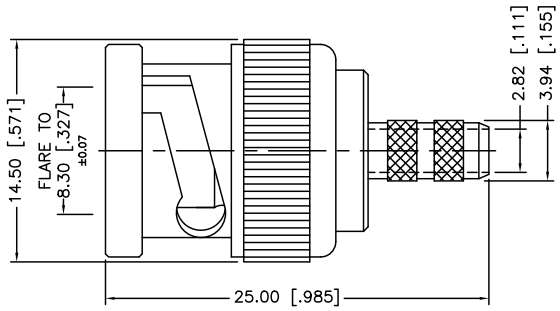
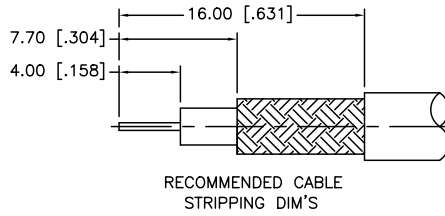

DESCRIPTION	MATERIAL	FINISH	QTY	UNLESS OTHERWISE SPECIFIED DIMENSIONS ARE IN MILLIMETERS. DIMENSIONS IN [] ARE IN INCHES AND FOR CUSTOMER REFERENCE ONLY.	APPROVALS	DATE	Amphenol Connex					
8					DRAWN	G.R.S.	07/19/07	PART DESCRIPTION BNC CRIMP PLUG (BELDEN 8218/VFM 809/1407B/1167B-75ohms)				
7					CHECKED							
6					ISSUED							
5	FERRULE	BRASS	NICKEL	1	SHEET	1 OF 1					PART NO. 112955	
4	GASKET	RUBBER	RED	1	CAD FILE C:/112/112955.DWG			DWG. NO.	112955.DWG	REV. B	SIZE A	SCALE NA
3	INSULATOR	TEFLON	NATURAL	1	UNLESS OTHERWISE SPECIFIED TOLERANCES FOR MILLIMETERS ARE: 0.5 - 8mm ± 0.20mm 8 - 30mm ± 0.40mm 30 - 120mm ± 0.50mm							
2	CONTACT PIN	BRASS	GOLD	1	UNLESS OTHERWISE SPECIFIED TOLERANCES FOR INCHES ARE: .020 - .315 = ± 0.007" .315 - 1.180 = ± 0.015" 1.180 - 4.724 = ± 0.020"							
1	SHELL/BODY	BRASS	NICKEL	1	DO NOT SCALE DRAWING							