

DRAWING MADE IN THIRD ANGLE PROJECTION

THIS DRAWING IS UNPUBLISHED. RELEASED FOR PUBLICATION, 19
 © COPYRIGHT 19 BY AMP INCORPORATED. ALL INTERNATIONAL RIGHTS RESERVED.

LOC	DIST	REVISIONS				
P	F	ZONE	LTR	DESCRIPTION	DATE	APPD
AJ	16			REV PER 0630-0431-98	280CT98	MO

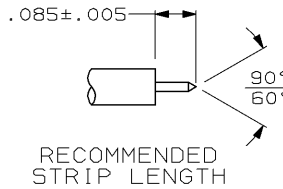
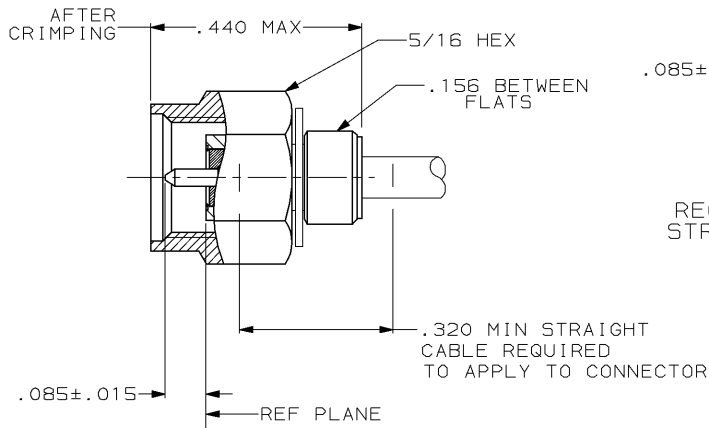

1. FOR USE WITH: RG-405/U, .086 SEMI RIGID CABLE
2. PNEUMATIC TOOL: 59964-1
CRIMPING TOOL: 59980-1
3. SEE I.S. 2924
4. STAINLESS STEEL PER ASTM-A-582
5. BERYLLIUM COPPER PER ASTM-B-197
6. SILICONE RUBBER PER ZZ-R-765
7. PTFE PER ASTM D1710
8. BRASS PER ASTM-B-36
9. GOLD PER MIL-G-45204
10. PASSIVATION PER ASTM A967
11. NICKEL PL PER QQ-N-290
12. PRODUCT IS DESIGNED TO MEET PRODUCT SPECIFICATION 108-12055
13. AF8627286-2 AMP

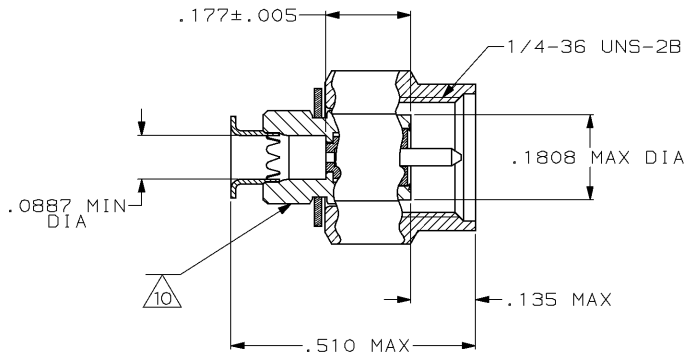

221447-1

PART NO

DO NOT SCALE PRINT. UNLESS SPECIFIED DIMENSIONS IN INCHES TOLERANCES ON: 2 PLC DEC ± 3 PLC DEC ± ANGLES ±	DR C. BAKER	2-15-89	AMP AMP INCORPORATED Harrisburg, Pa. 17105
	CHK L. MOSCOSO	4-10-88	
MATERIAL 4 THRU 8	APPD P. HENRY	4-10-88	NAME CONNECTOR, COAXIAL, RF, PLUG, SERIES SMA
FINISH 9 THRU 11	APPD L. MOSCOSO	4-10-88	PRODUCT SPEC
	APPLICATION SPEC		SIZE B
	WEIGHT		FSCM NO 00779
			DRAWING NO 221447-1
			SCALE 5:1
			SHEET 1 OF 1

CUSTOMER DRAWING

AMP 1470-15 REV 3-87

28-OCT-98 15:08:37 amp06572 /home/amp06572/edmod