

Description	Material	Finish
Body	Brass	Nickel
Socket	BE CU	Gold
Insulation	Teflon	Teflon

REVISIONS			
REV	DESCRIPTION	DATE	APPV
A	New Frame; correct one dimension	10/4/10	CJ
B	Revise footprint drawing	11/23/10	CJ

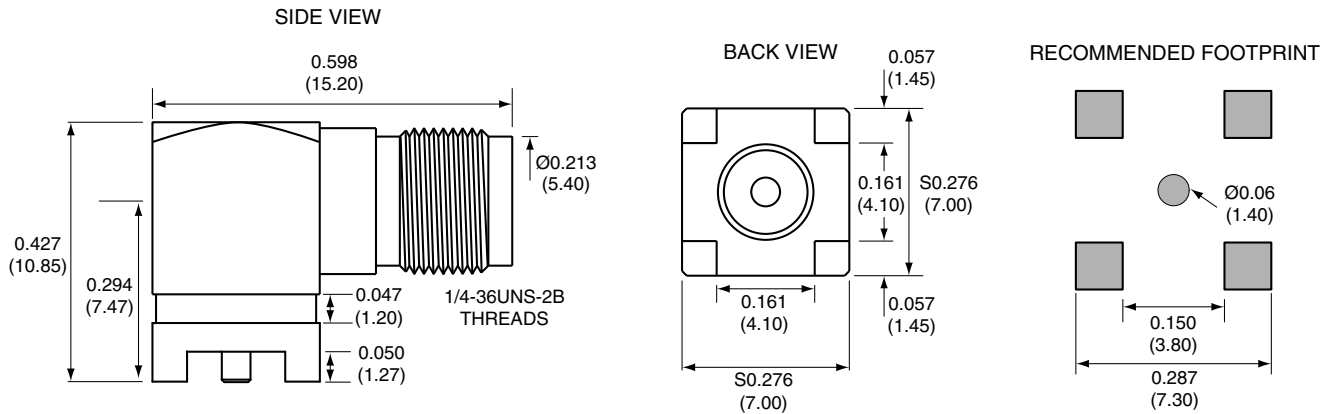

NOTES: (UNLESS OTHERWISE SPECIFIED)

1. ALL DIMENSIONS ARE IN INCHES [mm].
2. DIMENSIONS APPLY AFTER FINISHING.
3. MANUFACTURE TO BE COMPLIANT WITH EU RoHS DIRECTIVE.
4. SAFETY BREAK ALL SHARP CORNERS AND EDGES .02 MAXIMUM.

WARNING: THIS DRAWING CONTAINS PROPRIETARY INFORMATION THAT IS THE SOLE PROPERTY OF CONNECTOR CITY, AND SHALL BE TREATED AS SUCH. NO DISCLOSURE OR REPRODUCTION OF THIS DOCUMENT IS PERMITTED, IN WHOLE OR IN PART, WITHOUT THE EXPRESS WRITTEN PERMISSION OF CONNECTOR CITY OR ITS DESIGNATED AGENTS.

CONNECTOR CITY 159 ORT LANE
THE VALUE OF CONNECTIONS MERLIN, OR 97532

TITLE:
**SMA FEMALE RIGHT ANGLE
 PCB SURFACE MOUNT**

MATERIAL:	TOLERANCES:	PROJECTION:
	.020 [0.50]-.200 [5.00]= ±.008 [0.20] .200 [5.00]-1.200 [30.00]= ±.016 [0.40] 1.20 [30.0]-4.75 [120.0]= ±.024 [0.60] 4.75 [120.0]-12.40 [315.0]= ±.040 [1.0]	ANGLER: ±1°
FINISH:	DRAWN: CJ	DT: 10/4/10
	ENGR:	DT:

SIZE	DWG. NO.	REV
A	CONSMA002-SMD	B
SCALE: 2:1	DO NOT SCALE DRAWING	SHEET 1 OF 1

LDFCDDC_A