

NOTES:

- DO NOT SCALE THIS DRAWING.
- MATERIALS OF CONSTRUCTION:**
 SHELL, HOUSING, COVER - BRASS (ASTM-B16 H02, C36000), GOLD PLATED (.000003 MIN)
 CONTACT PIN - BRASS (ASTM-B16 H02, C36000), GOLD PLATED (.000050 MIN)
 INSULATOR - PTFE, ASTM D 1710 OR EQUIV
 GASKET - SILICONE RUBBER, COLOR RED
 CRIMP FERRULE - COPPER ALLOY, GOLD PLATED (.000003 MIN)
 RETAINER RING - BeCu (QG-C-530), NATURAL
 HEAT SHRINK TUBING
- PERFORMANCE REQUIREMENTS:**
ELECTRICAL:
 FREQUENCY RANGE - DC TO 12.4 GHz
 VSWR - 1.500:1 MAX
 DWV - 750 VRMS
MECHANICAL:
 CENTER CONTACT RETENTION - 4 LBS MIN

901-9872		REVISIONS			
DRAWING NO.	REV	DESCRIPTION	DATE	ECO	APPR
THIRD ANGLE PROJ.	A	OFFICIAL ENG. RELEASE TO MFG.	4/7/95	40349	PB/RAV
	B	REDRAWN ON AUTO-CAD; ALL NOTES REWRITTEN & UPDATED	8/28/96	41519	CPM/BG
	C	SEE SHEET 1	12/17/98	41519	CPM/
	D	SEE SHEET 1	8-21-02	44182	CPM/

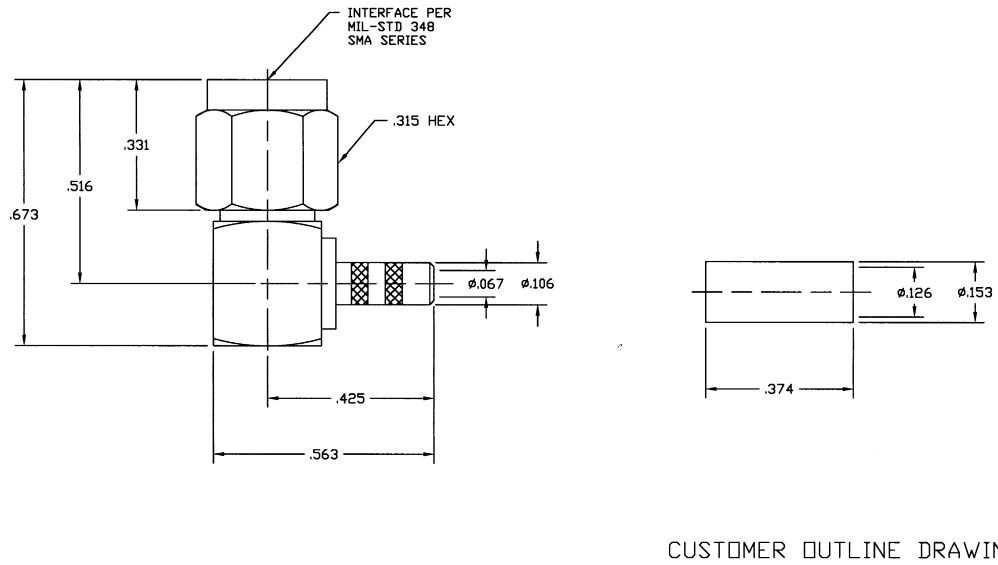

CUSTOMER OUTLINE DRAWING
 ALL OTHER SHEETS ARE FOR INTERNAL USE ONLY

UNLESS OTHERWISE SPECIFIED, DIMENSIONS ARE IN INCHES AND TOLERANCES ARE: 2 PLACE DECIMAL ±.015 (0,381 mm) 3 PLACE DECIMAL ±.005 (0,127 mm) ANGLES ± 1°	MATERIAL	DRAWN P. BRENZEL	DATE 12/8/94	TITLE SMA PLUG RIGHT ANGLE CRIMP TYPE FOR RG-174/U	Amphenol Amphenol Corporation RF/Microwave Operations Danbury, Conn. U.S.A. 06810	
	REFERENCE EAR 111-964413 EAR 966277-0	ENGINEER RAV	DATE 3/31/95	APPROVED B. GLEISSNER		DATE 8/23/96
NOTICE - These drawings, specifications, or other data (1) are, and remain the property of Amphenol Corp. (2) must be returned upon request; and (3) are confidential and not to be disclosed to any person other than those to whom they are given by Amphenol Corp. The furnishing of these drawings, specifications, or other data by Amphenol Corp., or to any other person for any purpose is not to be regarded by implication or otherwise in any manner licensing, granting rights or permitting such holder or any other person to manufacture, use or sell any product, process or design, patented or otherwise, that may in any way be related to or disclosed by said drawings, specifications, or other data.		CAD FILE H:\PETE\SM\901\ASSY\9872000C	CODE ID 74868	DWG SIZE B	DRAWING NO. 901-9872	REV D