

REV.	DATE	DESCRIPTION
A	01/30/04	UPDATE DRAWING FORMAT
B	11/08/05	ADD BODY BODY DIMENSION OF 22mm

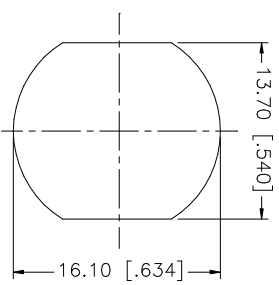

RECOMMENDED MOUNTING
HOLE DIMENSIONS

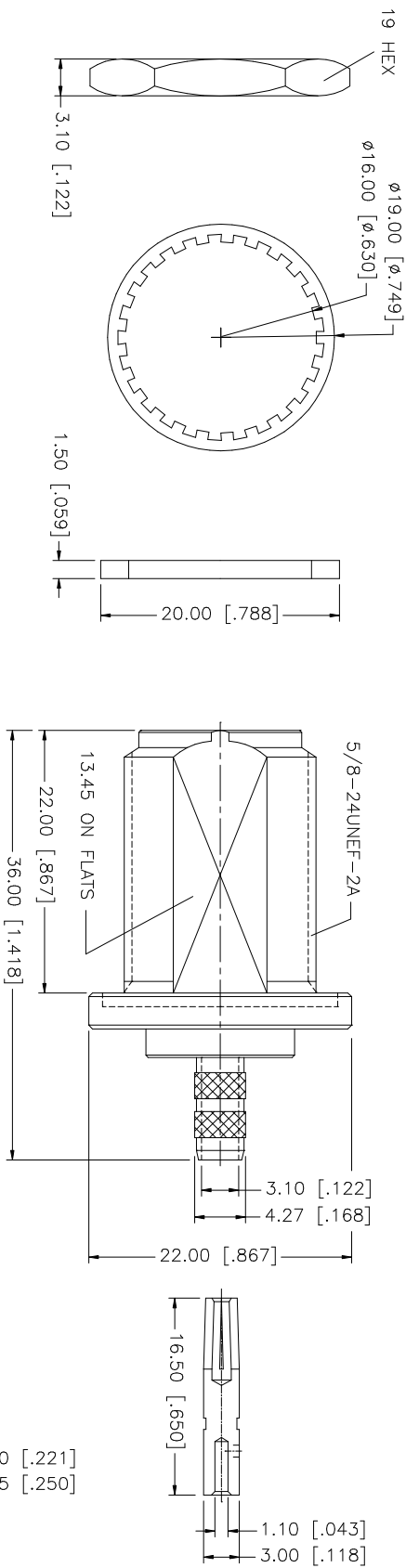
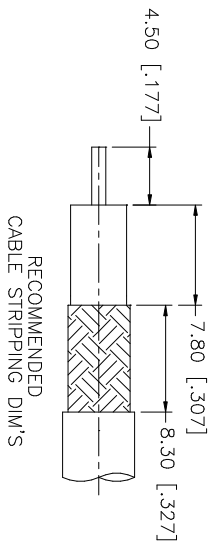

RECOMMENDED
CABLE STRIPPING DIM'S

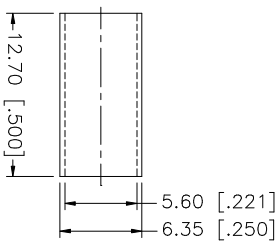

- NOTES:
1. CRIMPED FERRULE
HEX CRIMP SIZE .213"
 2. CRIMPED CONTACT PIN
HEX CRIMP SIZE .100"
 3. MAX. PANEL THICKNESS = 6.5mm
 4. RETURN LOSS: 22dB UP TO 4 GHz

QTY	FINISH	MATERIAL	DESCRIPTION
1	NEXCOTE	COPPER	FERRULE
1	RED	SILICONE	GASKET
1	NEXCOTE	BRASS	HEX NUT
1	NEXCOTE	BRASS	LOCK WASHER
1	GOLD	PHOS. BRONZE	CONTACT PIN
1	NATURAL	TEFLON	INSULATOR
1	NEXCOTE	BRASS	BODY

APPROVALS	DATE
DRAWN G.R.S.	11/08/05
CHECKED	
ISSUED	
SHEET 1 OF 1	

UNLESS OTHERWISE SPECIFIED DIMENSIONS ARE IN MILLIMETERS. DIMENSIONS IN [] ARE IN INCHES AND FOR CUSTOMER REFERENCE ONLY. TOLERANCES FOR MILLIMETERS ARE:
0.5 - 8mm ± 0.20mm
8 - 30mm ± 0.40mm
30 - 120mm ± 0.50mm
UNLESS OTHERWISE SPECIFIED TOLERANCES FOR INCHES ARE:
.020 - .315 = ± 0.007"
.315 - 1.180 = ± 0.015"
1.180 - 4.724 = ± 0.020"

DO NOT SCALE DRAWING
CAD FILE C:/172/172132.DWG

DWG. NO.	REV.	SIZE	SCALE
172132.DWG	B	A	NA

PART DESCRIPTION	PART NO.
N BULKHEAD CRIMP JACK (FOR RG-55/U, 142A/U, 223/U, 400/U)	172132