

REV.	DATE	DESCRIPTION
NC	03/21/04	UPDATE DRAWING FORMAT

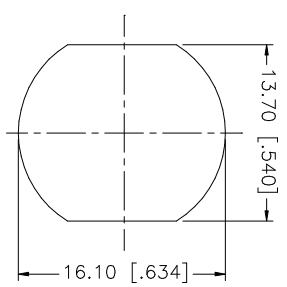

RECOMMENDED MOUNTING HOLE DIMENSIONS

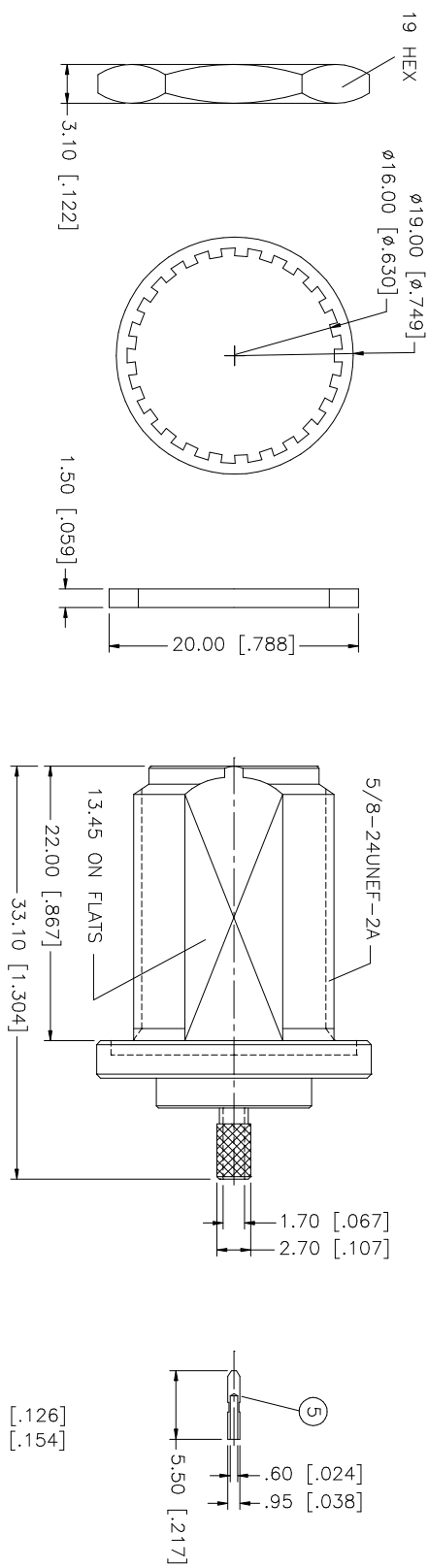
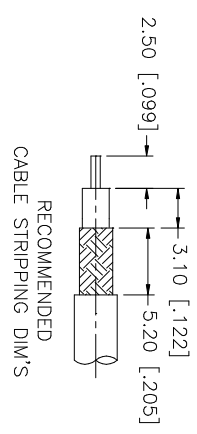

RECOMMENDED CABLE STRIPPING DIM'S

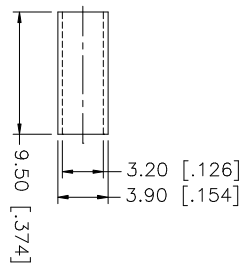

- NOTES:
1. CRIMPED FERRULE HEX CRIMP SIZE .128"
 2. CRIMPED CONTACT PIN SQ. CRIMP SIZE 0.7mm OR SOLDER
 3. MAX. PANEL THICKNESS = 6.5mm

QTY	FINISH	MATERIAL	DESCRIPTION
1	NEXCOTE	COPPER	FERRULE
1	RED	SILICONE	GASKET
1	NEXCOTE	BRASS	HEX NUT
1	NEXCOTE	BRASS	LOCK WASHER
1	GOLD	PHOS. BRONZE	CONTACT PIN
1	NATURAL	TEFLON	INSULATOR
1	NEXCOTE	BRASS	BODY

APPROVALS	DATE	PART DESCRIPTION
DRAWN G.R.S.	03/21/04	N REVERSE POLARITY BULKHEAD CRIMP JACK (FOR RG-174/U, 188A/U, 316/U)
CHECKED		
ISSUED		
SHEET 1 OF 1		

DO NOT SCALE DRAWING	CAD FILE	DWG. NO.	REV. NC	SIZE A	SCALE NA
	C:/172/172129RP.DWG	172129RP.DWG			

Amphenol Connex

N REVERSE POLARITY BULKHEAD CRIMP JACK (FOR RG-174/U, 188A/U, 316/U)

172129RP