

REV.	DATE	DESCRIPTION
A	02/24/03	UPDATE DRAWING FORMAT

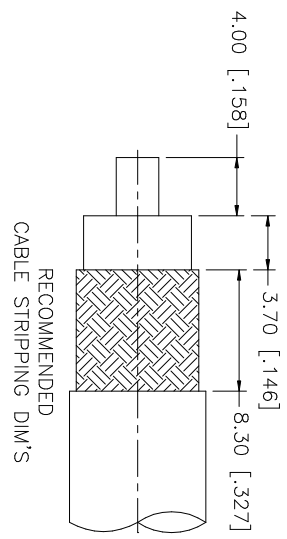
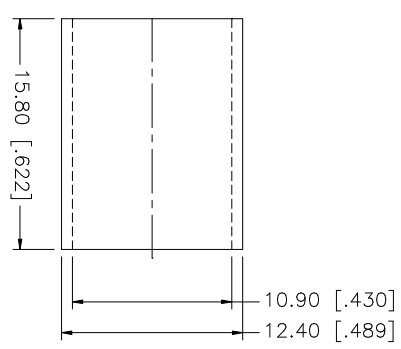
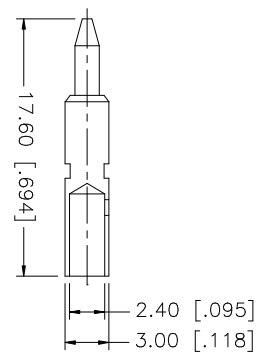
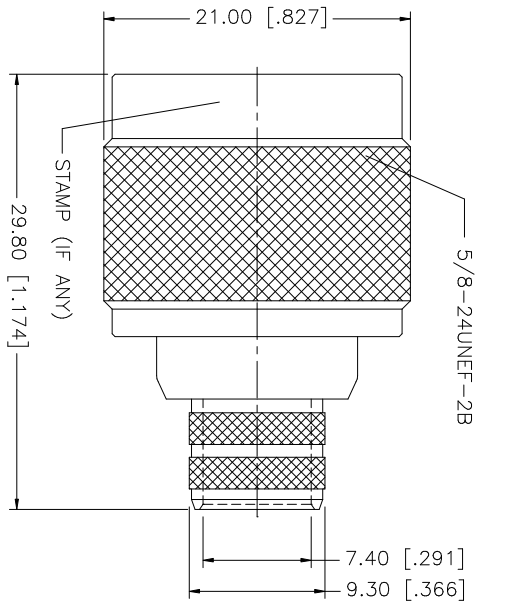

- NOTE:
1. CRIMPED FERRULE
HEX CRIMP SIZE .429"
 2. CRIMPED CONTACT PI
HEX CRIMP SIZE .100"

QTY	FINISH	MATERIAL	DESCRIPTION
1	NEXCOTE	BRASS	SHELL/BODY
1	NATURAL	TEFLON	INSULATOR
1	RED	SILICONE	GASKET
1	NATURAL	SUS 304	RETAINER RING
1	GOLD	BRASS	CONTACT PIN
1	NEXCOTE	COPPER	FERRULE

APPROVALS	DATE
DRAWN G.R.S.	02/24/03
CHECKED	
ISSUED	
SHEET 1 OF 1	

DO NOT SCALE DRAWING	CAD FILE	DWG. NO.	REV.	SIZE	SCALE
	C:/172/172102.DWG	172102.DWG	A	A	NA

UNLESS OTHERWISE SPECIFIED DIMENSIONS ARE IN MILLIMETERS. DIMENSIONS IN [] ARE IN INCHES AND FOR CUSTOMER REFERENCE ONLY.
UNLESS OTHERWISE SPECIFIED TOLERANCES FOR MILLIMETERS ARE: 0.5 - 8mm ± 0.20mm 8 - 30mm ± 0.40mm 30 - 120mm ± 0.50mm
UNLESS OTHERWISE SPECIFIED TOLERANCES FOR INCHES ARE: .020 - .315 = ± 0.007" .315 - 1.180 = ± 0.015" 1.180 - 4.724 = ± 0.020"

Amphenol Connex
N CRIMP PLUG (FOR RG-8/U, 213/U, 393/U CABLE)
172102