

REV.	DATE	DESCRIPTION
A	04/31/03	UPDATE DRAWING FORMAT

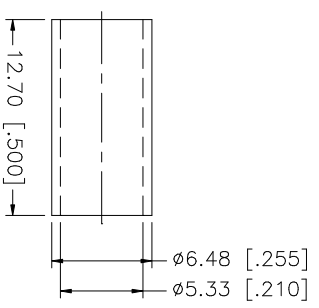
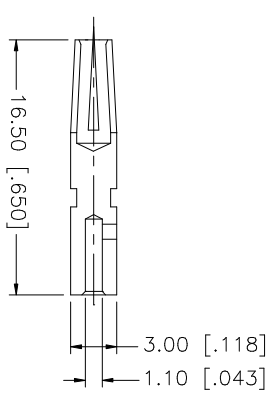
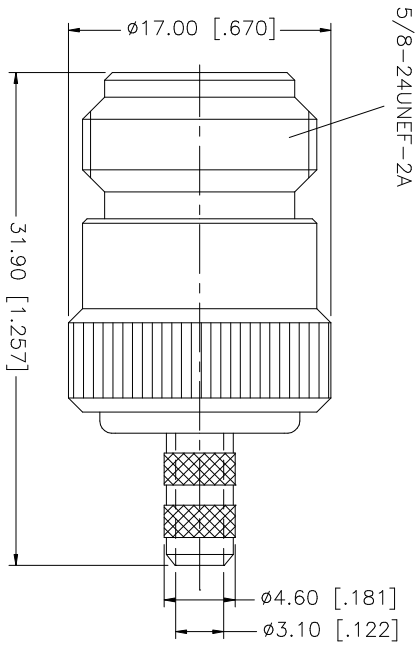
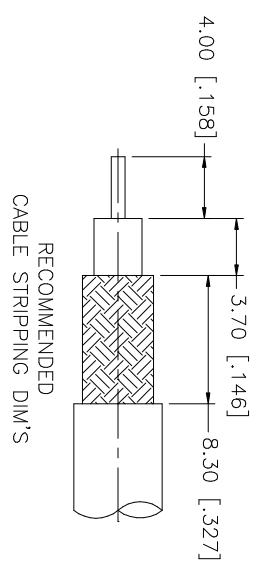

NOTE:

1. CRIMPED FERRULE
HEX CRIMP SIZE .213"
2. CRIMPED CONTACT PIN
HEX CRIMP SIZE .100"

Amphenol Connex

N CRIMP JACK
(FOR RG-58/U, 141/U CABLE)

172103

UNLESS OTHERWISE SPECIFIED DIMENSIONS ARE IN MILLIMETERS DIMENSIONS IN INCHES ARE IN PARENTHESES AND FOR ORDINARY PRACTICE ONLY	UNLESS OTHERWISE SPECIFIED TOLERANCES FOR MILLIMETERS ARE:	UNLESS OTHERWISE SPECIFIED TOLERANCES FOR INCHES ARE:	APPROVALS	DATE	PART DESCRIPTION
0.5 - 8mm ± 0.20mm	8 - 30mm ± 0.40mm	30 - 120mm ± 0.50mm	DRAWN	G.R.S.	04/31/03
0.20 - .315 = ± 0.007"	.315 - 1.180 = ± 0.015"	1.180 - 4.724 = ± 0.020"	CHECKED		
			ISSUED		
			SHEET	1 OF 1	
			CAD FILE	C:/172/172103.DWG	DWG. NO. 172103.DWG
					REV. A
					SIZE A
					SCALE NA

DESCRIPTION	MATERIAL	FINISH	QTY
1 BODY	BRASS	NEXCOTE	1
2 INSULATOR	TEFLON	NATURAL	1
3 CONTACT PIN	PHOS. BRONZE	GOLD	1
4 FERRULE	COPPER	NEXCOTE	1

DESCRIPTION	MATERIAL	FINISH	QTY
1 BODY	BRASS	NEXCOTE	1
2 INSULATOR	TEFLON	NATURAL	1
3 CONTACT PIN	PHOS. BRONZE	GOLD	1
4 FERRULE	COPPER	NEXCOTE	1