

NOTES:

1. PLATING MUST CONFORM TO AMPHENOL SPEC. 349-50560. CONTACT & BODY ARE GOLD PLATED; COUPLING NUT IS PASSIVATED (REF)
2. FOR ASSEMBLY INSTRUCTIONS SEE AMPHENOL SPEC. 349-50114, SHEET 21.
3. VSWR: 1.29 MAX FROM DC TO 26.5 GHz.
4. SOCKET CHARACTERISTICS: USING STEEL TEST PINS WITH A 16 MICROINCH FINISH CHAMFERED 45° INSERTION FORCE: 3 LBS MAX WITH A .0210 +.0002/- .0000 DIA PIN WITHDRAWAL FORCE: 1 OZ MIN WITH A .0190 +.0000/- .0002 DIA PIN

901-9723		REVISIONS			
DRAWING NO.	REV	DESCRIPTION	DATE	ECO	APPR
THIRD ANGLE PROJ.	A	RELEASE TO MFG.	1/5/90	36980	TA/PB
	S	SEE SHEET I	5/30/02	44060	CPM
	T	SEE SHEET I	1/8/04	44755	CPM
	U	SEE SHEET I	3/11/05	45445	CPM

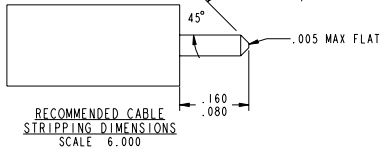
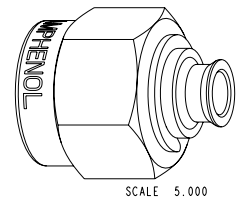
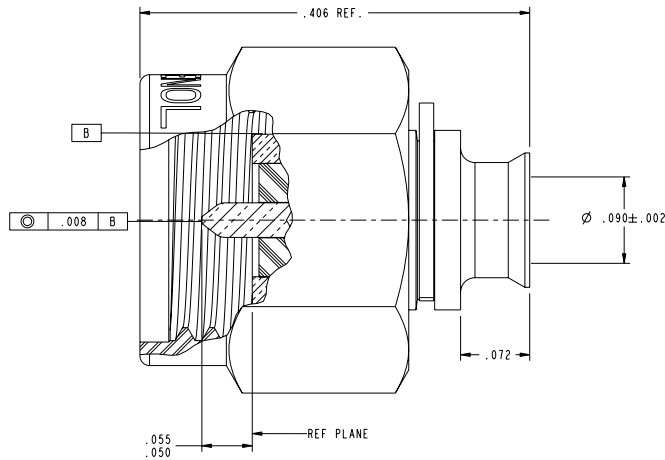
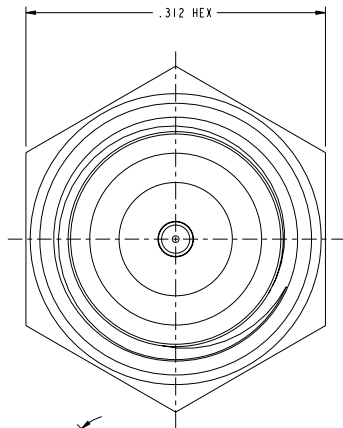

CUSTOMER OUTLINE DRAWING  
ALL OTHER SHEETS ARE FOR INTERNAL USE ONLY

UNLESS OTHERWISE SPECIFIED, DIMENSIONS ARE IN INCHES AND TOLERANCES ARE: 2 PLACE DECIMAL ±.015 (0.381 mm)    3 PLACE DECIMAL ±.005 (0.127 mm)    ANGLES ± 1° NOTICE - These drawings, specifications, or other data (1) are, and remain the property of Amphenol Corp. (2) must be returned upon request; and (3) are confidential and not to be disclosed to any person other than those to whom they are given by Amphenol Corp. The furnishing of these drawings, specifications, or other data by Amphenol Corp., or to any other person for any purpose is not to be regarded by implication or otherwise in any manner licensing, granting rights or permitting such holder or any other person to manufacture, use or sell any product, process or design, patented or otherwise, that may in any way be related to or disclosed by said drawings, specifications, or other data.	MATERIAL  REFERENCE EAR 111-961386 3; & 571 H-P 1250-1578 REV H A-5951-1654-1 615X-864-200	DRAWN C. McGRATH	DATE 14-May-02	TITLE SMA PLUG SOLDER TYPE .086 SEMI-RIGID	<b>Amphenol RF</b> Danbury, CT, USA Tainan, Taiwan Shenzhen, China www.amphenolrf.com
		ENGINEER O. BARTHELMES	DATE 14-May-02		
		CAD FILE I:\SMA\901-9723	CODE ID 74868	DWG SIZE B	DRAWING NO. 901-9723
				SCALE: 10.0:1	SHEET 2 OF 2
				REV U	