

Description

Type F connectors serve a low cost market with prices from \$0.50 to \$0.95. Amphenol provides a high performance alternative. All connectors comply with a 3/8-32 thread specification.

The Type F is similar to the Type G except it is threaded rather than snap-on. Primary applications are for cable television (CATV), set top boxes, and cable modems.

With the deployment of 750 MHz Hybrid Fiber Coax (HFC) networks, it became increasingly obvious that existing low performance F receptacles could not be used in high speed cable modems and customer interface units (CIUs). The industry has challenged connector manufacturers to develop high performance connectors featuring -30 dB return loss at 1 GHz. Additionally, these high performance connectors must still accept .022-.042 in. diameter conductors.

Features/Benefits

- Patent pending contact design provides a truly cylindrical coaxial contact and provides superior RF performance and excellent insertion/withdrawal characteristics.
- 30 dB return loss to 1 GHz ensures a high performance specification that outperforms competition.
- Multiple PCB mount packages: surface mount, edge mount, right angle and straight, meets many customer applications needs.
- Accommodates .022 - .042 inch center conductor sizes. One connector accommodates a wide range of cable sizes reducing part numbers.



Applications

- Cable Assemblies
- CATV
- CIMs
- Head End Equipment
- High Speed Cable Modems
- Hybrid Fiber Coax Networks
- Set Top Boxes

Type F Receptacles

Specifications	246
Receptacles	247
Jacks	248-249

Type F Adapters

Specifications	250
Adapters	251

SCTE Type F

Specifications	252
----------------	-----

SPECIFICATIONS

Impedance:	75 ohms
RF Leakage:	-100 dB min. @ 1 GHz
Temperature Range:	-40°F to +140°F (-40°C to +60°C)

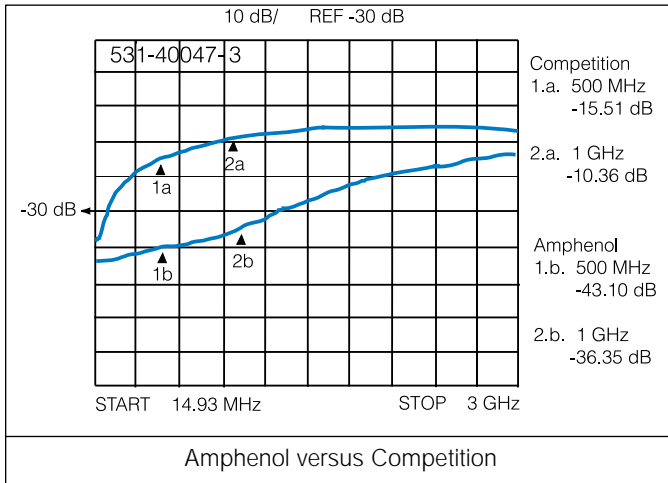

Amphenol Number	Frequency Range	Return Loss
531-40001	0-1 GHz 1-3 GHz	30 dB minimum 15 dB minimum
531-40035-1006	0-1 GHz 1-3 GHz	20 dB minimum 10 dB minimum
531-40039	0-1 GHz 1-3 GHz	30 dB minimum 15 dB minimum
531-40046	0-1 GHz 1-3 GHz	30 dB minimum 15 dB minimum
531-40047-3	0-1 GHz 1-3 GHz	30 dB minimum 15 dB minimum

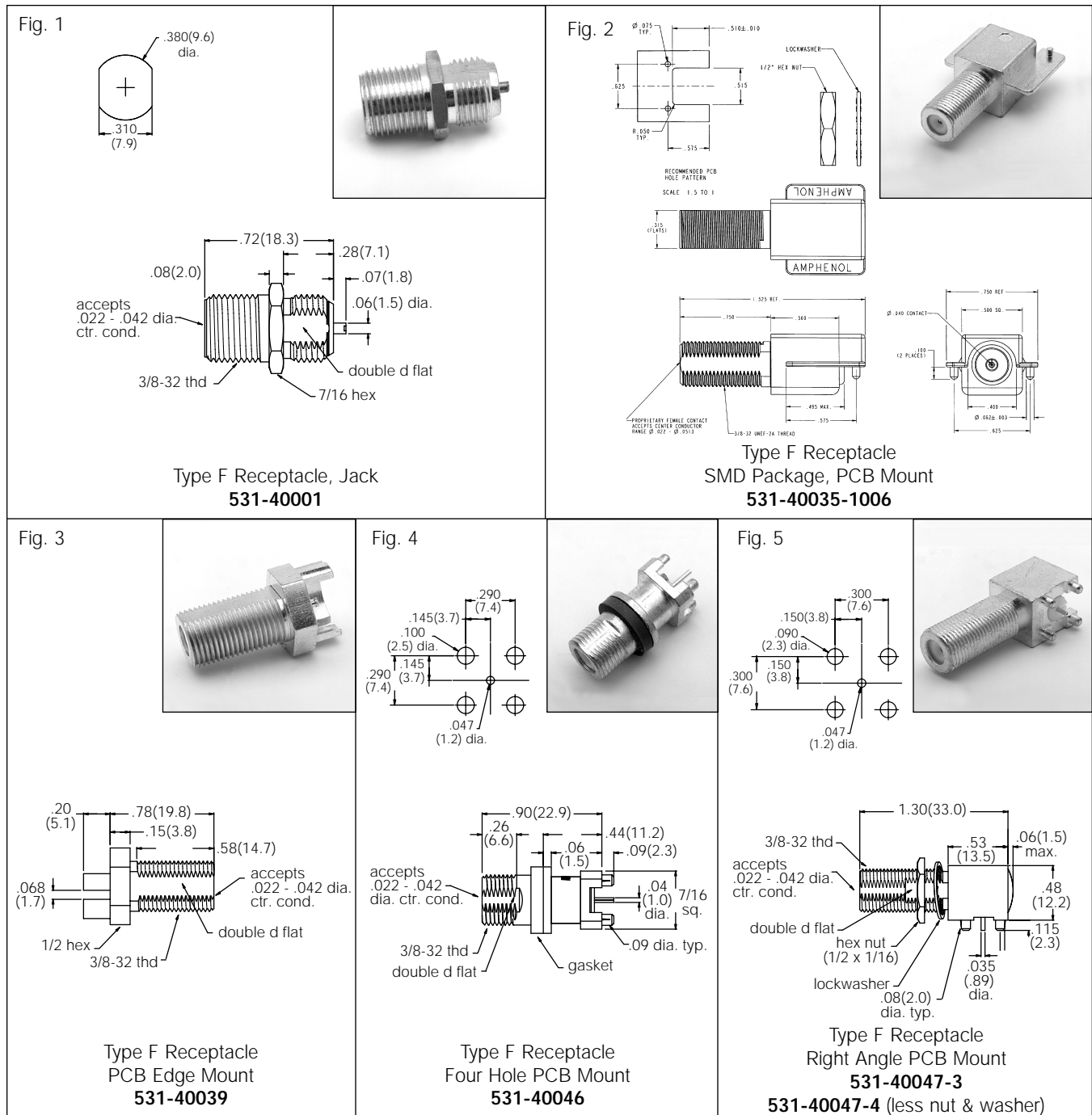

Amphenol Number	Materials			Terminal Type	Fig.
	Body (plating)	Contact (plating)	Insulator		
531-40001	brass (tin lead)	phosphor bronze (tin lead)	PTFE	Flat Tab	1
531-40035-1006	zinc die cast (tin lead)	beryllium copper (tin lead)	PTFE	Flat Tab	2
531-40039	brass (tin lead)	phosphor bronze (tin lead)	PTFE	Round	3
531-40046	zinc die cast (tin lead)	phosphor bronze (tin lead)	Polypropylene	Round	4
531-40047-3	zinc die cast (tin lead)	phosphor bronze (tin lead)	Polypropylene	Round	5
531-40047-4	zinc die cast (tin lead)	phosphor bronze (tin lead)	Polypropylene	Round	5

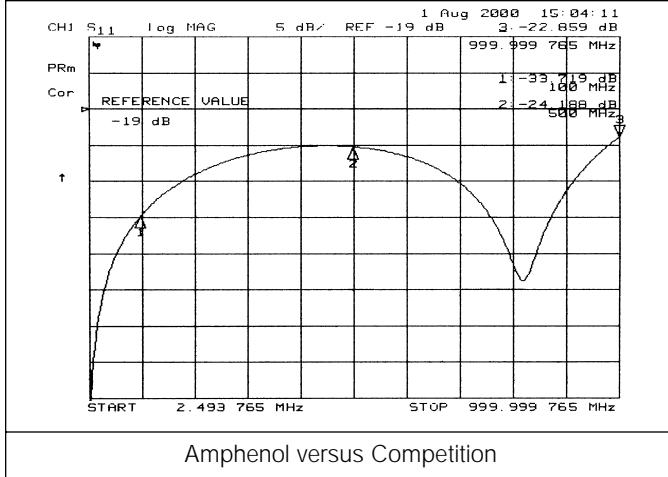

Amphenol Number	Frequency Range	Return Loss
531-40078	0-1.0 GHz	19 dB minimum
531-40078-1	0-1.0 GHz	19 dB minimum
531-40084	0-1.0 GHz	19 dB minimum
531-40084-1	0-1.0 GHz	19 dB minimum

SPECIFICATIONS

Impedance	75 ohms
Frequency range	0-1 GHz
RF Leakage	-100 dB min. @ 1 GHz
Temperature Range	-40°F to -140°F (-40°C to +60°C)
Coupling Nuts and Bodies	Brass
Contact	Be Cu
Ferrule	Brass
Insulator	Polypropylene

Plating	Body: tin lead plate Contact: bright tin plated Ferrule: tin-lead
Mating	3/8-32 threaded
Cable Attachment	Hex braid-crimp
Cable Retention	20lb. min.

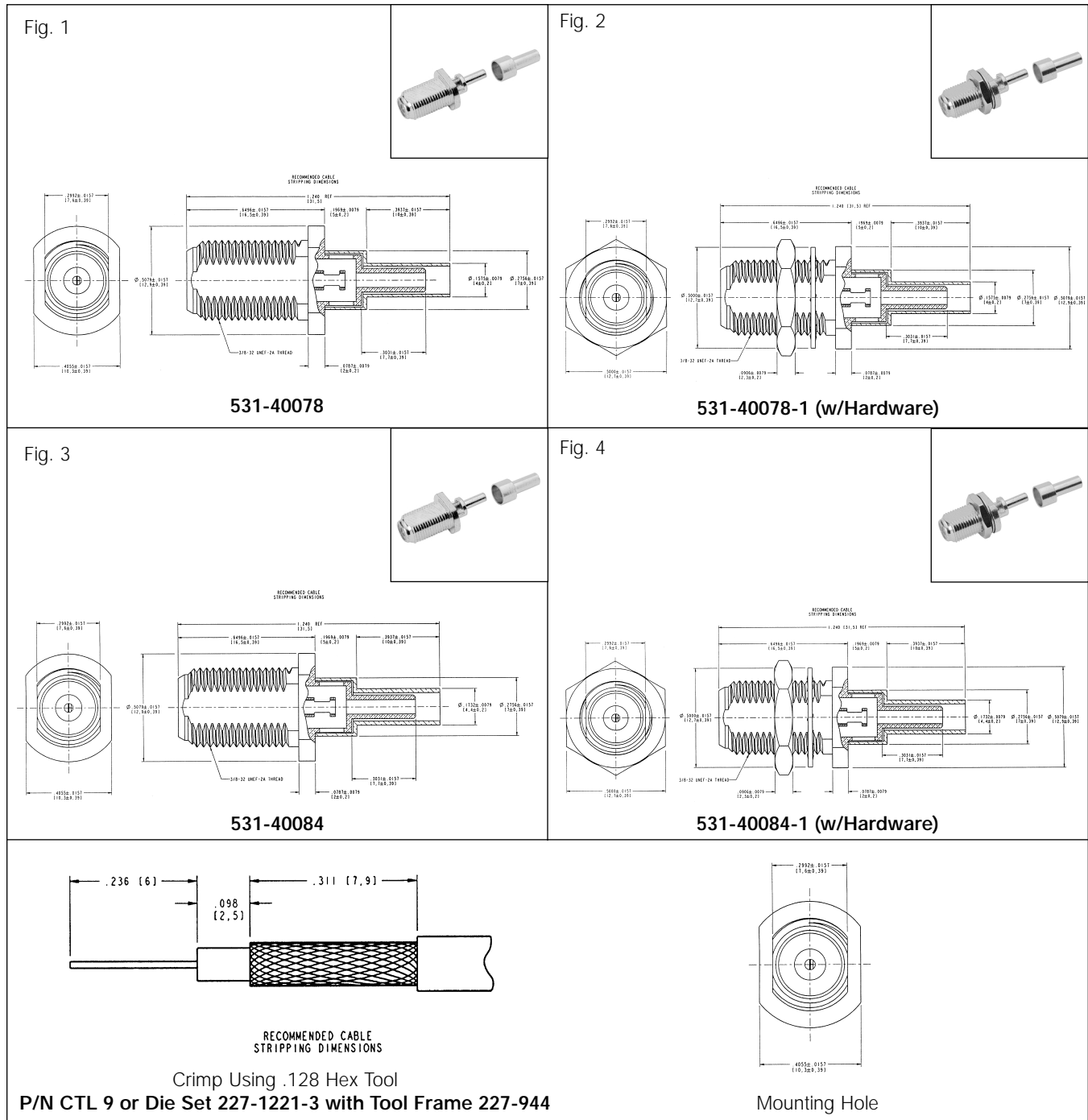

Amphenol Number	Materials			Cable Type	Fig.
	Body (plating)	Contact (plating)	Insulator		
531-40078	Brass (Tin-lead)	BeCu (Bright tin)	Polypolyene	RG179	1
531-40078-1	Brass (Tin-lead)	BeCu (Bright tin)	Polypolyene	RG179	2
531-40084	Brass (Tin-lead)	BeCu (Bright tin)	Polypolyene	RD179	3
531-40084-1	Brass (Tin-lead)	BeCu (Bright tin)	Polypolyene	RD179	4

Description

Amphenol offers an assortment of Type F and G coaxial adapters designed to meet application specific needs of equipment designers.

With the deployment of 750 MHz Hybrid Fiber Coax (HFC) networks, it became increasingly obvious that existing low performance adapters and receptacles could not be used in the new high performance equipment. A need for high performance connectors featuring -30 dB at 1 GHz and -20 dB at 3 GHz became a reality. Additionally, these high performance connectors must still accept .022-.042 in. diameter conductors.

Working with industry leaders, Amphenol has developed a variety of F and G adapters for use on high performance equipment. These connectors utilize Amphenol's unique patented female contact design featuring a true cylindrical phosphorous bronze coaxial contact. As a result, superior RF performance and excellent insertion/withdrawal characteristics for .022-.042 in. diameter center conductors are achieved.

The F and G adapters are available in multiple styles including straight and right angle PCB mount as well as SMD versions.

All connectors comply with the 3/8-32 UNEF Thread Specification and the MIL-Std. 202 Specification for vibration, shock, thermal shock, moisture resistance and salt spray.

Features/Benefits

- Patent pending contact design provides a truly cylindrical coaxial contact.
- 30 dB return loss to 3 GHz.
- Accommodate .022-.042 in. center conductor sizes.

Applications

- High Speed Modems
- CIMs
- Hybrid Fiber Coax Networks
- CATV
- Head End Equipment
- Set Top Boxes

SPECIFICATIONS

Impedance:	75 ohms
RF Leakage:	-100 dB min. @ 1 GHz
Temperature Range:	-40°F to +140°F (-40°C to +60°C)

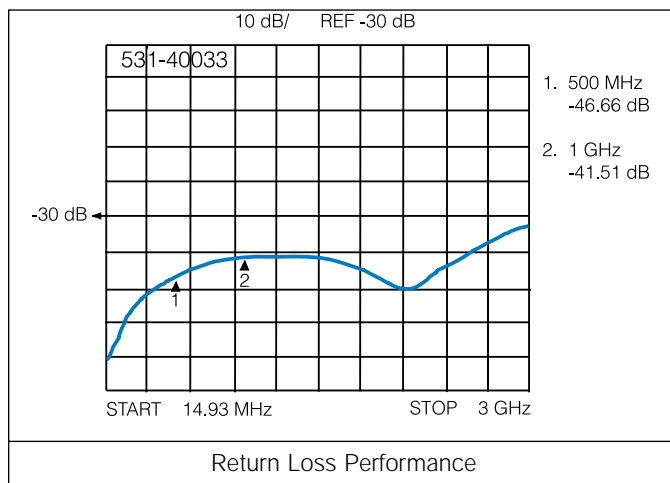

Amphenol Number	Frequency Range	Return Loss
531-40008	0-3 GHz	30 dB minimum
531-40033	0-3 GHz	36 dB minimum
531-40010	0-3 GHz	30 dB minimum
531-40009	0-3 GHz	36 dB minimum

Type F Connectors

SCTE Type F Specifications

IPS-SP-400
Recommended "F" Jack (Port)

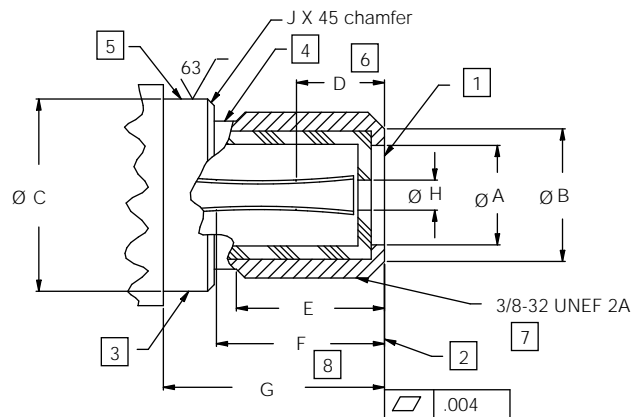

Description	DIM	mm		in		Notes
		min	max	min	max	
Face opening inner diameter	A	4.32	6.10	.170	.240	
Face outer diameter	B	7.11	8.00	.280	.315	
Base outer diameter	C	9.40	11.05	.370	.435	
Center conductor contact to face length	D	—	5.08	—	.200	6
Port threaded length	E	8.26	8.89	.325	.350	
Center contact depth	F	9.65	—	.380	—	8
Sealing surface to face length	G	12.07	13.21	.475	.520	
Center conductor guide inner diameter	H	—	1.73	—	.068	
Chamfer break	J	0.25	0.76	.010	.030	

NOTES:

1. Dielectric must not protrude beyond reference plane after installation
2. Reference plane after installation on standard port tightened to 30 inch lbs and removed
3. No casting lines permitted
4. Thread relief not to exceed 1 full thread
5. Finish required for port seal ring
6. Dimension to point of positive contact of terminal
7. ANSI specification B1.1 (major dia 0.368/0.374)
8. Limit of clearance for maximum center conductor
9. Recommended center conductor 0.0513 in maximum

IPS-SP-401
Recommended "F" Plug

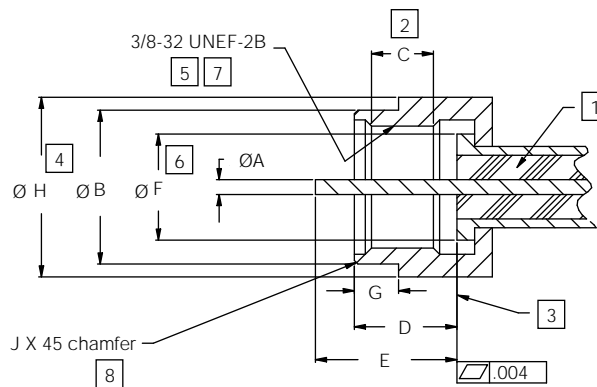

Description	DIM	mm		in		Notes
		min	max	min	max	
Cable center conductor diameter	A	0.56	1.07	.022	.042	
Nut outer diameter	B	10.41	11.05	.410	.435	
Nut threaded length	C	—	—	—	—	2
Mandrel face depth to nut leading edge	D	4.45	6.10	.175	.240	
Center conductor to mandrel face length	E	6.35	9.53	.250	.375	
Mandrel face outer diameter	F	7.11	—	.280	—	6
Nut to sealing sleeve interface length	G	1.78	4.45	.070	.175	
Maximum envelope dimension	H	—	12.90	—	.508	4
Chamfer break	J	—	0.25	—	.010	8

NOTES:

1. Dielectric must not protrude beyond reference plane
2. Minimum 4 full threads
3. Reference plane after installation on standard port, tightened to 30 inch pounds and removed
4. Maximum envelope dimension
5. Maximum 1 thread lead-in
6. Minimum diameter of reference plane
7. ANSI specification B1.1
8. Radius optional
9. Connectors must withstand a minimum torque of 60 inch pounds without damage per IPS-TP-400

*many Amphenol Type F connectors comply to the above specifications.