

REV.	DATE	DESCRIPTION
A	06/29/04	UPDATE DRAWING FORMAT
B	03/27/05	ADD 17.5 HEX DIMNSION

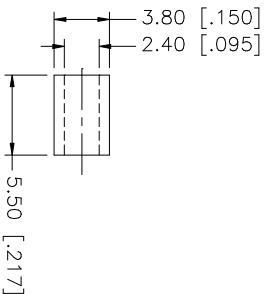
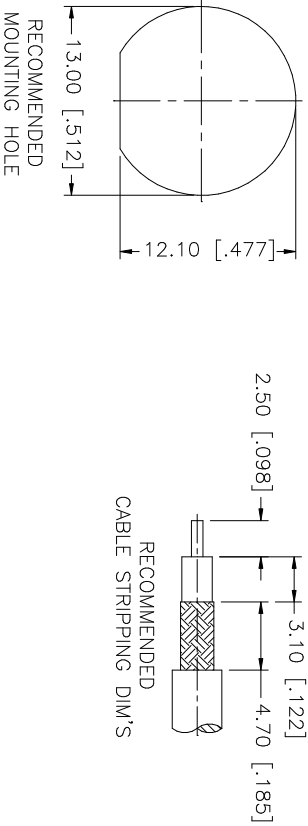
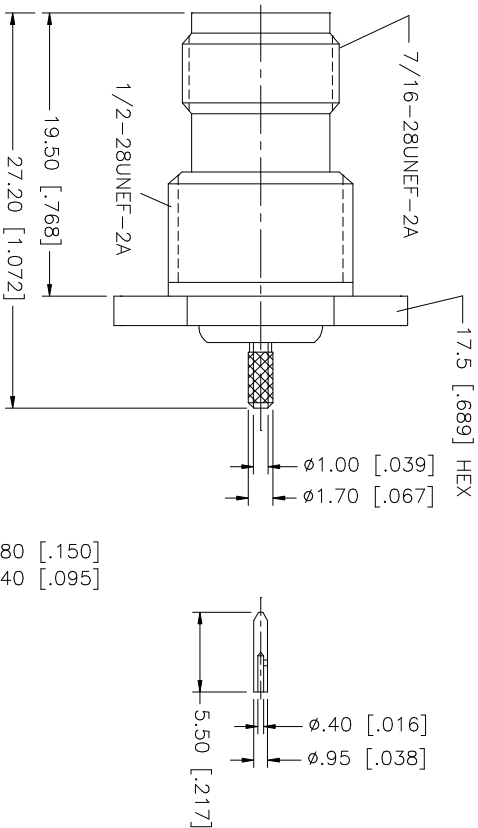
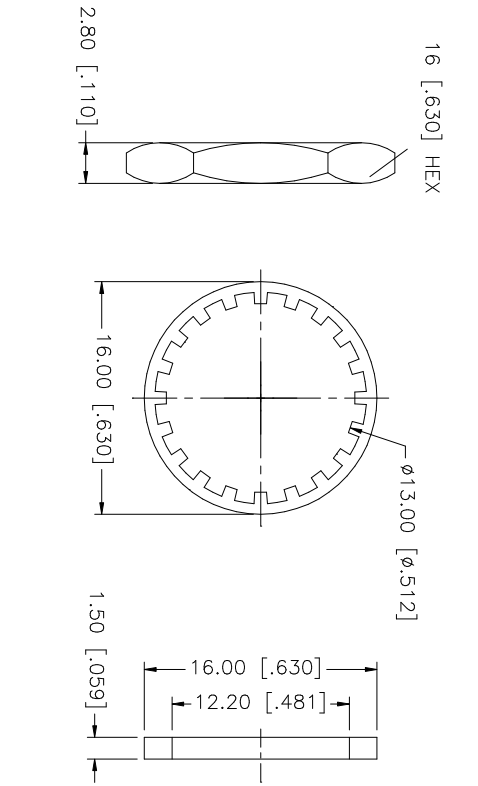

CRIMP NOTES:

1. CRIMPED FERRULE
HEX CRIMP SIZE .128"
2. CRIMPED CONTACT PIN
SQ. CRIMP SIZE .7mm
3. MAX. PANEL THICKNESS= 5.5mm

QTY	DESCRIPTION	MATERIAL	FINISH	DO NOT SCALE DRAWING	CAD FILE	DWG. NO.	REV.	SIZE	SCALE
1	INSULATOR	DELIRIN	NATURAL	1	C:/122/122370.DWG	122370.DWG	B	A	NA
1	BODY	BRASS	NICKEL	1					
1	CONTACT PIN	BRASS	GOLD	1					
1	GASKET	RUBBER	RED	1					
1	LOCK WASHER	BRASS	NICKEL	1					
1	HEX NUT	BRASS	NICKEL	1					
1	FERRULE	COPPER	NICKEL	1					

UNLESS OTHERWISE SPECIFIED DIMENSIONS ARE IN MILLIMETERS. DIMENSIONS IN [] ARE IN INCHES AND FOR CUSTOMER REFERENCE ONLY. TOLERANCES FOR MILLIMETERS ARE:
0.5 - 8mm ± 0.20mm
8 - 30mm ± 0.40mm
30 - 120mm ± 0.50mm

UNLESS OTHERWISE SPECIFIED TOLERANCES FOR INCHES ARE:
.020 - .315 = ± 0.007"
.315 - 1.180 = ± 0.015"
1.180 - 4.724 = ± 0.020"

APPROVALS: G.R.S. DATE: 03/27/05

CHECKED: ISSUED: SHEET 1 OF 1

PART DESCRIPTION: TNC BULKHEAD CRIMP JACK (FOR RG-178B/U, 196A/U CABLE)

PART NO.: 122370

Amphenol Connex