

REV.	DATE	DESCRIPTION
A	10/28/99	MODIFY BODY AND CONTACT DIMS
B	01/13/03	ADD INSULATOR / UPDATE DIMENSIONS

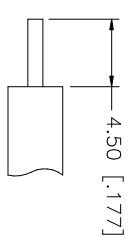

RECOMMENDED
CABLE STRIPPING DIM'S

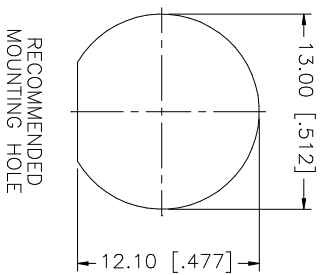
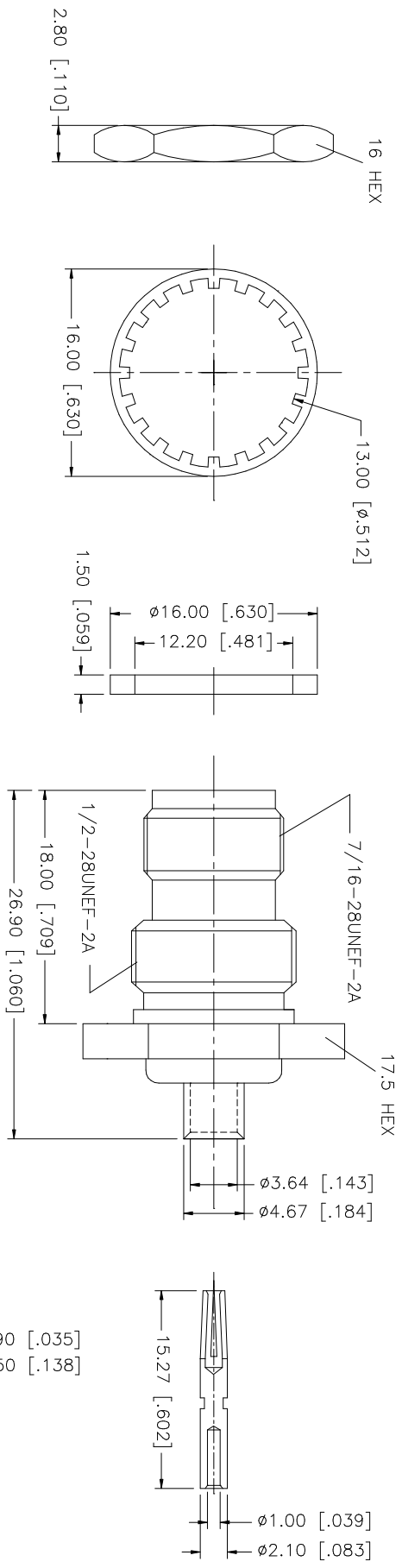
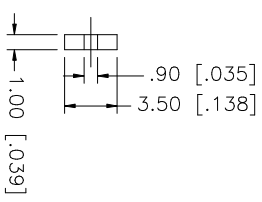

QTY	FINISH	MATERIAL	DESCRIPTION
1	RED	RUBBER	GASKET
1	NICKEL	BRASS	LOCK WASHER
1	NICKEL	BRASS	HEX NUT
1	GOLD	BRASS	BARREL
1	GOLD	PHOS. BRONZE	CONTACT PIN
2	NATURAL	TEFLON	INSULATOR
1	GOLD	BRASS	REAR BODY
1	NICKEL	BRASS	BODY

APPROVALS	DATE
DRAWN G.R.S.	01/13/03
CHECKED	
ISSUED	
SHEET 1 OF 1	

PART DESCRIPTION	PART NO.
TNC BULKHEAD DIRECT SOLDER JACK .141" SIMI RIGID CABLE	122401

UNLESS OTHERWISE SPECIFIED DIMENSIONS ARE IN INCHES AND FOR CUSTOMER REFERENCE ONLY.
TOLERANCES FOR MILLIMETERS ARE: 0.5 - 8mm ± 0.20mm 8 - 30mm ± 0.40mm 30 - 120mm ± 0.50mm
UNLESS OTHERWISE SPECIFIED DIMENSIONS FOR INCHES ARE: .020 - .315 = ± 0.007" .315 - 1.180 = ± 0.015" 1.180 - 4.724 = ± 0.020"

DO NOT SCALE DRAWING

CAD FILE	DWG. NO.	REV.	SIZE	SCALE
C:/122/122401.DWG	122401.DWG	B	A	NA

Amphenol Connex