

REV.	DATE	DESCRIPTION
A	02/28/02	MODIFY CONTACT PIN AND BODY LENGTH
B	04/04/03	UPDATE DRAWING FORMAT

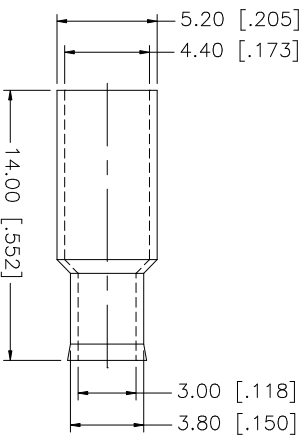
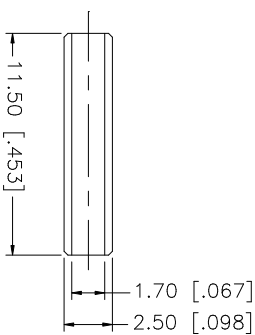
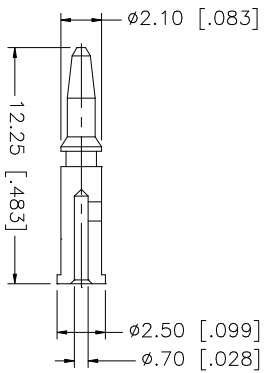
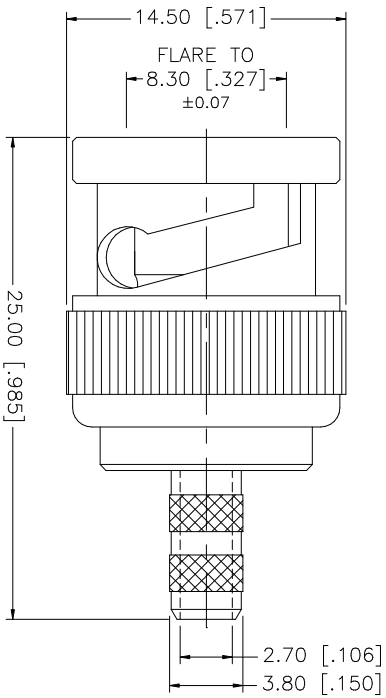
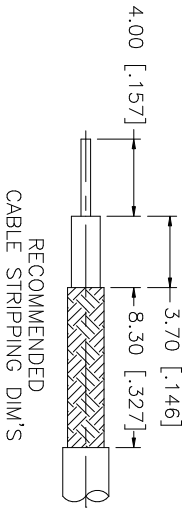

- CRIMP NOTES:
1. CRIMPED FERRULE
HEX CRIMP SIZE .178"
 2. CRIMPED CONTACT PIN
HEX CRIMP SIZE .068"

QTY	FINISH	MATERIAL	DESCRIPTION
1	NICKEL	COPPER	FERRULE
1	NATURAL	DELIRIN	SLEEVE
1	GOLD	BRASS	CONTACT PIN
1	NATURAL	DELIRIN	INSULATOR
1	NICKEL	BRASS	SHELL/BODY

APPROVALS	DATE
G.R.S.	04/04/03

UNLESS OTHERWISE SPECIFIED DIMENSIONS ARE IN MILLIMETERS. DIMENSIONS IN [] ARE IN INCHES AND FOR CUSTOMER REFERENCE ONLY.
UNLESS OTHERWISE SPECIFIED TOLERANCES FOR MILLIMETERS ARE: 0.5 - 30mm ± 0.20mm 30 - 120mm ± 0.30mm
UNLESS OTHERWISE SPECIFIED TOLERANCES FOR INCHES ARE: .020 - .315 = ± 0.007" .315 - 1.180 = ± 0.015" 1.180 - 4.724 = ± 0.020"

CAD FILE	DWG. NO.	REV.	SIZE	SCALE
C:/112/112132.DWG	112132.DWG	B	A	NA

PART DESCRIPTION	PART NO.
BNC CRIMP PLUG - 50 ohms (RG 174/U, 188/U, 316/U CABLE)	112132

Amphenol Connex