

APPLICABLE STANDARD						
RATING	OPERATING TEMPERATURE RANGE	-40°C TO +85°C	STORAGE TEMPERATURE RANGE	-40°C TO +85°C (NO CONDENSATION)		
	POWER	4 W	CHARACTERISTIC IMPEDANCE	50 Ω		
	FREQUENCY RANGE	DC TO 10 GHz	OPERATING HUMIDITY RANGE	TO 90%		
	PECULIARITY	—	APPLICABLE CABLE	1.5D-HQEW		
SPECIFICATIONS						
ITEM	TEST METHOD		REQUIREMENTS	QT	AT	
CONSTRUCTION						
GENERAL EXAMINATION	VISUALLY AND BY MEASURING INSTRUMENT.		ACCORDING TO DRAWING.	×	×	
MARKING	CONFIRMED VISUALLY.					
ELECTRIC CHARACTERISTICS						
CONTACT RESISTANCE	100 mA MAX (DC OR 1000 Hz).		CENTER CONTACT	100 mΩ MAX.	×	— △
			OUTER CONTACT	100 mΩ MAX.		
INSULATION RESISTANCE	100 V DC.		1000 MΩ MIN.		×	—
VOLTAGE PROOF	100 V AC FOR 1 min.		NO FLASHOVER OR BREAKDOWN.		×	×
V.S.W.R.	※1	FREQUENCY DC TO 3 GHz	1.3 MAX		×	—
		FREQUENCY 3 TO 6 GHz	1.7 MAX			
		FREQUENCY 6 TO 10 GHz	2.2 MAX			
INSERTION LOSS	FREQUENCY TO GHz		MAX.		×	—
ISOLATION	FREQUENCY TO GHz		MIN.		×	—
MECHANICAL CHARACTERISTICS						
MECHANICAL OPERATION	12,000 TIMES INSERTIONS AND EXTRACTIONS.		1) CONTACT RESISTANCE CENTER CONTACT: 100mΩMAX. OUTER CONTACT: 100mΩMAX.	×	—	
VIBRATION	FREQUENCY 10 TO 55 Hz SINGLE AMPLITUDE 0.75 mm OR 98 m/s <sup>2</sup> 1 octave/min, 10 CYCLES FOR EACH 3 DIRECTIONS.		1) NO ELECTRICAL DISCONTINUITY OF 1μs. 2) CONTACT RESISTANCE CENTER CONTACT: 100mΩMAX. OUTER CONTACT: 100mΩMAX.	×	—	
SHOCK	ACCELERATION: 490 m/s <sup>2</sup> DURATION: 11 ms, HALF SINE WAVE 3 BOTH AXIAL DIRECTIONS, 3 TIMES EACH		3) NO DAMAGE, CRACK AND LOOSENESS OF PARTS.	×	—	
CABLE-CLAMP RESISTANCE SHOCK	THE APPLICABLE CABLE MUST BE CONNECTED AND BE SUITABLE FOR THE STD VALUE.		49 N MIN		×	—
ENVIRONMENTAL CHARACTERISTICS						
RAPID CHANGE OF TEMPERATURE	TEMPERATURE -55 → -15 → -35 → +85 → -15 → -35 °C TIME 30 → 2-3 → 30 → 2-3 min. UNDER 100 CYCLES AND LEAVE IT FOR ONE HOUR OR TWO.		1) CONTACT RESISTANCE CENTER CONTACT: 100mΩMAX. OUTER CONTACT: 100mΩMAX. 2) INSULATION RESISTANCE: 10 MΩ MIN. 3) NO DAMAGE, CRACK AND LOOSENESS OF PARTS.	×	—	
DRY HEAT	EXPOSED AT +85°C, 96h.		1) CONTACT RESISTANCE CENTER CONTACT: 100mΩMAX. OUTER CONTACT: 100mΩMAX. 2) INSULATION RESISTANCE: 10 MΩ MIN. 3) NO DAMAGE, CRACK AND LOOSENESS OF PARTS.	×	—	
	COUNT	DESCRIPTION OF REVISIONS	DESIGNED	CHECKED	DATE	
▲		DIS-J-000280	YH.MATSUO	TY.OZAKI	05.11.22	
REMARK			APPROVED	KJ.KAWAMURA	05.08.25	
※1. STD VALUE.			CHECKED	TY.OZAKI	05.08.25	
RECEPTACLE + PLUG + CABLE + SMA CONNECTOR			DESIGNED	YH.MATSUO	05.08.25	
MS-162 MS-162-C(LP)-1 1.5D-HQEW(L=40mm) HRM-200-1.5WJBN			DRAWN	YH.MATSUO	05.08.25	
Unless otherwise specified, refer to IEC-60512.						
Note QT:Qualification Test AT:Assurance Test ×:Applicable Test			DRAWING NO.		ELC4-180547-00	
<b>HRS</b>	SPECIFICATION SHEET		PART NO.	MS-162-C(LP)-1		
	HIROSE ELECTRIC CO., LTD.		CODE NO.	CL358-0222-4-00	△ 1/1	

DRAWING FOR REFERENCE: This is subject to change without notice

2011/02/07 13:54:59 TH. HIJINO

FORM HD0011-2-1

2011/02/07 13:55:00 TH. HIJINO

DRAWING FOR REFERENCE: This is subject to change without notice

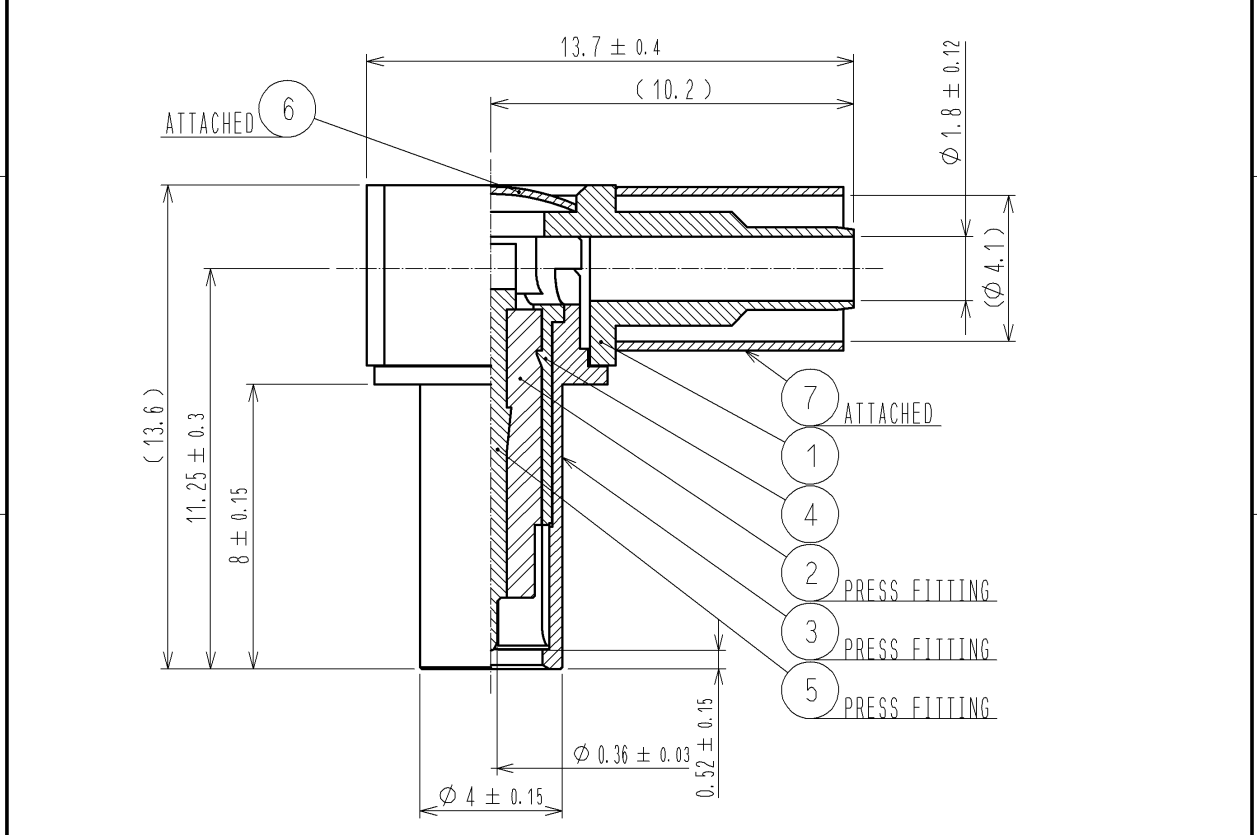
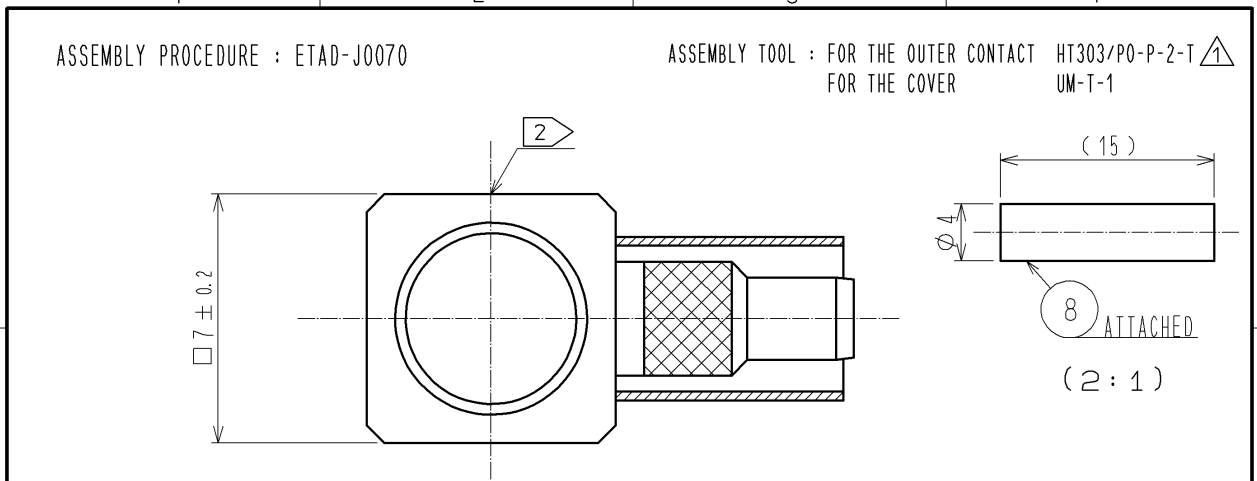

NOTE 1. FOR THE USE OF THIS PRODUCT, PUSH IT ON MS-162  
 2 MARKING HRS

4	PHOSHOR BRONZE	NICKEL	8	POLYOLEFIN	HEAT SHRINK TUBING		
3	PHOSHOR BRONZE	NICKEL	7	COPPER	NICKEL		
2	PTFE		6	BRASS	NICKEL		
1	BRASS	NICKEL	5	PHOSHOR BRONZE	GOLD		
NO.	MATERIAL	FINISH .	REMARKS	NO.	MATERIAL	FINISH .	REMARKS

UNITS mm		SCALE 5 : 1	COUNT 1	DESCRIPTION OF REVISIONS DIS-J-001288	DESIGNED RI. SATO	CHECKED TY. OZAKI	DATE 11. 02. 07
APPROVED : KJ. KAWAMURA 05. 08. 25				DRAWING NO. EDC4-180547-00			
CHECKED : TY. OZAKI 05. 08. 25				PART NO. MS-162-C(LP)-1			
DESIGNED : YH. MATSUO 05. 08. 24				CODE NO. CL358-0222-4-00			
DRAWN : YH. MATSUO 05. 08. 24				1/1			