

4

3

2

1

THIS DRAWING IS UNPUBLISHED. RELEASED FOR PUBLICATION
 © COPYRIGHT - BY TYCO ELECTRONICS CORPORATION. ALL RIGHTS RESERVED.

LOC DIST
 AJ 00

REVISIONS

P	LTR	DESCRIPTION	DATE	DWN	APVD
G1		REVISED PER ECO-06-018704	06SEP2006	MC	JH
G2		REV PER ECO-09-021510	04SEP09	KK	AEG

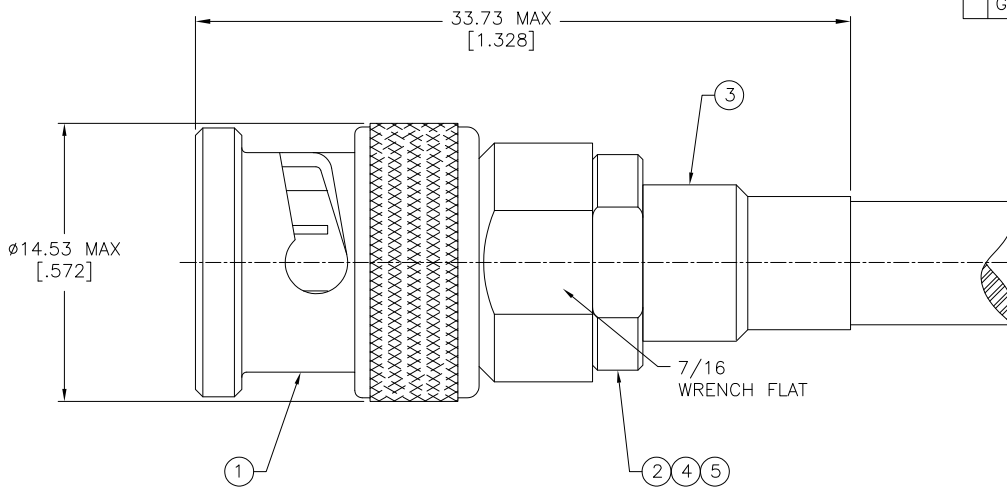

NOTES:

- USE CRIMPING TOOL 69667.
- SEE INSTRUCTION SHEET 408-2055.
- PARTS PACKAGED SEPARATELY.
- OBsolete PARTS: OBSOLETE CIS STREAMLINING PER D.RENAUD/D.SINISI

△	OBsolete	ROLM 49D2401 TWINAX	332214	332222-1	9-332224-0	1-332221-5	5-330949-0	332225-6
		RG 108/U & 108A/U	332214	332222-1	9-332224-0	1-332221-4	5-330949-0	332225-5
	OBsolete	TROMPETER TWC-124-2	332214	332222	1-332224-0	1-332221-3	2-330949-2	332225-3
		RG 108/U & 108A/U	332214	332222	1-332224-0	332221	2-330949-2	332225
		FOR USE WITH CABLE	⑤ SEAL QTY=1	④ DIELECTRIC QTY=1	③ FERRULE QTY=1	② CRIMP END QTY=1	① PLUG ASSY QTY=1	PART #

THIS DRAWING IS A CONTROLLED DOCUMENT.

DWN G. VIERA 10JUL03		Tyco Electronics Corporation Harrisburg, PA 17105-3608	
CHK J. HAVENER 10JUL03	NAME		
APVD J. HAVENER 10JUL03	PLUG, TWIN BNC		
PRODUCT SPEC	SIZE	CAGE CODE	DRAWING NO
APPLICATION SPEC	A3	00779	C-332225
WEIGHT 0.50 OZ.	CUSTOMER DRAWING		RESTRICTED TO
SCALE 5:1		SHEET 1 OF 1	REV G2

DIMENSIONS:	TOLERANCES UNLESS OTHERWISE SPECIFIED:
MM	
0 PLC	± .
1 PLC	± .
2 PLC	± .
3 PLC	± .
4 PLC	± .
ANGLES	± 1°

MATERIAL	FINISH
-	-