

LOC	DIST	REVISIONS					
DF	X5	P	LTR	DESCRIPTION	DATE	DWN	APVD
		J		ECO-06-003170	10MAR06	PY	WM

1. PARTS PACKAGED UNASSEMBLED
2. SEE I.S. 1771
3. FOR USE WITH 22 AWG MAX CABLE
4. .125 MAX PANEL THICKNESS
5. WEIGHT = .062 OZ

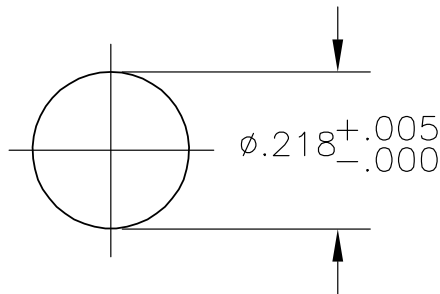

SUGGESTED PANEL CUTOUT FOR -2 ASSY

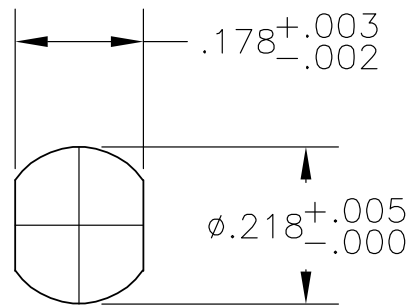

SUGGESTED PANEL CUTOUT FOR 329852 (NO DASH NO.) AND 5-0 ASSYS

5-328691-0	5-328690-0	5-330308-0	5-329852-0
1-328691-2	1-328690-2	222073-1	329852-2
328691	328690	330308	329852
③ WASHER LOCK QTY = 1	② NUT JAM QTY = 1	① SOLDER RCPT ASSY QTY = 1	PART NO

RELEASED FOR PUBLICATION

ALL RIGHTS RESERVED.

THIS DRAWING IS UNPUBLISHED. © COPYRIGHT BY TYCO ELECTRONICS CORPORATION.

DIMENSIONS: INCHES	DWN	26JAN01	MATERIAL	-	FINISH	-
	CHK	26JAN01	Tyco Electronics Corporation Harrisburg, Pa 17105-3608			
TOLERANCES UNLESS OTHERWISE SPECIFIED:	APVD	26JAN01				
0 PLC ± -	PRODUCT SPEC		NAME			
1 PLC ± -	108-12013		CONNECTOR, COAXIAL, RF			
2 PLC ± -	APPLICATION SPEC		RCPT, SOLDER SERIES, MINIATURE THD			
3 PLC ± -	-		SIZE	CAGE CODE	DRAWING NO	RESTRICTED TO
4 PLC ± -	WEIGHT		A4	00779	③-329852	-
ANGLES ± -	-		CUSTOMER DRAWING			SCALE
						1:1
						SHEET
						1 OF 1
						REV
						J