

DRAWING MADE IN THIRD ANGLE PROJECTION
 THIS DRAWING IS UNPUBLISHED. RELEASED FOR PUBLICATION
 © COPYRIGHT 19 BY AMP INCORPORATED. ALL INTERNATIONAL RIGHTS RESERVED.

LOC		DIST		REVISIONS			
P	F	ZONE	LTR	DESCRIPTION	DATE	APPD	
			L	OBSOLETE -22 PER 0E10-0130-99	130E099	MO	

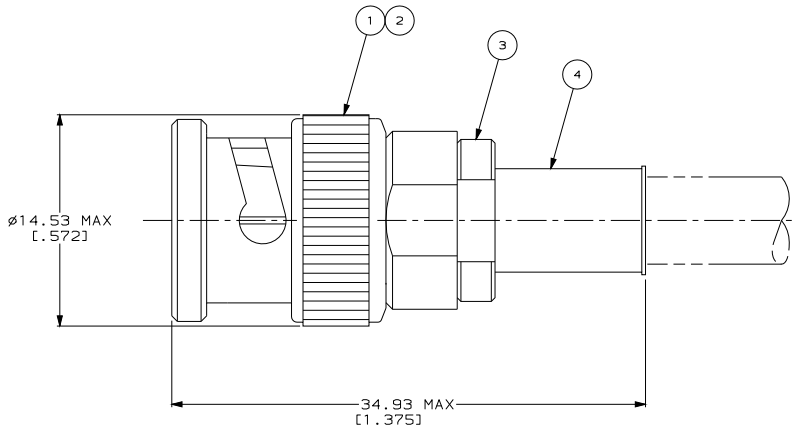

⚠ FOR CABLE: RG-59/U, 59A/U, 59B/U, 62/U, 62A/U, 62B/U, 124/U, 140/U, 210/U
 2. USE INSTRUCTION SHEET 1799-1

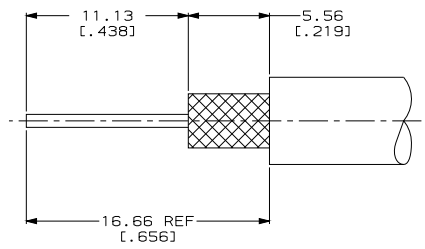

RECOMMENDED STRIP LENGTH
 NO SCALE

OBSOLETE	-	-	-	-	-	-	-	7-329445-2
OBSOLETE	-	-	-	-	-	-	-	7-329445-1
OBSOLETE	RG-71/U, 71A/U, 71B/U	69141-2	329460	50780-3	2-329106-1	329804	-	2-329445-2
	⚠	69141-1	329041	50780-3	2-329106-1	329804	-	2-329445-1
SUPERSEDED BY 2-329445-1	-	-	-	-	-	-	-	329445
	CABLE	CRIMP TOOL	④ FERRULE QTY=1	③ CRIMP END ASSEMBLY QTY=1	② GASKET QTY=1	① PLUG ASSEMBLY QTY=1		PART NUMBER

DO NOT SCALE PRINT. UNLESS SPECIFIED DIMENSIONS IN mm [INCHES] TOLERANCES ON : 2 PLC DEC ± 0.41 [0.016] 3 PLC DEC ± - ANGLES ± -		DR 14FEB96 MICHAEL E. COWHER	AMP Incorporated Harrisburg, PA 17105-3608	
MATERIAL		CHK 15FEB96 FRANK P. MORANA	NAME	
FINISH		APPD 15FEB96 FRANK P. MORANA	PLUG, BNC	
APPLICATION SPEC		APPD 15FEB96 MICHAEL E. COWHER	SIZE C	CAGE CODE 00779
WEIGHT		PRODUCT SPEC	DRAWING NO 329445	DRAWING NO 329445
		SCALE 5:1	SHEET 1 OF 1	

CUSTOMER DRAWING

329445

A