

4

3

2

1

THIS DRAWING IS UNPUBLISHED. RELEASED FOR PUBLICATION  
 © COPYRIGHT 19 BY AMP INCORPORATED. ALL RIGHTS RESERVED.

Loc	Dist	REVISIONS			
P	LTR	DESCRIPTION	DATE	DWN	APVD
	G	REDWN AND REV PER EC 0220-0720-95	15FE896	MEC	FPM
	H	REVISED PER 0503-0155-96	12-9-96	JG	FM

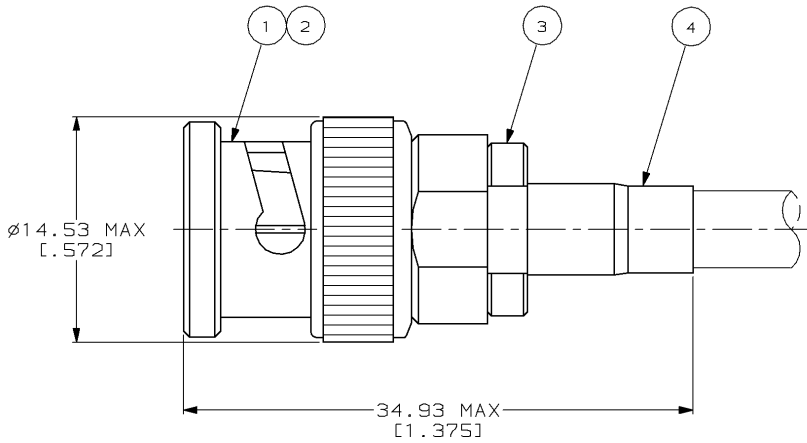

1. USE INSTRUCTION SHEET 1799-1
2. USE CRIMP TOOL 69140-1 WITH CABLE RG-58/U, 58A/U, 58B/U, 58C/U
3. USE CRIMP TOOL 69140-2 WITH CABLE RG-55/U, 55A/U, 55B/U AND 223/U

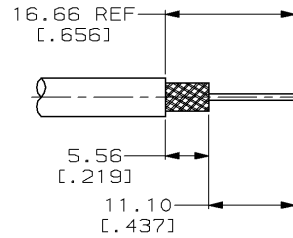

RECOMMENDED STRIP LENGTH  
SCALE 2:1

OBSELETE	-	-	-	-	7-329444-1
3	329099	50780-1	2-329106-1	329804	2-329444-2
3	328663	50780-1	2-329106-1	329804	2-329444-1
SUPERSEDED BY 2-329444-1					
4	FERRULE QTY=1	3	CRIMP END ASSEMBLY QTY=1	2	GASKET QTY=1
				1	PLUG ASSEMBLY QTY=1
					PART NUMBER

THIS DRAWING IS A CONTROLLED DOCUMENT.

DIMENSIONS: mm (INCHES)	TOLERANCES UNLESS OTHERWISE SPECIFIED:	DWN MICHAEL E. COWHER 15FE896	AMP Incorporated Harrisburg, PA 17105-3608
0 PLC ±-	1 PLC ±-	CHK FRANK P. MORANA 15FE896	PLUG, BNC
2 PLC ±0.41 (1.016)	3 PLC ±-	APVD FRANK P. MORANA 15FE896	
MATERIAL	FINISH	PRODUCT SPEC	SIZE A3
		APPLICATION SPEC	CAGE CODE 00779
		WEIGHT	DRAWING NO C-329444
		CUSTOMER DRAWING	SCALE 4:1
			SHEET 1 OF 1
			REV H