

4

3

2

1

THIS DRAWING IS UNPUBLISHED.
 © COPYRIGHT 19 BY AMP INCORPORATED. ALL RIGHTS RESERVED.

REVOLUTIONS		DATE	BY	APP'D
H	REDWN & REV PER 0220-0263-94	16/MAY/94	BMW	JM
J	REV PER 0220-0401-94	05/OCT/94	JPD	JM
K	REV PER 0220-0339-96	18/JAN/96	BM	JC
L	REVISED PER 0030-0001-98	2-25-98	JG	BM
M	REV PER EC 0514-0453-04	17OCT05	TS	GM

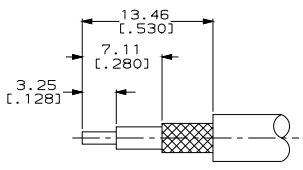

RECOMMENDED STRIP LENGTHS
SCALE NTS

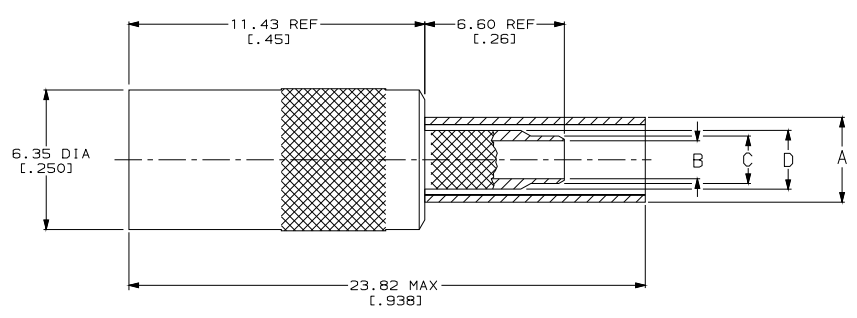

- MATERIALS:
 BODY...BRASS PER QQ-B-626
 INNER AND OUTER CONTACTS...
 BERYLLIUM COPPER PER QQ-C-533
 DIELECTRIC...TEFLON PER LP-403
- FINISH:
 BODY,CENTER AND OUTER CONTACTS...
 GOLD PER MIL-G-45204 OVER
 NICKEL PER QQ-N-290
- FINISH:
 BODY...NICKEL PER QQ-N-290 OVER
 COPPER PER MIL-C-14550
 CENTER AND OUTER CONTACTS...
 GOLD PER MIL-G-45204 OVER
 NICKEL PER QQ-N-290
- FINISH:
 BODY AND OUTER CONTACT...NICKEL
 PER QQ-N-290 OVER COPPER PER
 MIL-C-14550
 CENTER CONTACT...GOLD PER
 MIL-G-45204 OVER NICKEL PER
 QQ-N-290
- INTERFACE PER MIL-C-39012
- SEE I.S. SHEET 2987-12

POSITION LETTER	AMP DIE SET	HEX SIZE	DANIELS DIE SET	SELECTOR NUMBER	DANIELS POSITIONER	D DIA	C DIA	B DIA	A DIA	NOTES	CABLE	PART NO
B	58483-1	.128	HX4-1637	4	K699	2.64 [.104]	2.16 [.085]	1.70 [.067]	3.86 [.152]	△	RG 179,161,187	1-413985-2
B	58483-1	.128	HX4-1637	4	K699	2.64 [.104]	2.16 [.085]	1.70 [.067]	3.86 [.152]	△	RG 179,161,187	1-413985-1
B	58483-1	.128	HX4-1637	4	K699	2.64 [.104]	2.16 [.085]	1.70 [.067]	3.86 [.152]	△	RG 179,161,187	1-413985-0
A	58483-1	.105	HX4-1637	4	K699	1.98 [.076]	1.37 [.055]	0.96 [.040]	3.86 [.152]	△	RG 178,196	413985-9
C	58483-1	.151	HX4-1637	4	K699	2.64 [.104]	2.16 [.085]	1.70 [.067]	4.54 [.179]	△	RG 174,188,316 (ALL DBL SHIELDED)	413985-8
B	58483-1	.128	HX4-1637	4	K699	2.64 [.104]	2.16 [.085]	1.70 [.067]	3.86 [.152]	△	RG 174,188,316	413985-7
A	58483-1	.105	HX4-1637	4	K699	1.98 [.076]	1.37 [.055]	0.96 [.040]	3.86 [.152]	△	RG 178,196	413985-6
A	58483-1	.105	HX4-1637	4	K699	1.98 [.076]	1.37 [.055]	0.96 [.040]	3.86 [.152]	△	RG 178,196	413985-5
C	58483-1	.151	HX4-1637	4	K699	2.64 [.104]	2.16 [.085]	1.70 [.067]	4.54 [.179]	△	RG 174,188,316 (ALL DBL SHIELDED)	413985-4
B	58483-1	.128	HX4-1637	4	K699	2.64 [.104]	2.16 [.085]	1.70 [.067]	3.86 [.152]	△	RG 174,188,316	413985-3
C	58483-1	.151	HX4-1637	4	K699	2.64 [.104]	2.16 [.085]	1.70 [.067]	4.54 [.179]	△	RG 174,188,316 (ALL DBL SHIELDED)	413985-2
B	58483-1	.128	HX4-1637	4	K699	2.64 [.104]	2.16 [.085]	1.70 [.067]	3.86 [.152]	△	RG 174,188,316	413985-1

TOOLING INFORMATION

POSITION LETTER	AMP DIE SET	HEX SIZE	DANIELS DIE SET	SELECTOR NUMBER	DANIELS POSITIONER
	AMP PRO-CRIMPER FOR BRAID CRIMP	M 22520/5-01 FOR BRAID CRIMP	M 22520/2-01 FOR CONTACT CRIMP		

DIMENSIONS IN (INCHES)	TOLERANCES UNLESS OTHERWISE SPECIFIED: .010 ± .005 .015 ± .005 .020 ± .005 .030 ± .005 .040 ± .005 .050 ± .005 .060 ± .005 .070 ± .005 .080 ± .005 .090 ± .005 .100 ± .005	DATE: 16/MAY/94 BY: WERNER DATE: 16/MAY/94 BY: McLEOD DATE: 16/MAY/94 BY: McLEOD	AMP AMP Incorporated Harrisburg, PA 17105-3608 PLUG, STR CABLE, HEX CRIMP, OUTER FERRULE, CRIMP OR SOLDER CENTER CONTACT, SMB SIZE: A2 CAGE CODE: 00779 DRAWING NO: C-413985 SCALE: 8:1 SHEET: 1 OF 1 REV: M
---------------------------	---	---	---

413985

B

A