

- △ USE WITH PRO-CRIMPER 354940-1.
- 2. MAXIMUM PANEL THICKNESS: 6.10 [.240]
- 3. SEE INSTRUCTION SHEET 408-9051

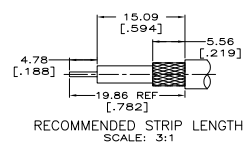
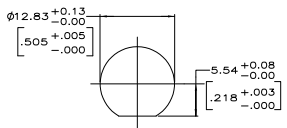
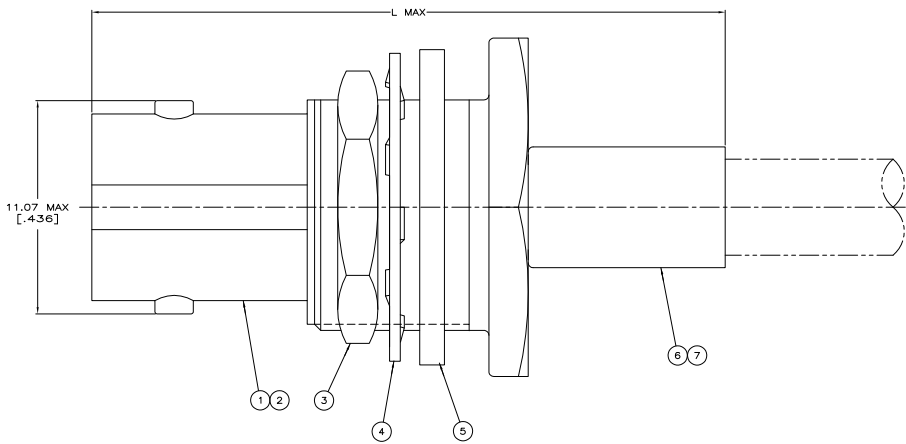

RG-174/U, 188/U, 316/U	34.93 [1.375]	220210-1	220009-5	21427-4	9-328666-0	329633	1-329632-2	1-329631-2	2-221149-0	227461-1	5228980-7
RG-59/U, 59A/U, 59B/U, 62/U, 62A/U, 62B/U	34.93 [1.375]	220189-2	220187-2	-	9-50428-0	329633	1-329632-2	1-329631-2	1-221149-3	227461-3	5228980-6
RG-58/U, 58A/U, 58B/U, 58C/U, 141/U, 141A/U	34.93 [1.375]	220189-1	220187-1	-	9-50427-1	329633	1-329632-2	1-329631-2	221149-6	227461-2	5228980-5

FOR USE WITH CABLE	L	DIE SET △	CRIMP TOOLING	⑦ BUSHING QTY=1	⑥ FERRULE QTY=1	⑤ GASKET QTY=1	④ LOCKWASHER QTY=1	③ JAM NUT QTY=1	② CONTACT QTY=1	① JACK ASSEMBLY QTY=1	PART NUMBER
--------------------	---	-----------	---------------	--------------------	--------------------	-------------------	-----------------------	--------------------	--------------------	--------------------------	-------------

THIS DRAWING IS A CONTROLLED DOCUMENT.

REVISIONS: 100-12047

DATE: 04/19/98

SCALE: 10:1

CUSTOMER DRAWING

5228980

100779

5228980

10-1

1 of 1

REV A