

4

3

2

1

THIS DRAWING IS UNPUBLISHED. RELEASED FOR PUBLICATION NOV. 2006.
 © COPYRIGHT 2006 BY TYCO ELECTRONICS CORPORATION. ALL RIGHTS RESERVED.

LOC	DIST	REVISIONS			
P	LTR	DESCRIPTION	DATE	DWN	APVD
	B	REVISED PER ECO-09-003420	14FEB09	ANS	BOB

NOTES

- 1 SINGLE PACK IN ACCORDANCE WITH AMP SPEC 107-3275
- 2 100 TRAY PACK IN ACCORDANCE WITH AMP SPEC 107-3275
- 3 Ni PLATING
- 4. FOR TECHNICAL DATA REFER TO YOUR LOCAL TYCO ELECTRONICS SALES OFFICE
- 5. ALL DIMENSIONS ARE NOMINAL FOR REFERENCE ONLY UNLESS OTHERWISE STATED

THREAD X	A	CABLE GROUPS	PART NO.
M8	5.60	CT125	5-1814822-7
M8	5.60	CT125	5-1814822-6
M7	4.90	CT100	5-1814822-5
M7	4.90	CT100	5-1814822-4
M9	4.90	RG6/U	5-1814822-3
M9	4.90	RG6/U	5-1814822-2
1/4-20UNC-2B	3.90	RG59B/U, 62A/U, 140/U, 210/U, URM90, Belden 9291, 9291, KX6A, KX25, KX52, KX53	5-1814822-1
1/4-20UNC-2B	3.90	RG59B/U, 62A/U, 140/U, 210/U, URM90, Belden 9291, 9291, KX6A, KX25, KX52, KX53	5-1814822-0

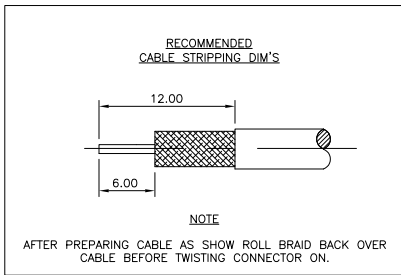
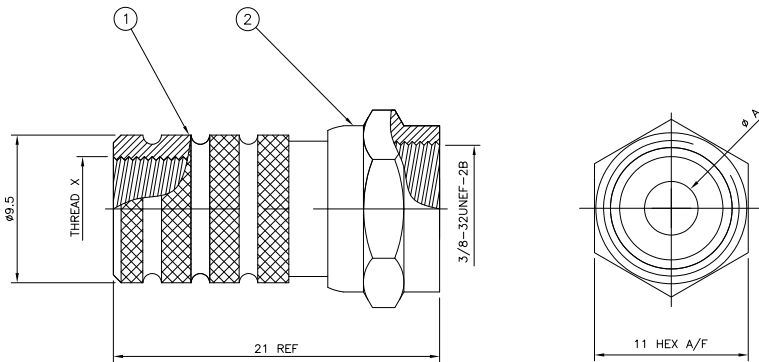

QUANTITY PER ASSY	PARTS LIST
1 1 1 1 1 1 1 1	ZINC ALLOY COUPLING NUT 2
1 1 1 1 1 1 1 1	BRASS BODY 1
5-75-65-35-45-35-25-15-0	MATERIAL DESCRIPTION ITEM

THIS DRAWING IS A CONTROLLED DOCUMENT.

DIMENSIONS: mm	TOLERANCES UNLESS OTHERWISE SPECIFIED:	DWN ANSON MA 14FEB09	CHK RITA ZUO 14FEB09	APVD BOB ZHAO 14FEB09	NAME	Tyco Electronics Corporation Kunshan, Jiangsu, China, 215312
0 PLC ± -	1 PLC ± 0.3	PRODUCT SPEC	F TYPE STR PLG T/O			
2 PLC ± 0.2	3 PLC ± 0.1	APPLICATION SPEC	108-112000			
4 PLC ± -	ANGLES ± 5'	WEIGHT	SIZE A3	CAGE CODE 00779	DRAWING NO C-1814822	
MATERIAL SEE TABLE	FINISH	CUSTOMER DRAWING	SCALE NTS	SHEET 1 OF 1	REV B	