

DRAWING MADE IN THIRD ANGLE PROJECTION
 THIS DRAWING IS UNPUBLISHED. RELEASED FOR PUBLICATION
 © COPYRIGHT 19 BY AMP INCORPORATED. ALL INTERNATIONAL RIGHTS RESERVED.

REVISIONS						DATE	APPD
MOD	LOC	DIST	P	F	ZONE	DESCRIPTION	
4	BD	35				REDRAWN W/O CHANGE PER EC 0020-569-94	05/01/94

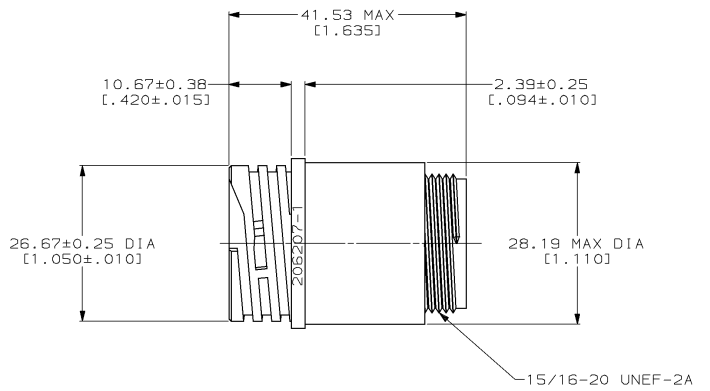
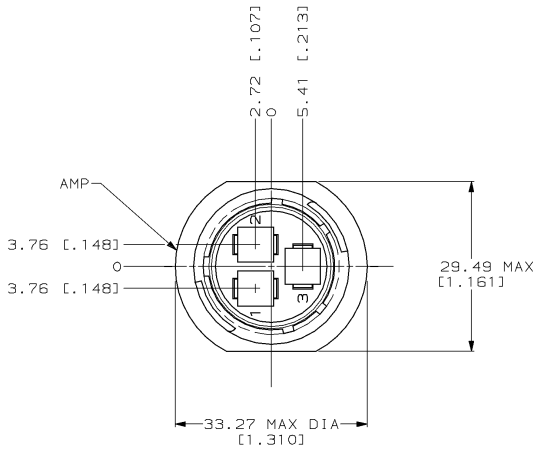

1. CAVITY IDENTIFICATION ON FRONT AND REAR FACE.
2. WILL ACCEPT THREE (3) TYPE XII PIN CONTACTS.

THIS DRAWING IS A CONTROLLED DOCUMENT FOR AMP INCORPORATED. IT IS SUBJECT TO CHANGE AND THE CONTROLLING ENGINEERING ORGANIZATION SHOULD BE CONTACTED FOR THE LATEST REVISION.

DO NOT SCALE PRINT. UNLESS SPECIFIED DIMENSIONS IN mm [INCHES] TOLERANCES ON : 2 PLC DEC ±0.13 [0.005] 3 PLC DEC ± - ANGLES ± -		DR 06/01/94 D.HARDY	PART NO 206207-1	
MATERIAL NYLON, BLACK	APPD 07/13/94 A.FRANTUM	CHK 05/08/94 W.G.LENKER	AMP AMP Incorporated Harrisburg, PA 17105-3608	
FINISH -	PRODUCT SPEC -	APPD 07/13/94 A.FRANTUM		
APPLICATION SPEC -	SCALE 2:1	NAME RCPT HSG, STANDARD SEX, SHELL SIZE 17, CPC	SIZE C 00779	DRAWING NO C=206207
WEIGHT -	SCALE 2:1	CAGE CODE 00779	SHEET 1 OF 1	CUSTOMER DRAWING

206207

A