

THIS DRAWING IS UNCLASSIFIED
 RELEASED FOR PUBLICATION
 24-JUL-2001
 BY: TICO ELECTRONICS CORPORATION ALL RIGHTS RESERVED.
 COPYRIGHT 2001 BY TICO ELECTRONICS CORPORATION. ALLE RECHTE VORBEHALTEN.

LOC	DIST	REVISIONS					
A1	-	P	LTR	DESCRIPTION	DATE	DWN	APVD
PROJEKT NR. EGIPC01017		A1		EG00-1033-01	29MAR2001	NG	GF
		A2		NOTES FOR HAND-TOOLS ADDED	10SEP2002	NG	GF

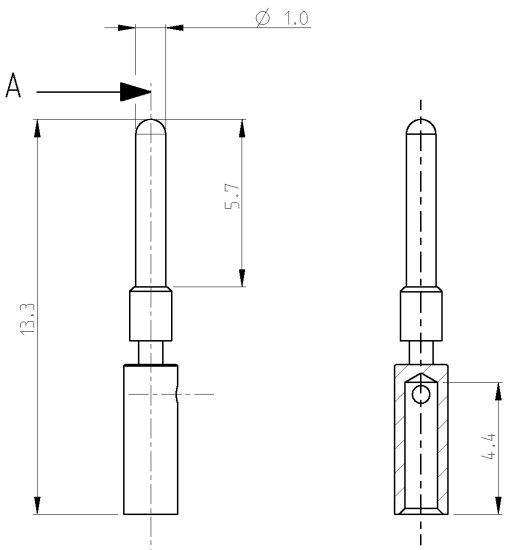

- MATERIAL: BRASS
MATERIAL: MESSING
 - PLATING: TRIBOR 4 µm
BESCHICHTUNG: TRIBOR 4 µm
- ⚠ MATING HAND-CRIMPING-TOOL SEE PN 601966-1
 USED WITH POSITIONER PN 1579003-1
 PASSENDE HANDZANGE SIEHE PN 601966-1
 IN VERBINDUNG MIT POSITIONIERER PN 1579003-1

	CONNECTING CROSS-SECTION ANSCHLUSSQUERSCHNITT	SET-NO. ON HAND-CRIMPING TOOL HANDZANGENPOSITION	
5-1437720-4	0.5mm ²	6	-
5-1437720-5	0.25mm ²	-	5
5-1437720-5	0.14mm ²	-	5

ORDER QUANTITY/ BESTELLMENGE	300 PIECES/STUECK	500 PIECES/STUECK
CATALOG-NO./ KATALOG-NR.	T01-CRIMP-P03	T01-CRIMP-P05
TYCO-NO./ TYCO-NR.	5-1437720-4	5-1437720-5

<small>THIS DRAWING IS A CONTROLLED DOCUMENT FOR TICO ELECTRONICS CORPORATION IT IS SUBJECT TO CHANGE AND THE CONTROLLED ENGINEERING ORGANIZATION SHOULD BE CONTACTED FOR THE LATEST REVISION. DIESER ZEICHNUNGSDOKUMENT IST EIN KONTROLLIERTES DOKUMENT ANDERUNGEN, DIE DEN TECHNISCHEN FORTSCHRITT BEEINFLUSSEN, SIND VORZUGLICH DER ZUSAMMENARBEITENDE ANWANDERUNGSPARTNER ZU VERMIDELN.</small>		OWN: N. GEISTER 29MAR2001 CHK: H. SCHERER 29MAR2001 APVD: G. FEILDMAYER 29MAR2001	tyco Electronics tyco Electronics AMP GmbH D - 64625 Bensheim
DIMENSIONS: MASSTÄBEN: (MM)	TOLERANCES UNLESS OTHERWISE SPECIFIED: ALLGEMEINER TOLERANZEN	PRODUCT SPEC Produktspez.	NAME: T01 CRIMP CONTACT MALE T01 CRIMP KONTAKT STIFT
	0 PLC ±0.10 IN 7168 m 1 PLC ± 2 PLC ± 3 PLC ± 4 PLC ± ANGLES IN DEGREE ±1° FINISH/OBERFLÄCHE/FARBE -	APPLICATION SPEC Verarbeitungspez.	
MATERIAL -		WEIGHT Gewicht	RESTRICTED TO NUR FÜR
AMP 1470-19 REV 31MAR2000		SIZE: A3 CAGE CODE: 00779 DRAWING NO. / ZEICHNUNGS-NR.: 5-1437720-4	SCALE: - SHEET: 1 OF 1 REV: A2