

MIL-DTL-38999 series III and range extension

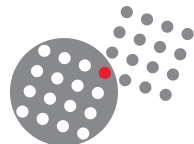

SOURIAU
Connection Technology



SOURIAU

Connectors and interconnect systems for harsh environments

The company designs, manufactures and markets high performance interconnect solutions for severe environments from industrial broadband and universal ranges to complex system with integrated functions: filtering, high speed data transmission, hermetic seal, separation mechanism, remote handling, underwater mating, ...

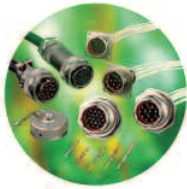

Industrial



Aeronautical



Equipment & system

The dedicated end markets for SOURIAU's products are aeronautical, defense-space and industrial.



Railway
Geophysics
Manufacturing environment
Instrumentation
Automation & process



Civil & military aircraft
Helicopter
Weapon delivery system
Avionics



Military marine
Communications
Satellites
Launcher & missile

SOURIAU was established in 1917 and has been created by successive acquisitions of the industrial, aeronautical, defense and space activities of SOURIAU, JUPITER and BURNDY.

The Group's products are engineered and manufactured in the USA and Dominican Republic, Europe and Morocco, Japan and India, and sold by a worldwide sales and marketing organization, and in addition to SOURIAU's offices, a large network of licensed distributors and agents.

SOURIAU complies with most of national and international Quality Assurance Standards, production unit with ISO 14001.

**Quality Certificate
Management System**

ISO 9001

**Environment Certificate
Management System**

ISO 14001

**Quality Certificate
Management System**

Aeronautic Industry : EN 9100

MIL-DTL 38999 Series III



Introduction

This product family is in accordance with MIL-DTL-38999 K Serie III , EN 3645 and CECC standard for bronze shell

Proposed in aluminium, composite, stainless steel, titanium and bronze versions.

This family gives :

- A high contact density up to 128 contacts #22D.
- A quick screw coupling with self locking mechanism.
- 100% scoop proof offering polarising options by angular positioning of keys.
- EMI enhanced protection by shielding ring and shell to shell bottoming.

Moreover, composite connectors reach high performance in terms of:

- Resistance to salt spray (> 2000 hours)
- Endurance : (> 1500 mating / Unmating operations with specific contacts)

Its choice is recommended wherever weight is critical (typically –30% versus aluminium version) or particularly in harsh climatic and mechanical environments.

8D Titanium version is characterized by a very high and mechanical resistance:

- Weight saving as compared to stainless steel
- Unplated and nickel plated version available

8D / D38999 family has applications in:

- Aeronautics and military
- Marine and offshore
- Industrial.

For more informations or questions, please contact us to:

Contactmilaero@souriau.com

MIL-DTL 38999 Series III



Summary

Company profile	2
Introduction	3
Overview	5
Technical characteristics	6
Layouts	8
8D - D38999 Aluminium Series	13
8D - D38999 Composite Series	25
8D - D38999 Stainless Steel	33
8D Titanium Series	39
JVS Bronze Series	47
Common section (contacts, orientation, panel cut-out, tools...)	57
8D - JVS Series with quadrax contacts	67
8D - JVS with optical Elio contacts	75
8D reinforced sealing Series	83
F38999 Hermetic	85
8D Series with RJ45 USB	89
Coordinates for PCB	100

MIL-DTL 38999 Series III



Overview

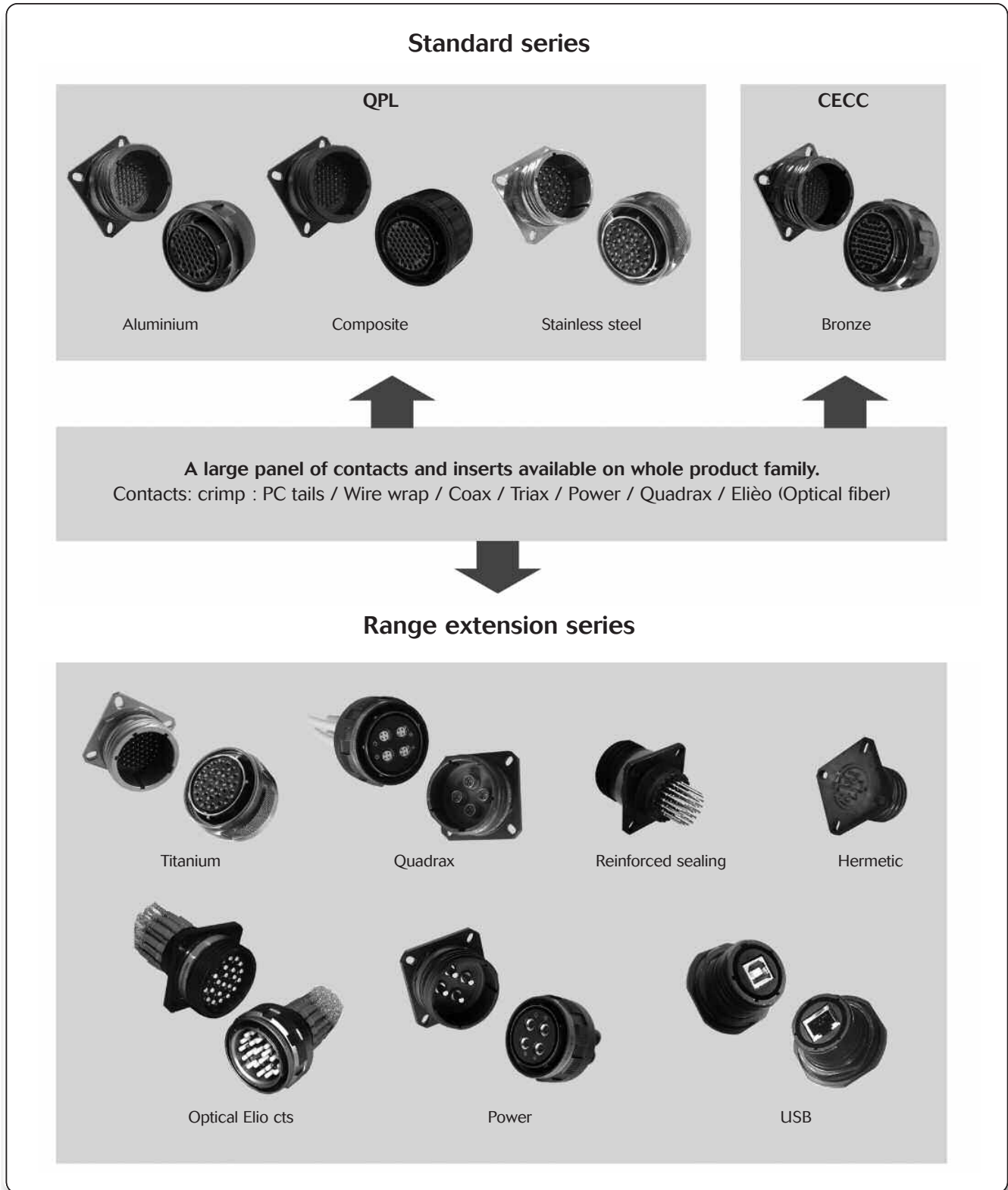

MIL-DTL 38999 Series III



Technical characteristics

Characteristics

• **Shell:**
Aluminium, composite, stainless steel, bronze

• **Shells plating:**

Aluminium shell:
Cadmium olive drab (W)
Nickel (F)
Black zinc nickel (Z)
Green zinc cobalt (ZO)

Composite shell:
Cadmium olive drab (J)
Nickel (M)
Without plating (X)

Stainless steel shell:
Passivated (K)
Nickel (S)

Titanium shell:
Without plating (TT)
Nickel (TF)

Boitier bronze:
Without plating

• **Insulator:** Thermoplastic or thermoset.

• **Grommet and interfacial seal:**
Silicone elastomer

• **Contacts:** Copper alloy

• **Contacts plating:** Gold over nickel plated

• **Endurance:**
- 500 mating / unmating operations whatever the material used
- 1500 mating / unmating operations with composite connectors + specifics contacts

• **Shock:**
300g, 3 ms according EN 2591-D2 method A

• **Vibration:**
Sinus:
10 à 2000 Hz, 3x12 hrs (60g, 140 – 2000 Hz) with temperature cycling

Random:
- 50 to 2000 Hz, 2x8 Hrs (1g²/ Hz, 100 – 2000Hz) at T° max.
- 25 to 2000 Hz, 2x8 Hrs (5g²/ Hz, 100 – 300Hz) (at ambient T°)

Test with accessories in acc with EN 2591-D3

• **Contacts retention:**

Contacts size	22	20	16	12	8	4
Min force in N	44	67	111	111	111	200

Weight comparison

Example for a plug shell size 15

Materials	Weight
Stainless steel	58.80 grs
Titanium	33.90 grs
Aluminium	20.35 grs
Composite	14.30 grs

40% lighter (Aluminium vs Stainless steel)
42% lighter (Composite vs Stainless steel)
30% lighter (Composite vs Titanium)

Electrical

• **Test voltage rating (Vrms):**

Service	At sea level	At 21000 m
M	1 300	800
N	1 000	600
I	1 800	1 000
II	2 300	1 000

For Quadrax see page 70

• **Contact resistance:**

Contacts size	22	20	16	12	8	4
Cts resistance (mΩ)	14.6	7.3	3.8	3.5	3	2

• **Insulation resistance:**
≥ 5 000 MΩ (under 500 Vdc).

• **Contact rating:**

Contacts size	22	20	16	12	8	4
Contact rating (A)	5	7,5	13	23	45	80

• **Shell continuity**

Aluminium shell:
Cadmium olive drab (W): 2.5 mΩ
Nickel (F): 1 mΩ
Black zinc nickel (Z): 2.5 mΩ
Green zinc nickel (ZO): 2.5 mΩ

Composite shell:
Cadmium olive drab (J): 3 mΩ
Nickel (M): 3 mΩ

Stainless steel shell:
Passivated (K) : 10 mΩ
Nickel (S) : 1 mΩ

Titanium shell:
Without plating (TT) : 10 mΩ
Nickel (TF) : 1 mΩ

Bronze shell:
Without plating: 5 mΩ

• **Shielding:**

Aluminium shell:
- 65 db at 10 GHz (F) – 50 db at 10 GHz (W)
- 85 db at 1 GHz (F)
- (Z & ZO): Consult us

Composite shell:
- 90 db at 10 GHz
- 85 db at 1 GHz

Stainless steel shell:
- 45 db at 10 GHz (K)
- 65 db at 10 GHz (S)

Titanium shell:
- 45 db at 10 GHz (TT)
- 65 db at 10 GHz (TF)

Bronze shell: 85 db at 10 GHz

MIL-DTL 38999 Series III



Technical characteristics

Climatics

- **Temperature range:**

- **Aluminium shell:**

- Cadmium olive drab (W): -65°C +175°C
- Nickel (F): -65°C +200°C
- Black zinc nickel (Z): -65°C +200°C
- Green zinc nickel (ZO): -65°C +200°C

- **Composite shell:**

- Cadmium olive drab plating (U): -65°C +175°C
- Nickel (M): -65°C +200°C
- Without plating (X): -65°C +175°C

- **Stainless steel shell:**

- Passivated (K): -65°C +200°C
- Nickel (S): -65°C +200°C

- **Titanium shell:**

- Without plating (TT): -65°C +200°C
- Nickel (TF): -65°C +200°C

- **Bronze shell:**

- No plating: -65°C +175°C

- **Sealing:**

- Mated connectors meet altitude immersion requirements of MIL-DTL-38999.

- **Salt spray:**

- **Aluminium shell:**

- Cadmium olive drab (W): 500 Hrs
- Nickel (F): 48 Hrs
- Black Zinc nickel (Z): 500 Hrs
- Green Zinc cobalt (ZO): 250 Hrs

- **Composite shell:**

- Cadmium olive drab (U) : 2000 Hrs
- Nickel (M): 2000 Hrs
- Without plating (X): 2000 Hrs

- **Stainless steel shell:**

- Passivated (K): 500 Hrs
- Nickel (S): 48 Hrs

- **Titanium shell:**

- Without plating (TT): 500 Hrs
- Nickel (TF): 48 Hrs

- **Bronze shell:**

- No plating: 500 Hrs

Resistance to fluids

- **According to MIL-DTL-38999 standard.**

- Gasoline: JP5 (OTAN F44)
- Mineral hydrolic fluid: MIL-H-5606 (OTAN H515)
- Synthetic hydraulic fluid: Skydrol 500 B4

- **LD4 (SAE AS 1241).**

- Mineral lubricating: MIL-L-7870A (OTAN O142)
- Synthetic lubricating: MIL-L-23699 (OTAN O156), MIL-L-7808.
- Cleaning fluid: MIL-DTL-25769 dilué/diluted
- De-icing fluid: MIL-A-8243.
- Extinguishing fluid: Chlorobrométhane
- Cooling fluid: Coolanol

MIL-DTL 38999 Series III



Contact layouts

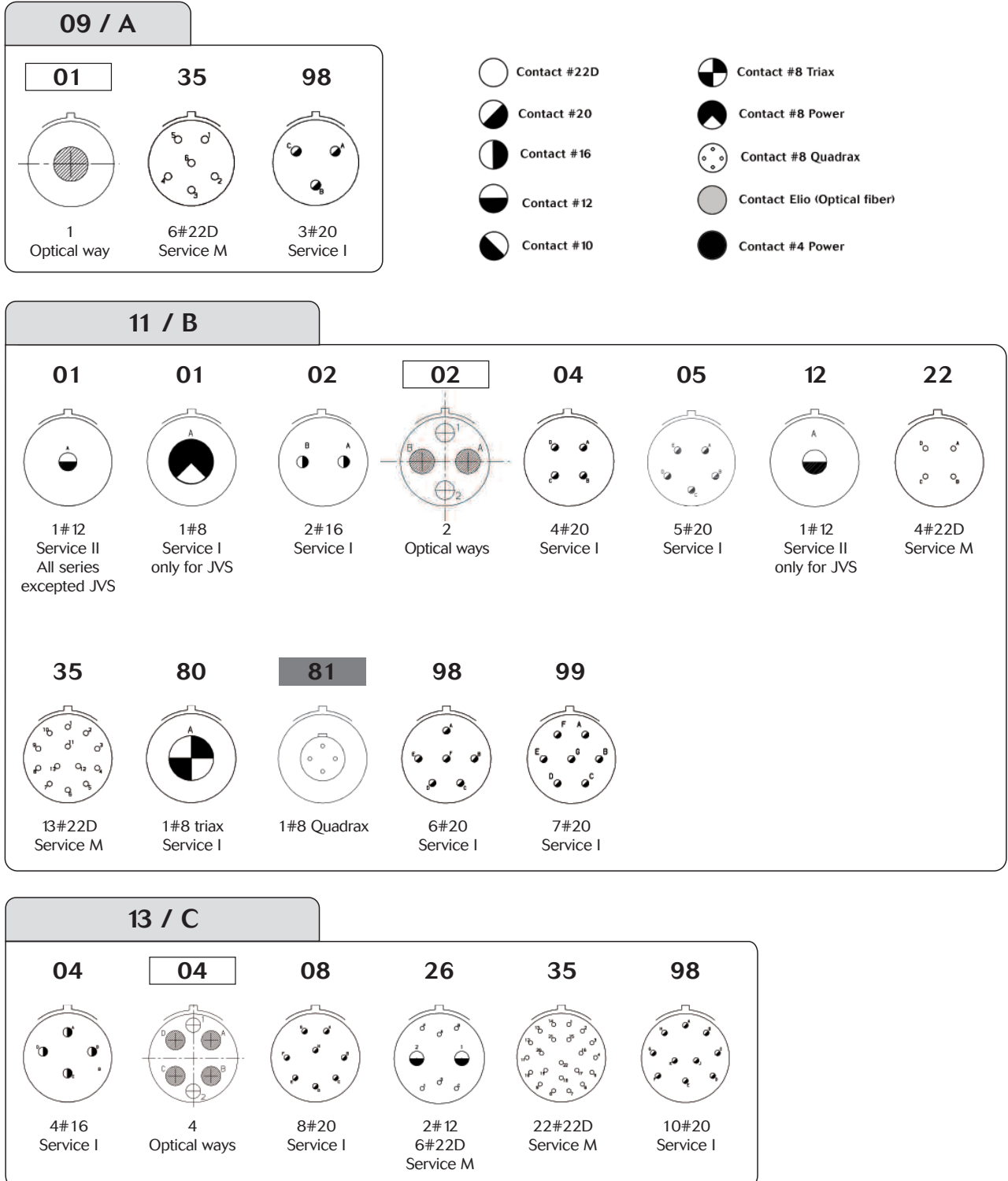

MIL-DTL 38999 Series III



Contact layouts

15 / D

05	15	18	19	35	97
5#16 Service II	1#16 14#20 Service I	18#20 Service I	19#20 Service I	37#22D Service M	4#16 8#20 Service I

17 / E

02	06	08	20	26	35	75	81
38#22D 1#8 triax Service M	6#12 Service I	8#16 Service II	4#12 16#22D Service M	26#20 Service I	55#22D Service M	2#8 triax Service M	38#22D 1#8 Quadrax
82	99						
2 Quadrax	2#16 21#20 Service I						

19 / F

08	11	28	32	35
8 Optical ways	11#16 Service II	26#20 2#16 Service I	32#20 Service I	66#22D Service M

 Elio fiber optics  Ethernet Quadrax

MIL-DTL 38999 Series III



Contact layouts

21 / G

11 11#12 Service I	16 16#16 Service II	35 79#22D Service M	39 2#16 37#20 Service I
41 41#20 Service I	48 4#8 power Service I	75 4#8 triax Service M	84 4 Quadrax

23 / H

21 21#16 Service II	35 100#22D Service M	53 53#20 Service I
54 4#12 9#16 40#22D Service M	55 55#20 Service I	

25 / J

04 8#16 48#20 Service I	07 2#8 triax 97#22D Service M	08 8#8 triax Service M	11 2#20 9#10 Service N	19 19#12 Service I	20⁽¹⁾ 10#20 4#12 coax 13#16 3#8 triax Service N	24 12#16 12#12 Service II	24 24 Optical Ways	29 29#16 Service I
35 128#22D Service M	37 37#16 Service I	41 22#22D 3#20 11#16 2#12 3#8 triax Service M	43 23#20 20#16 Service I	44 4#4 power 4#16 Service I	46 40#20 4#16 2#8 coax Service I	61 61#20 Service I	82 97#22D 2#8 Quadrax	80 10#20 - 4#12 13#16 3#8 Quadrax
81 22#22D - 3#20 11#16 - 2#12 3#8 Quadrax	86 40#20 4#16 2#8 Quadrax	88 8 Quadrax						

(1) For classes F, W, K, S only.

Elio fiber optics
 Ethernet Quadrax

MIL-DTL 38999 Series III



Contact layouts

Shell Size	Layout	Service	MIL - DTL - 38999 (QPL)			8D Titanium	JVS (CECC) Bronze	Hermetics	Number of contacts	#22D	#20	#16	#12	#10	#8	#4 Power	Optical Way
			Alu	Stainless steel	Composite												
09 / A	09 - 01	-						1								1	
	09 - 35	M					x	6	6								
	09 - 98	I					x	3		3							
11 / B	11 - 01	II						1					1				
	11 - 01	II					x	1						1 Coax			
	11 - 02	I					x	2			2						
	11 - 02	-						2								2	
	11 - 04	I						4		4							
	11 - 05	I						5		5							
	11 - 12	I					x	1					1				
	11 - 22	M						4	4								
	11 - 35	M						x	13	13							
	11 - 80	I							1						1 Triax		
	11 - 81	-							1						1 Quadrax		
	11 - 98	I						x	6		6						
11 - 99	I							7		7							
13 / C	13 - 04	I					x	4			4						
	13 - 04	-						4								4	
	13 - 08	I					x	8		8							
	13 - 26	M					x	8	6			2					
	13 - 35	M					x	22	22								
	13 - 98	I					x	10		10							
15 / D	15 - 05	II					x	5			5						
	15 - 15	I					x	15		14	1						
	15 - 18	I					x	18		18							
	15 - 19	I					x	19		19							
	15 - 35	M					x	37	37								
	15 - 97	I					x	12		8	4						
17 / E	17 - 02	M						39	38					1 Triax			
	17 - 06	I					x	6		6							
	17 - 08	II					x	8			8						
	17 - 20	M						20	16			4					
	17 - 26	I					x	26		26							
	17 - 35	M					x	55	55								
	17 - 75	M					x	2						2 Triax			
	17 - 81	-						39	38					1 Quadrax			
	17 - 82	-						2						2 Quadrax			
17 - 99	I					x	23		21	2							
19 / F	19 - 08	-						8								8	
	19 - 11	II					x	11			11						
	19 - 28	I					x	28		26	2						
	19 - 32	I					x	32		32							
	19 - 35	M					x	66	66								
21 / G	21 - 11	I					x	11				11					
	21 - 16	II					x	16			16						
	21 - 35	M					x	79	79								
	21 - 39	I					x	39		37	2						
	21 - 41	I					x	41		41							
	21 - 48	I					x	4						4 Power			
	21 - 59	M						59	55			4		4 Triax			
	21 - 75	-					x	4						4 Quadrax			
21 - 84	-						4										
23 / H	23 - 21	II					x	21			21						
	23 - 35	M					x	100	100								
	23 - 53	I					x	53		53							
	23 - 54	M						53	40		9	4					
	23 - 55	I					x	55		55							
25 / J	25 - 04	I						56		48	8						
	25 - 07	M						99	97					2 Triax			
	25 - 08	-					x ⁽²⁾	8						8 Triax			
	25 - 11	N						11		2			9				
	25 - 19	I					x	19				19					
	25 - 20(1)	N					x	30		10	13	4		3 Triax			
	25 - 24	II					x	24			12	12					
	25 - 24	-						24									24
	25 - 29	I						29			29						
	25 - 35	M					x	128	128								
	25 - 37	I						37			37						
	25 - 41	N						41	22	3	11	2		3 Triax			
	25 - 43	I					x	43		23	20						
	25 - 44	I						8			4						
	25 - 46	I					x	46		40	4			2 Coax		4	
	25 - 61	I					x	61		61							
25 - 80	N						30		10	13	4		3 Quadrax				
25 - 81	N						41	22	3	11	2		3 Quadrax				
25 - 82	M						99	97					2 Quadrax				
25 - 86	I						46		40	4			2 Quadrax				
25 - 88	-						8						8 Quadrax				

(1) For classes F, W, S, K only

(2) For CECC, Layout 25 - 08 only delivery without contact

8D - D38999 Aluminium Series



MIL-DTL 38999 Serie III Aluminium Series



8D - D38999 Aluminum Serie

Connector part numbers

Basic Series	8D	0	-	11	W	35	P	N	**
Shell style:									
0: Square flange receptacle									
1: In line receptacle									
7: Jam nut receptacle									
5: Plug with RFI shielding.									
Type:									
-: Connectors with standard crimp contacts.									
L: Receptacle with long spill (male and female size #22D, #20).									
C: Receptacle with short spill (male and female #22D, #20, #16).									
S: Receptacle with specific spill (male et female #22D)									
W: Receptacle with male contacts #22D for wire wrap (3 wraps)									
T: Receptacle with male contacts #20 for wire wrap (2 wraps)									
Shell size: 09 - 11 - 13 - 15 - 17 - 19 - 21 - 23 - 25									
Plating:									
W: Olive drab cadmium									
F: Nickel									
ZC: Green zinc cobalt									
Z: Black zinc nickel									
Contact layout: See page 8 to 11									
Contact type:									
P: Pin. A: Connector supplied less pin contact or with specific contacts (connector marking: A + orientation).									
S: Socket. B: Connector supplied less socket contact or with specific contacts (connector marking: B + orientation).									
Orientation: N, A, B, C, D & E (see page 58)									
Specification:									
046: Tinned straight spills									
251: Connector provided with power contacts (layouts with contact #8)									
022: Fuel tank									
L: For P or S contact type only, connectors delivered without contacts, connectors marking P or S plus orientation.									

MIL-DTL-38999 part numbers*

Basic Series	D38999	20	W	B	35	P	N	L
Shell style:								
20: Square flange receptacle								
24: Jam nut receptacle								
26: Plug with RFI shielding.								
Plating:								
W: Olive drab cadmium								
F: Nickel								
Shell size: A - B - C - D - E - F - G - H - J								
Contact layout: See page 11 for layout according to MIL-DTL-38999								
Contact type:								
P: Pin. A: Connector supplied less pin contact or with specific contacts (connector marking: A + orientation).								
S: Socket. B: Connector supplied less socket contact or with specific contacts (connector marking: B + orientation).								
Orientation: N, A, B, C, D & E (see page 58)								
L: For P or S contact type only, connector delivered without contacts, connector marking P or S (without L)								

* Note: To place an order of MIL connectors delivered without MIL removable crimp contacts and keep P or S plus orientation marking, it must be specify clearly on the order (by adding a suffix L at the end of the P/N or specified in comment).

8D - D38999 Aluminium Series



Dimensions

Receptacle type 0

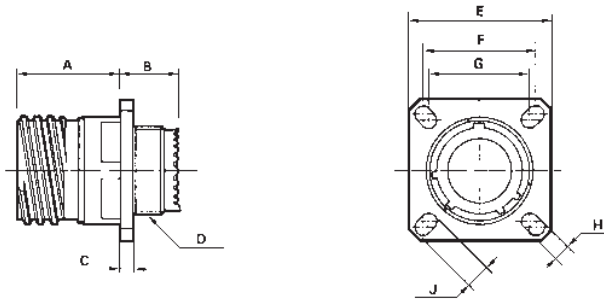

Shell size	A Max.	B Max.	C Max.	D thread	E $\pm 0,30$	F	G	H $\pm 0,20$	J $\pm 0,20$
09 (A)	20.90	10.60	2.50	M12 x 1-6g	23.80	18.26	15.09	3.25	5.49
11 (B)	20.90	10.60	2.50	M15 x 1-6g	26.20	20.62	18.26	3.25	4.93
13 (C)	20.90	10.60	2.50	M18 x 1-6g	28.60	23.01	20.62	3.25	4.93
15 (D)	20.90	10.60	2.50	M22 x 1-6g	31.00	24.61	23.01	3.25	4.93
17 (E)	20.90	10.60	2.50	M25 x 1-6g	33.30	26.97	24.61	3.25	4.93
19 (F)	20.90	10.60	2.50	M28 x 1-6g	36.50	29.36	26.97	3.25	4.93
21 (G)	20.10	11.40	3.20	M31 x 1-6g	39.70	31.75	29.36	3.25	4.93
23 (H)	20.10	11.40	3.20	M34 x 1-6g	42.90	34.93	31.75	3.91	6.15
25 (J)	20.10	11.40	3.20	M37 x 1-6g	46.00	38.10	34.93	3.91	6.15

Receptacle type 7

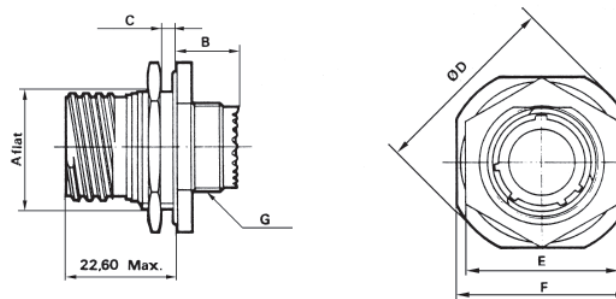

Shell size	A + 0,10 - 0,15	B Max.	C Max.	D Max.	E Max.	F $\pm 0,40$	G thread
09 (A)	16.53	9.90	3.20	30.50	23.00	27.00	M12 x 1-6g
11 (B)	19.07	9.90	3.20	35.20	26.00	31.80	M15 x 1-6g
13 (C)	23.82	9.90	3.20	38.40	31.00	34.90	M18 x 1-6g
15 (D)	26.97	9.90	3.20	41.60	34.00	38.10	M22 x 1-6g
17 (E)	30.15	9.90	3.20	44.80	37.00	41.30	M25 x 1-6g
19 (F)	33.32	9.90	3.50	49.50	41.00	46.00	M28 x 1-6g
21 (G)	36.50	9.90	3.50	52.70	46.00	49.20	M31 x 1-6g
23 (H)	39.67	9.90	3.50	55.90	47.00	52.40	M34 x 1-6g
25 (J)	42.85	9.90	3.50	59.00	52.00	55.60	M37 x 1-6g

8D - D38999 Aluminium Series



In line receptacle type 1

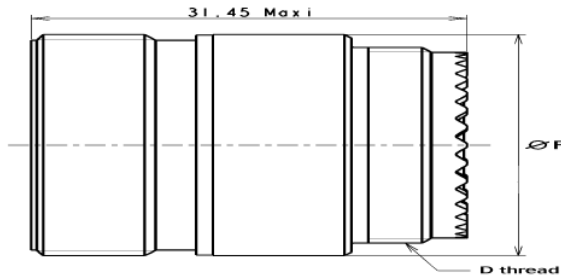

Shell size	D thread	Ø F
09 (A)	M12 x 1-6g	15.90
11 (B)	M15 x 1-6g	19.05
13 (C)	M18 x 1-6g	22.25
15 (D)	M22 x 1-6g	25.40
17 (E)	M25 x 1-6g	30.15
19 (F)	M28 x 1-6g	31.75
21 (G)	M31 x 1-6g	34.75
23 (H)	M34 x 1-6g	37.10
25 (J)	M37 x 1-6g	41.30

Plug type 5

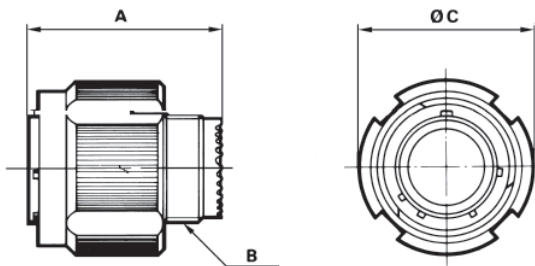

Shell size	A Max.	B thread	C Max.
09 (A)	31.00	M12 x 1-6g	21.80
11 (B)	31.00	M15 x 1-6g	25.00
13 (C)	31.00	M18 x 1-6g	29.40
15 (D)	31.00	M22 x 1-6g	32.50
17 (E)	31.00	M25 x 1-6g	35.70
19 (F)	31.00	M28 x 1-6g	38.50
21 (G)	31.00	M31 x 1-6g	41.70
23 (H)	31.00	M34 x 1-6g	44.90
25 (J)	31.00	M37 x 1-6g	48.00

Maximum coupling torque on panel for jam nut receptacle (type 7)

Shell	09 (A)	11 (B)	13 (C)	15 (D)	17 (E)	19 (F)	21 (G)	23 (H)	25 (J)
Coupling torque (N.m)	6	8	10	13	20	23	25	26	28

Mated connectors dimensions

Type 0 with plug

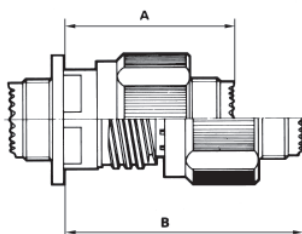

Type 7 with plug

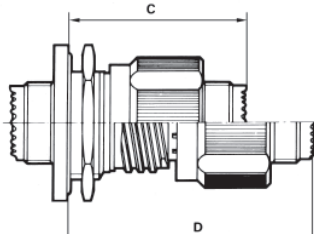

Shell size	A Max.	B Max.	C Max.	D Max.
09 (A)	37.00	52.30	38.30	53.60
11 (B)	37.00	52.30	38.30	53.60
13 (C)	37.00	52.30	38.50	53.80
15 (D)	37.00	52.30	38.50	53.80
17 (E)	37.00	52.30	38.50	53.80
19 (F)	37.00	52.30	38.50	53.80
21 (G)	36.00	51.30	38.50	53.80
23 (H)	36.00	51.30	38.50	53.80
25 (J)	36.00	51.30	38.50	53.80

Dimensions in millimeters

8D - D38999 Aluminium Series



Receptacle with straight spill contacts

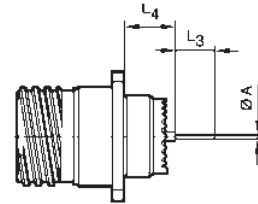
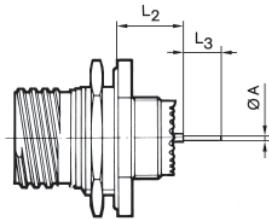

		Shell size			09 (A)	11 (B)	13 (C)	15 (D)	17 (E)	19 (F)	21 (G)	23 (H)	25 (J)
		Contact size	Contact type	Spill type									
A		# 22D	M & F	L & C					0.70				
		# 22D	M & F	S					0.50				
		# 20	M & F	C					0.70				
		# 16	M & F	C					1.15				
L2	Min.	# 22D	M	L & C	10.52					10.34			
	Max.	# 22D	M	L & C	11.46					11.28			
	Min.	# 22D	F	L & C	10.19					10.01			
	Max.	# 22D	F	L & C	11.46					11.28			
	Min.	# 22D	M	S	10.19					10.01			
	Max.	# 22D	M	S	11.46					11.28			
	Min.	# 22D	F	S	10.69					10.51			
	Max.	# 22D	F	S	11.63					11.45			
	Min.	# 20	M	C	10.36					10.18			
	Max.	# 20	M	C	11.63					11.45			
	Min.	# 20	F	C	10.69					10.51			
	Max.	# 20	F	C	11.63					11.45			
	Min.	# 16	M	C	10.69					10.51			
	Max.	# 16	M	C	11.63					11.45			
L3		# 22D	M & F	L					8.50				
		# 22D	M & F	C					4.00				
		# 22D	M & F	S					5.10				
		# 20	M & F	C					5.10				
		# 16	M & F	C					5.10				
L4	Min.	# 22D	M	L & C					9.48				
	Max.	# 22D	M	L & C			10.58					10.69	
	Min.	# 22D	F	L & C			9.15					9.26	
	Max.	# 22D	F	L & C			10.58					10.69	
	Min.	# 22D	M	S			9.65					9.76	
	Max.	# 22D	M	S			10.75					10.86	
	Min.	# 22D	F	S			9.15					9.26	
	Max.	# 22D	F	S			10.75					10.86	
	Min.	# 20	M	C			9.65					9.76	
	Max.	# 20	M	C			10.75					10.86	
	Min.	# 20	F	C			9.65					9.76	
	Max.	# 20	F	C			10.75					10.86	
	Min.	# 16	M	C			9.65					9.76	
	Max.	# 16	M	C			10.75					10.86	
Min.	# 16	F	C			9.65					9.76		
Max.	# 16	F	C			10.75					10.86		

M : Male contact F: Female contact L: Long spill C : Short spill S: Specific spill Dimensions in millimeters

8D - D38999 Aluminium Series



Souriau backshells part numbers

Basic series	8D	102	B	02				
Shell style:								
09	11	13	15	17	19	21	23	25
101	102	103	104	105	106	107	108	109
Plating:								
B: Olive drab cadmium								
F: Nickel								
Backshell type:								
02: Straight cable clamp								
03: 90° cable clamp								
13: Backshell for heat shrink boots								

Cross reference table

Backshell type	AS85049 Standard	SOURIAU part numbers
Straight cable clamp	M85049/38-**-x	8D101x02
90° cable clamp	M85049/39-**-x	8D101x03
Backshell for heat shrink boots	M85049/69-**-x	8D101x13
Backshell for screen termination and cable clamp	M85049/19**x**	N/A

x: Plating **: Shell size (See page 19 to 21)

8D - D38999 Aluminium Series



Standard backshells part numbers

Straight cable clamp (M85049/38)

Basic series M85049 38 - 11 W

Backshell type:
38: Straight cable clamp

Nut type:
-: Without self-locking
S: With self-locking

Shell size:
09 - 11 - 13 - 15 - 17 - 19 - 21 - 23 - 25

Plating (See table 3):
A and W for 38 type
W and N for 38S type

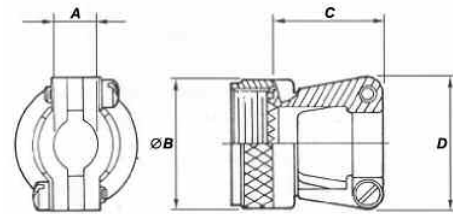

See table 1 for dimensions

90° cable clamp (M85049/39)

Basic series M85049 39 - 11 W

Backshell type:
39: 90° cable clamp

Nut type:
-: Without self-locking
S: With self-locking

Shell size:
09 - 11 - 13 - 15 - 17 - 19 - 21 - 23 - 25

Plating (See table 3):
A and W for 39 type
W and N for 39S type

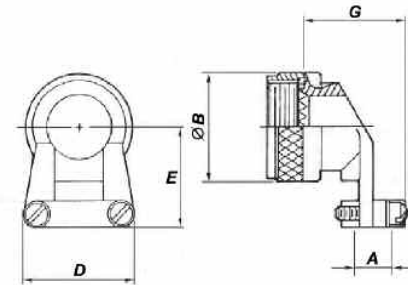

See table 1 for dimensions

Table 1

Shell size	A		ØB Max.	C Max.	D Max.	E	G
	Min	Max.					
09	2.50	5.90	21.80	23.10	21.60	25.40	25.70
11	3.90		25.00		22.90		
13	4.80	8.30	29.40	25.70	27.90	27.90	30.70
15	6.60	11.60	32.50	26.90	29.20	31.80	32.00
17	7.20	15.60	35.70	29.50	33.00	33.00	35.80
19	8.30	16.10	38.50	35.80	38.10	34.30	38.40
21	8.70	17.70	41.70	38.40	40.60	40.60	42.20
23	9.70	20.90	44.90	42.20	43.20	44.50	44.70
25	10.60	21.70	48.00	44.70	45.70	47.00	48.50

Dimensions in millimeters

8D - D38999 Aluminium Series



Backshell for heat shrink boots (M85049/69)

Basic series **M85049** **69** **11** **A** **D**

Backshell type:

69: Straight backshell for heat shrink boot

Shell size:

09 - 11 - 13 - 15 - 17 - 19 - 21 - 23 - 25

Plating:

A: see table 3

Option:

Nothing: Without drain hole
D: With drain hole

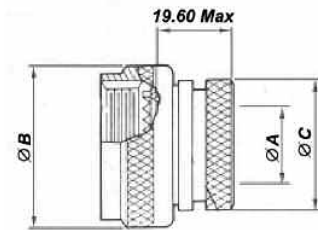

See table 2 for dimensions

Table 2

Shell size	ØB Max.	ØA Max.	ØC Max.
09	19.10	6.35	13.55
11	21.60	9.50	15.40
13	25.40	12.70	19.70
15	29.20	15.90	21.30
17	31.80	19.00	24.50
19	35.60	20.60	26.50
21	39.40	23.80	30.90
23	41.90	27.00	34.40
25	47.00	30.20	36.65

Dimensions in millimeters

Table 3

Plating	Description	Salt spray
A	Black anodise	500 Hrs
N, F	Nickel	48 Hrs
W, B	Olive drab cadmium over nickel	500 Hrs

8D - D38999 Aluminium Series



Backshell for screen termination and cable clamp (M85049/19)

Basic Series

M85049/ 19 11 W 03

Shell style:

19: Backshell for screen termination and cable clamp

Shell size:

09 - 11 - 13 - 15 - 17 - 19 - 21 - 23 - 25

Plating:

W: Olive drab cadmium

N: Nickel

Clamp size indicator:

See table 4 and 5

Table 4

Shell size	A Max.	C Max.	Clamp indicator base on shell size
09		19.10	01 - 02
11		21.60	01 - 0 2 - 03
13		25.40	02 - 03 - 04
15		27.90	02 - 03 - 04 - 05
17	38.10	31.80	02 - 03 - 04 - 05 - 06
19		35.60	03 - 04 - 05 - 06 - 07
21		38.10	03 - 04 - 05 - 06 - 07 - 08
23		41.90	03 - 04 - 05 - 06 - 07 - 09
25		44.50	04 - 05 - 06 - 07 - 08 - 10

Table 5

Clamp size indicator	B		E
	Min.	Max.	
01	1.60	3.20	20.30
02	3.20	6.35	25.40
03	6.35	9.50	27.90
04	7.90	12.70	30.50
05	11.10	15.90	31.80
06	14.30	19.00	35.60
07	17.45	22.20	38.10
08	20.60	24.40	41.90
09	23.80	28.60	44.50
10	27.00	31.75	48.30

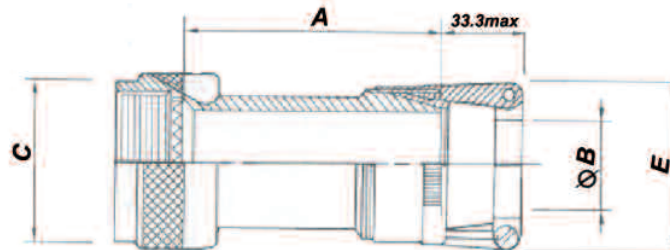

See table 4 & 5 for dimensions

8D - D38999 Aluminium Series



Caps

Caps for receptacle (D38999/33 - S2453)

With stainless steel rope and eyelet

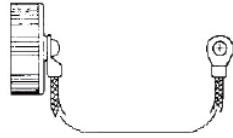

Shell size	Part numbers	
	Plating **	Olive green plating
9	S2453-09W-**	D38999/33 W 09 R
11	S2453-11W-**	D38999/33 W 11 R
13	S2453-13W-**	D38999/33 W 13 R
15	S2453-15W-**	D38999/33 W 15 R
17	S2453-17W-**	D38999/33 W 17 R
19	S2453-19W-**	D38999/33 W 19 R
21	S2453-21W-**	D38999/33 W 21 R
23	S2453-23W-**	D38999/33 W 23 R
25	S2453-25W-**	D38999/33 W 25 R

With stainless steel rope and ring

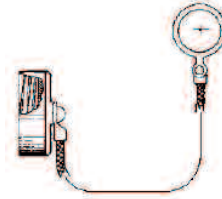

Shell size	Part numbers	
	Plating **	Olive green plating
9	S2453-09W-**-1	D38999/33 W 09 N
11	S2453-11W-**-1	D38999/33 W 11 N
13	S2453-13W-**-1	D38999/33 W 13 N
15	S2453-15W-**-1	D38999/33 W 15 N
17	S2453-17W-**-1	D38999/33 W 17 N
19	S2453-19W-**-1	D38999/33 W 19 N
21	S2453-21W-**-1	D38999/33 W 21 N
23	S2453-23W-**-1	D38999/33 W 23 N
25	S2453-25W-**-1	D38999/33 W 25 N

Caps for plug (D38999/32 - S2454)

With stainless steel rope and eyelet

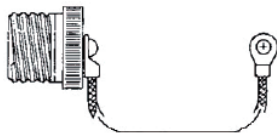

Shell size	Part numbers	
	Plating **	Olive green plating
9	S2454-09F-** S	D38999/32 W 09 R
11	S2454-11F-** S	D38999/32 W 11 R
13	S2454-13F-** S	D38999/32 W 13 R
15	S2454-15F-** S	D38999/32 W 15 R
17	S2454-17F-** S	D38999/32 W 17 R
19	S2454-19F-** S	D38999/32 W 19 R
21	S2454-21F-** S	D38999/32 W 21 R
23	S2454-23F-** S	D38999/32 W 23 R
25	S2454-25F-** S	D38999/32 W 25 R

With stainless steel rope and ring

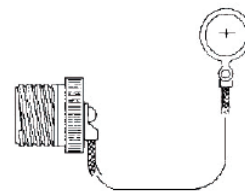

Shell size	Part numbers	
	Plating **	Olive green plating
9	S2454-09W-** S	D38999/32 W 09 N
11	S2454-11W-** S	D38999/32 W 11 N
13	S2454-13W-** S	D38999/32 W 13 N
15	S2454-15W-** S	D38999/32 W 15 N
17	S2454-17W-** S	D38999/32 W 17 N
19	S2454-19W-** S	D38999/32 W 19 N
21	S2454-21W-** S	D38999/32 W 21 N
23	S2454-23W-** S	D38999/32 W 23 N
25	S2454-25W-** S	D38999/32 W 25 N

Plating - 34: Olive green cadmium - Plating - 12: Nickel. Note: caps available with nylon ropes. Consult us.

8D - D38999 Aluminium Series



Connectors weight

	With contacts						Without contact					
	Plug (type 5)		Receptacle (type 0)		Receptacle (type 7)		Plug (type 5)		Receptacle (type 0)		Receptacle (type 7)	
	Male	Female	Male	Female	Male	Female	Male	Female	Male	Female	Male	Female
09 - 35	11.47	13.05	9.15	10.73	13.91	15.49	11.05	11.55	8.73	9.23	13.49	13.99
09 - 98	11.47	12.77	9.15	10.45	13.91	15.21	11.05	11.57	8.73	9.25	13.49	14.01
11 - 01	14.98	17.92	12.01	14.95	18.17	21.11	14.32	16.32	11.35	13.35	17.51	19.51
11 - 02	14.61	17.15	11.64	14.18	17.80	20.34	13.99	15.59	11.02	12.62	17.18	18.78
11 - 04	14.80	17.86	11.83	14.89	17.99	21.05	14.24	16.26	11.27	13.29	17.43	19.45
11 - 05	14.83	18.04	11.86	15.07	19.48	21.23	14.13	16.04	11.16	13.07	17.32	19.23
11 - 22	14.47	16.89	11.50	13.92	17.66	20.08	14.19	15.89	11.22	12.92	17.38	19.08
11 - 35	14.73	18.20	11.76	15.23	17.68	21.39	13.82	14.95	10.85	11.98	17.01	18.14
11 - 80	18.30	21.90	15.30	18.90	21.50	28.39	13.80	14.90	10.80	11.90	17.00	18.10
11 - 98	14.70	17.46	11.73	14.49	17.89	20.65	13.86	15.06	10.89	12.09	17.05	18.25
11 - 99	14.87	18.09	11.90	15.12	18.06	21.28	13.89	15.29	10.92	12.32	17.08	18.48
13 - 04	21.04	24.82	15.71	19.49	24.14	27.92	19.80	21.70	14.47	16.37	22.90	24.80
13 - 08	21.42	26.60	16.09	21.27	24.52	29.70	20.30	23.40	14.97	18.07	23.40	26.50
13 - 26	21.79	27.44	16.46	22.11	24.89	30.54	20.05	22.74	14.72	17.41	23.15	25.84
13 - 35	21.22	26.99	15.89	21.66	24.32	30.09	19.68	21.49	14.35	16.16	22.78	24.59
13 - 98	21.08	25.70	15.75	20.37	24.18	28.80	19.68	21.70	14.35	16.37	22.78	24.80
15 - 05	26.04	31.38	19.54	24.88	29.62	34.96	24.49	27.48	17.99	20.98	28.07	31.06
15 - 15	26.84	34.00	20.34	27.50	30.42	37.58	24.57	27.62	18.07	21.12	28.15	31.20
15 - 18	27.05	35.93	20.55	29.43	30.63	39.51	24.53	28.73	18.03	22.23	28.11	32.31
15 - 19	26.58	34.31	20.08	27.81	30.16	37.89	23.92	26.71	17.42	20.21	27.50	30.29
15 - 35	26.68	35.92	20.18	29.42	30.26	39.50	24.09	26.67	17.59	20.17	27.67	30.25
15 - 97	26.51	33.56	20.01	27.06	30.09	37.14	24.15	27.24	17.65	20.74	27.73	30.82
17 - 02	32.96	46.30	31.26	44.60	42.06	55.40	25.80	29.80	24.10	28.10	34.90	38.90
17 - 06	29.90	39.50	28.21	37.81	39.00	48.60	25.94	29.90	24.25	28.21	35.04	39.00
17 - 08	28.89	37.62	27.20	35.93	37.99	46.72	26.41	31.38	24.72	29.69	35.51	40.48
17 - 26	29.47	40.26	27.78	38.57	38.57	49.36	25.83	29.86	24.14	28.17	34.93	38.96
17 - 35	29.71	43.26	28.02	41.57	38.81	52.36	25.86	29.51	24.17	27.82	34.96	38.61
17 - 75	35.31	46.60	33.62	44.91	44.41	55.70	26.31	32.60	24.62	30.91	35.41	41.70
17 - 99	29.52	40.08	27.83	38.39	38.62	49.18	25.96	30.12	24.27	28.43	35.06	39.22
19 - 11	37.77	51.36	31.07	44.66	44.62	58.21	34.36	42.78	27.66	46.43	30.86	49.63
19 - 32	36.98	50.38	30.28	43.68	43.83	57.23	32.50	37.58	25.80	41.23	29.00	44.43
19 - 35	37.29	53.74	30.59	47.04	44.14	44.09	32.67	37.24	25.97	40.89	29.17	44.09
21 - 11	45.51	65.35	39.31	59.15	53.19	73.03	38.25	47.75	32.05	51.93	35.55	55.43
21 - 16	42.61	57.89	36.41	51.69	50.29	65.57	37.65	45.41	31.45	49.59	34.95	53.09
21 - 35	42.89	63.55	36.69	57.35	50.57	71.23	37.36	43.80	31.16	47.98	34.66	51.48
21 - 39	44.27	64.60	38.07	58.40	51.95	72.28	38.47	48.24	32.27	52.42	35.77	55.92
21 - 41	42.81	60.18	36.61	64.36	50.49	67.86	37.07	43.78	30.87	47.96	34.37	51.46
21 - 48	49.59	49.93	43.39	43.73	55.27	57.61	36.48	43.38	30.28	37.18	44.16	51.06
21 - 75	54.48	71.38	48.28	65.18	62.16	79.06	36.48	43.38	30.28	37.18	44.16	51.06
23 - 21	50.49	73.74	44.19	67.44	59.23	82.48	43.98	57.36	37.68	62.20	41.58	66.10
23 - 35	48.85	75.00	42.55	68.70	57.59	83.74	41.85	50.00	35.55	54.84	39.45	58.74
23 - 53	48.91	71.10	42.61	64.80	57.65	79.84	41.49	49.90	35.19	54.74	39.09	58.64
23 - 55	49.66	72.73	43.36	66.43	58.40	81.47	41.96	50.73	35.66	55.57	39.56	59.47
25 - 07	61.89	90.70	55.73	85.10	71.15	99.10	46.41	56.20	40.25	61.26	44.45	65.46
25 - 11	54.48	71.38	48.28	65.18	62.16	79.06	36.48	43.38	30.28	37.18	44.16	51.06
25 - 19	59.76	91.77	53.60	85.61	69.02	101.03	47.22	61.37	41.06	66.43	45.26	70.63
25 - 24	59.26	90.62	53.10	84.46	68.52	99.88	47.62	62.06	41.46	67.12	45.66	71.32
25 - 29	57.58	86.55	51.42	80.39	66.84	95.81	48.59	63.93	42.43	68.99	46.63	73.19
25 - 35	55.37	88.20	49.21	82.04	64.63	97.46	46.41	56.20	40.25	61.26	44.45	65.46
25 - 37	57.57	89.86	51.41	85.36	66.83	90.06	46.10	61.00	39.94	60.50	45.36	61.20
25 - 44	52.80	67.61	46.53	65.39	62.05	83.39	44.40	59.22	38.14	57.00	43.66	75.00
25 - 43	57.62	88.30	51.46	82.14	66.88	97.56	48.20	63.50	42.04	68.56	46.24	72.76
25 - 46	59.92	83.76	53.76	77.60	69.18	93.02	45.28	55.44	39.12	60.50	43.32	64.70
25 - 61	54.67	81.42	48.51	75.26	63.93	90.68	46.13	57.02	39.97	62.08	44.17	66.28
25 - 08	81.00	112.83	74.84	106.67	90.26	122.09	45.00	56.83	38.84	61.69	43.04	66.09
25 - 20	66.02	96.24	59.86	90.08	75.28	105.50	44.45	54.70	38.29	59.76	42.49	63.96
25 - 04	58.42	88.27	52.26	82.11	67.68	97.53	49.22	62.83	43.06	67.89	47.26	72.09

Weight in gram

8D - D38999 Composite Series



MIL-DTL-38999 Serie III Composite Series



8D - D38999 Composite Series

Connector part numbers

Basic Series	8D	0	-	11	J	35	P	N	-	-	L
Shell style:											
0: Square flange receptacle											
5: Plug with RFI shielding											
Type:											
None: Connectors with standard crimp contacts.											
L: Receptacle with long spill (male and female size #22D, #20).											
C: Receptacle with short spill (male and female #22D, #20, #16).											
S: Receptacle with specific spill (male et female #22D)											
W: Receptacle with male contacts #22D for wire wrap (3 wraps)											
T: Receptacle with male contacts #20 for wire wrap (2 wraps)											
P: Receptacle with solder cup (male and female size #22D; male #16 & #12; female #16 & #12 and male female #20 please consult us)											
Shell size: 09 - 11 - 13 - 15 - 17 - 19 - 21 - 23 - 25											
Plating:											
J: Olive drab cadmium											
M: Nickel											
X: Without plating											
Contact layout: See page 10 to 13											
Contact type:											
P: Pin (500 mating/unmating)											
H: Pin (1500 mating/unmating)											
A: Connector supplied less pin contact or with specific contacts (connector marking: A + orientation)											
S: Socket (500 mating/unmating)											
J: Socket (1500 mating/unmating)											
B: Connector supplied less socket contact or with specific contacts (connector marking: B + orientation)											
Orientation: N, A, B, C, D & E (see page 63)											
Specification:											
046: Tinned straight spills											
251: Connector provided with power contacts (layouts with contact #8)											
022: Fuel tank											
Special custom:											
None: Standard plastic cap											
M: Antistatic plastic cap											
L: For P or S contact type only, connectors delivered without contacts, connectors marking P or S plus orientation.											

MIL-DTL-38999 part numbers*

Basic Series	D38999	20	M	B	35	P	N	L
Shell style:								
20: Square flange receptacle								
26: Plug with RFI shielding.								
Plating:								
J: Olive drab cadmium								
M: Nickel								
Shell size: A - B - C - D - E - F - G - H - J								
Contact layout: See page 14 for layout according to MIL-DTL-38999								
Contact type:								
P: Pin (500 mating/unmating)								
H: Pin (1500 mating/unmating)								
A: Connector supplied less pin contact or with specific contacts (connector marking: A + orientation)								
S: Socket (500 mating/unmating)								
J: Socket (1500 mating/unmating)								
B: Connector supplied less socket contact or with specific contacts (connector marking: B + orientation)								
Orientation: N, A, B, C, D & E (see page 63)								
L: For P or S contact type only, connector delivered without contacts, connector marking P or S (without L)								

* Note: To place an order of MIL connectors delivered without MIL removable crimp contacts and keep P or S plus orientation marking, it must be specify clearly on the order (by adding a suffix L at the end of the P/N or specified in comment).

8D - D38999 Composite Series



Dimensions

Receptacle type 0

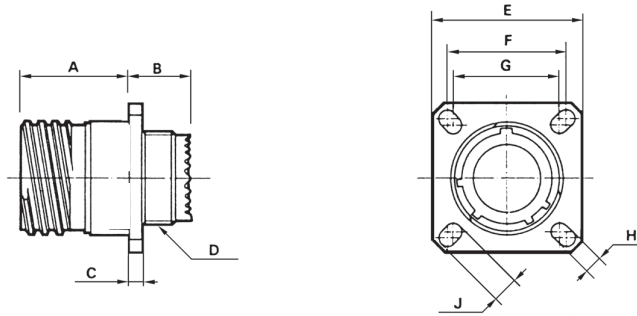

Shell size	A Max.	B Max.	C Max.	D thread	E $\pm 0,30$	F	G	H $\pm 0,20$	J $\pm 0,20$
09 (A)	19.65	11.96	3.65	M12 x 1-6g	23.80	18.26	15.09	3.25	5.49
11 (B)	19.65	11.96	3.65	M15 x 1-6g	26.20	20.62	18.26	3.25	4.93
13 (C)	19.65	11.96	3.65	M18 x 1-6g	28.60	23.01	20.62	3.25	4.93
15 (D)	19.65	11.96	3.65	M22 x 1-6g	31.00	24.61	23.01	3.25	4.39
17 (E)	19.65	11.96	3.65	M25 x 1-6g	33.30	26.97	24.61	3.25	4.93
19 (F)	19.65	11.96	3.65	M28 x 1-6g	36.50	29.36	26.97	3.25	4.93
21 (G)	18.85	12.76	4.35	M31 x 1-6g	39.70	31.75	29.36	3.25	4.93
23 (H)	18.85	12.76	4.35	M34 x 1-6g	42.90	34.93	31.75	3.91	6.15
25 (J)	18.85	12.76	4.35	M37 x 1-6g	46.00	38.10	34.93	3.91	6.15

Dimensions in millimeters

8D - D38999 Composite Series



Plug type 5

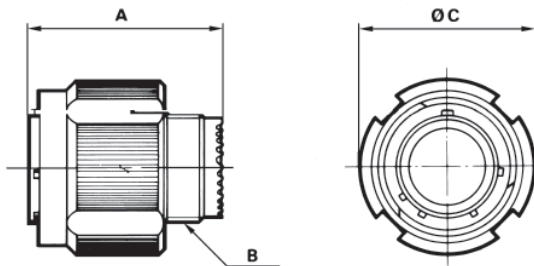

Shell size	A Max.	B thread	C Max.
09 (A)	31.00	M12 x 1-6g	21.80
11 (B)	31.00	M15 x 1-6g	25.00
13 (C)	31.00	M18 x 1-6g	29.40
15 (D)	31.00	M22 x 1-6g	32.50
17 (E)	31.00	M25 x 1-6g	35.70
19 (F)	31.00	M28 x 1-6g	38.50
21 (G)	31.00	M31 x 1-6g	41.70
23 (H)	31.00	M34 x 1-6g	44.90
25 (J)	31.00	M37 x 1-6g	48.00

Mated connectors dimensions

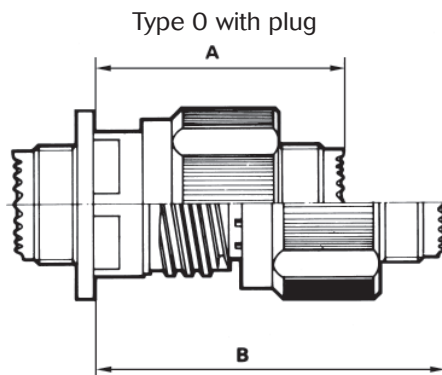

Shell size	A Max.	B Max.
09 (A)	37.00	52.30
11 (B)	37.00	52.30
13 (C)	37.00	52.30
15 (D)	37.00	52.30
17 (E)	37.00	52.30
19 (F)	37.00	52.30
21 (G)	36.00	51.30
23 (H)	36.00	51.30
25 (J)	36.00	51.30

Dimensions in millimeters

8D - D38999 Composite Series



Receptacle with straight spill contacts

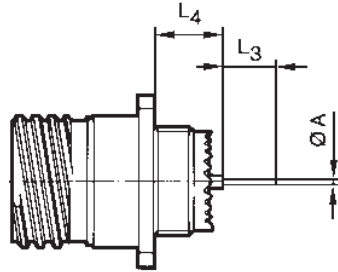

	Shell size			09 (A)	11 (B)	13 (C)	15 (D)	17 (E)	19 (F)	21 (G)	23 (H)	25 (J)
	Contact size	Contact type	Spill type									
A	# 22D	M & F	L & C					0.70				
	# 22D	M & F	S					0.50				
	# 20	M & F	C					0.70				
	# 16	M & F	C					1.15				
L3	# 22D	M & F	L					8.50				
	# 22D	M & F	C					4.00				
	# 22D	M & F	S					5.00				
	# 20	M & F	C					5.00				
	# 16	M & F	C					5.00				
L4	Min.	# 22D	M					9.48				
	Max.	# 22D	M				10.38				10.48	
	Min.	# 22D	F				9.15				9.26	
	Max.	# 22D	F				10.58				10.69	
	Min.	# 22D	M				9.65				9.76	
	Max.	# 22D	M				10.55				10.65	
	Min.	# 22D	F				9.65				9.76	
	Max.	# 22D	F				10.55				10.65	
	Min.	# 20	M				9.65				9.76	
	Max.	# 20	M				10.55				10.65	
	Min.	# 20	F				9.65				9.76	
	Max.	# 20	F				10.55				10.65	
	Min.	# 16	M				9.65				9.76	
	Max.	# 16	M				10.55				10.65	
	Min.	# 16	F				9.65				9.76	
	Max.	# 16	F				10.55				10.65	

M : Male contact F: Female contact L: Long spill C : Short spill S: Specific spill

Dimensions in millimeters

8D - D38999 Composite Series



Standard backshells part numbers

Straight cable clamp (M85049/91)

Basic series M85049 91 11 M

Backshell type:
91: Straight cable clamp

Shell size:
09 - 11 - 13 - 15 - 17 - 19 - 21 - 23 - 25

Plating:
J: Cadmium olive drab over electroless nickel
M: Electroless nickel
T: Without plating

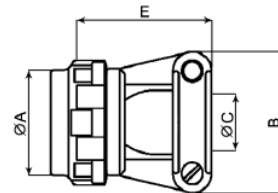

See table 1 for dimensions

90° cable clamp (M85049/92)

Basic series M85049 92 11 M

Backshell type:
92: 90° cable clamp

Shell size:
09 - 11 - 13 - 15 - 17 - 19 - 21 - 23 - 25

Plating:
J: Cadmium olive drab over electroless nickel
M: Electroless nickel
T: Without plating

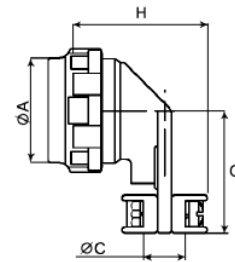

See table 1 for dimensions

Table 1

Shell size	ØA Max.	B Max.	ØC Max.	E Max.	G	H
09	21.80	24.90	5.55	21.25	22.20	26.95
11	25.00	26.0	6.70	24.30	23.80	27.95
13	29.40	30.50	8.75	27.95	26.20	30.00
15	32.50	33.00	11.70		28.60	33.00
17	35.70	36.10	13.85	31.25	33.30	35.05
19	38.50	38.60	15.60	35.80	34.95	36.85
21	41.50	41.65	17.75	38.35	38.10	39.15
23	44.90	45.00	19.80	42.15	41.30	41.15
25	48.00	48.00	21.60	44.70	44.45	42.95

Dimensions in millimeters

8D - D38999 Composite Series



Straight backshell for heat shrink boots accommodation (M85049/88)

Basic series **M85049** **88** **11** **M** **02**

Backshell type:

88: Straight backshell for heat shrink boots

Shell size:

09 - 11 - 13 - 15 - 17 - 19 - 21 - 23 - 25

Plating:

J: Cadmium olive drab over electroless nickel

M: Electroless nickel

Entry size:

02 ou **03:** see table 2

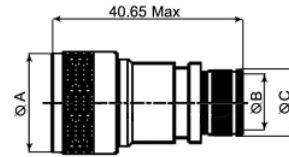

See tableau 2 for dimensions

Table 2

Shell size	ØA Max.	ØB +/- 0.10 Entry size		ØC	
		02	03	02	03
09	21.79	N/A	6.35	N/A	10.03
11	24.99	N/A	7.92	N/A	11.61
13	29.39	7.92	11.13	11.61	14.81
15	32.49	11.13	14.27	14.81	17.96
17	35.71	12.70	15.88	16.38	19.56
19	38.51	15.88	19.05	19.56	22.73
21	41.71	15.88	20.62	19.56	24.30
23	44.91	17.47	23.83	21.06	27.51
25	47.98	19.05	25.40	22.73	29.08

Dimensions in millimeters

8D - D38999 Composite Series



Connectors weight

	With contacts				Without contact			
	Plug (type 5)		Receptacle (type 0)		Plug (type 5)		Receptacle (type 0)	
	Male	Female	Male	Female	Male	Female	Male	Female
09-35	8.5	10.1	7.8	9.4	8.1	8.6	7.4	7.9
09-98	8.5	9.8	7.8	9.1	8.1	8.6	7.4	7.9
11-01	12.8	15.7	10.4	13.3	12.1	14.1	9.7	11.7
11-02	11.5	14.1	09.3	11.8	10.9	12.5	08.7	10.3
11-04	12.6	15.7	10.2	13.3	12.0	14.1	9.7	11.7
11-05	12.6	15.8	10.2	13.4	11.9	13.8	9.5	11.5
11-22	11.4	13.8	09.1	11.6	11.1	12.8	08.8	10.6
11-35	12.5	16.0	10.1	13.6	11.6	12.8	9.2	10.4
11-80	15.25	18.6	13.40	10.4	10.75	11.63	08.90	09.4
11-98	12.5	15.3	10.1	12.9	11.7	12.8	9.3	10.5
11-99	11.8	15.0	09.6	12.8	10.8	12.2	08.6	10.0
13-04	17.2	20.9	13.7	17.5	15.6	17.9	12.4	14.3
13-08	17.6	22.8	14.1	19.2	16.5	19.6	12.9	16.1
13-26	17.9	23.6	14.4	20.1	16.2	18.9	12.7	15.4
13-35	17.4	23.1	13.8	19.6	15.8	17.6	12.3	14.1
13-98	17.2	21.8	13.7	18.3	15.8	17.9	12.3	14.3
15-05	21.4	26.7	16.6	21.9	19.8	22.8	15.0	18.0
15-15	22.2	29.3	17.4	24.5	19.9	23.0	15.1	18.1
15-18	22.4	31.3	17.6	26.5	19.9	24.0	15.0	19.2
15-19	22.0	29.6	17.1	24.8	19.2	22.0	14.5	17.2
15-35	22.0	31.3	17.2	26.5	19.4	22.0	14.6	17.2
15-97	21.8	28.9	17.1	24.1	19.4	22.6	14.7	17.8
17-02	26.51	38.85	25.23	37.57	19.35	22.35	18.07	21.07
17-06	25.9	35.5	23.2	32.8	21.9	25.9	19.2	23.2
17-08	24.9	33.6	22.2	30.1	22.4	27.4	19.7	24.7
17-26	25.5	36.3	22.8	33.6	21.8	25.9	19.2	23.1
17-35	25.7	39.3	23.0	36.6	21.9	25.5	19.2	22.8
17-75	31.3	42.6	28.6	39.9	22.3	28.6	19.6	25.9
17-99	25.5	36.1	22.8	33.4	22.0	26.1	19.3	23.4
19-11	32.1	45.7	26.1	39.7	28.7	37.1	22.7	31.1
19-32	31.3	44.7	25.3	38.7	26.8	31.9	20.8	25.9
19-35	31.6	48.1	25.6	42.0	27.1	31.6	21.0	25.6
21-11	38.0	57.9	32.8	52.6	30.8	40.3	25.5	35.1
21-16	35.1	50.4	29.9	45.2	30.2	37.9	24.9	32.7
21-35	35.4	56.1	30.1	50.8	29.9	36.3	24.6	31.1
21-39	36.8	57.1	31.5	51.9	31.0	40.8	25.7	35.5
21-41	35.3	52.7	30.1	47.5	29.6	36.3	24.3	31.0
21-48	42.41	62.40	37.71	57.70	29.3	36.2	24.6	31.5
21-75	47.3	64.2	42.6	59.50	29.3	36.2	24.6	31.5
23-21	43.1	66.3	38.0	61.2	36.5	49.9	31.5	44.8
23-35	41.4	67.5	36.3	62.5	34.4	42.5	29.3	37.5
23-53	41.5	63.6	36.4	58.6	34.1	42.4	29.0	37.4
23-55	42.2	65.3	42.2	60.2	34.5	43.3	29.4	38.2
25-07	53.6	90.05	49.0	84.85	37.8	51.8	33.2	46.6
25-11	59.08	81.60	54.48	77.00	40.8	53.8	36.2	49.2
25-19	51.7	83.7	46.6	78.6	39.2	53.3	34.0	48.2
25-24	51.2	82.5	46.1	77.4	39.6	54.0	34.4	48.9
25-29	49.5	78.5	44.4	73.4	40.5	55.9	35.4	50.7
25-35	47.3	80.1	42.2	75.0	38.4	48.1	33.2	43.0
25-37	49.27	80.36	45.47	76.16	37.8	51.50	34.0	47.30
25-44	69.64	93.70	65.04	94.65	36.1	45.80	31.5	46.75
25-43	49.6	80.2	44.4	75.1	40.1	55.4	35.0	50.3
25-46	51.9	75.7	46.7	70.1	37.2	47.4	32.1	42.2
25-61	46.6	73.4	41.5	68.2	38.1	48.9	32.9	43.8
25-08	72.9	104.8	67.8	99.6	36.9	48.8	31.8	43.6
25-20	57.9	88.2	52.8	83.0	36.4	46.6	31.3	41.5
25-04	50.4	80.2	45.3	75.0	41.2	54.8	36.1	49.6

8D - D38999 Stainless steel



MIL-DTL-38999 Serie III
Stainless steel

8D - D38999 Stainless steel



Connector part numbers

Basic Series	8D	0	-	11	K	35	P	N	**
Shell style:									
<ul style="list-style-type: none"> 0: Square flange receptacle 1: In line receptacle 7: Jam nut receptacle 5: Plug with RFI shielding. 									
Type:									
<ul style="list-style-type: none"> -: Connectors with standard crimp contacts. L: Receptacle with long spill (male and female size #22D, #20). C: Receptacle with short spill (male and female #22D, #20, #16). S: Receptacle with specific spill (male et female #22D) W: Receptacle with male contacts #22D for wire wrap (3 wraps) T: Receptacle with male contacts #20 for wire wrap (2 wraps) 									
Shell size: 09 - 11 - 13 - 15 - 17 - 19 - 21 - 23 - 25									
Plating:									
<ul style="list-style-type: none"> K: Passivated S: Nickel 									
Contact layout: See page 8 to 11									
Contact type:									
<ul style="list-style-type: none"> P: Pin A: Connector supplied less pin contact or with specific contacts (Connector marking: A+ orientation) S: Socket B: Connector supplied less socket contact or with specific contacts (Connector marking: B+ orientation) 									
Orientation: N, A, B, C, D & E (See page 58)									
Spécification:									
<ul style="list-style-type: none"> 046: Tinned straight spills 251: Connector provided with power contacts (layouts with contacts #8) 022: Fuel tank L: For P or S contact type only, connectors delivered without contacts, connectors marking P or S plus orientation. 									

MIL-DTL 38999 part numbers*

Basic Series	D38999	20	K	B	35	P	N	L
Shell style:								
<ul style="list-style-type: none"> 20: Square flange receptacle 24: Jam nut receptacle 26: Plug with RFI shielding. 								
Plating:								
<ul style="list-style-type: none"> K: Passivated S: Nickel 								
Shell size: A - B - C - D - E - F - G - H - J								
Contact layout: See page 11 for layout according to MIL-DTL-38999								
Contact type:								
<ul style="list-style-type: none"> P: Pin. A: Connector supplied less pin contact or with specific contacts (connector marking: A + orientation). S: Socket. B: Connector supplied less socket contact or with specific contacts (connector marking: B + orientation). 								
Orientation: N, A, B, C, D & E (see page 58)								
L: For P or S contact type only, connector delivered without contacts, connector marking P or S (without L)								

* **Note:** To place an order of MIL connectors delivered without MIL removable crimp contacts and keep P or S plus orientation marking, it must be specify clearly on the order (by adding a suffix L at the end of the P / N or specified in comment).

8D - D38999 Stainless steel



Dimensions

Receptacle type 0

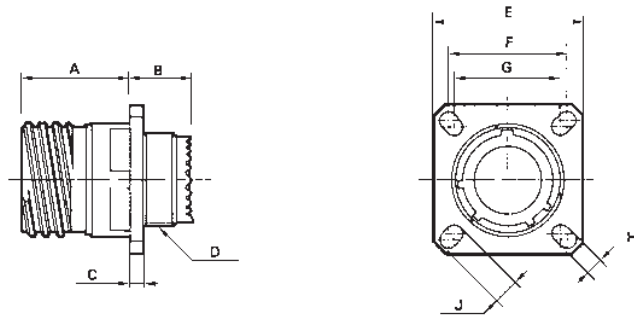

Shell size	A Max.	B Max.	C Max.	D thread	E ± 0,30	F	G	H ± 0,20	J ± 0,20
09 (A)	20.90	10.60	2.50	M12 x 1-6g	23.80	18.26	15.09	3.25	5.49
11 (B)	20.90	10.60	2.50	M15 x 1-6g	26.20	20.62	18.26	3.25	4.93
13 (C)	20.90	10.60	2.50	M18 x 1-6g	28.60	23.01	20.62	3.25	4.93
15 (D)	20.90	10.60	2.50	M22 x 1-6g	31.00	24.61	23.01	3.25	4.93
17 (E)	20.90	10.60	2.50	M25 x 1-6g	33.30	26.97	24.61	3.25	4.93
19 (F)	20.90	10.60	2.50	M28 x 1-6g	36.50	29.36	26.97	3.25	4.93
21 (G)	20.10	11.40	3.20	M31 x 1-6g	39.70	31.75	29.36	3.25	4.93
23 (H)	20.10	11.40	3.20	M34 x 1-6g	42.90	34.93	31.75	3.91	6.15
25 (J)	20.10	11.40	3.20	M37 x 1-6g	46.00	38.10	34.93	3.91	6.15

Receptacle type 7

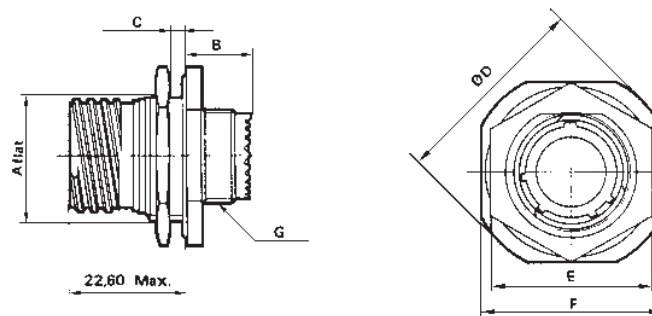

Shell size	A + 0.10 - 0.15	B Max.	C Max.	D Max.	E Max.	F ± 0.4	G thread
09 (A)	16.53	9.90	3.20	30.50	23.00	27.00	M12 x 1-6g
11 (B)	19.07	9.90	3.20	35.20	26.00	31.80	M15 x 1-6g
13 (C)	23.82	9.90	3.20	38.40	31.00	34.90	M18 x 1-6g
15 (D)	26.97	9.90	3.20	41.60	34.00	38.10	M22 x 1-6g
17 (E)	30.15	9.90	3.20	44.80	37.00	41.30	M25 x 1-6g
19 (F)	33.32	9.90	3.20	49.50	41.00	46.00	M28 x 1-6g
21 (G)	36.50	9.90	3.20	52.70	46.00	49.20	M31 x 1-6g
23 (H)	39.67	9.90	3.20	55.90	47.00	52.40	M34 x 1-6g
25 (J)	42.85	9.90	3.20	59.00	52.00	55.60	M37 x 1-6g

Dimensions in millimeters

8D - D38999 Stainless steel



In line receptacle type 1

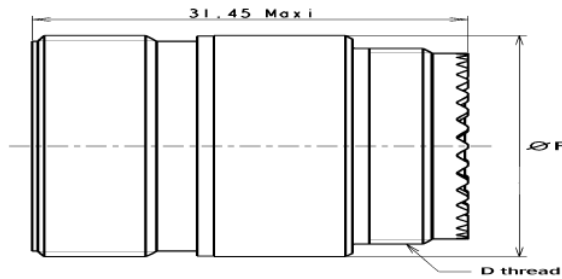

Shell size	D thread	Ø F
09 (A)	M12 x 1-6g	15.90
11 (B)	M15 x 1-6g	19.05
13 (C)	M18 x 1-6g	22.25
15 (D)	M22 x 1-6g	25.40
17 (E)	M25 x 1-6g	30.15
19 (F)	M28 x 1-6g	31.75
21 (G)	M31 x 1-6g	34.75
23 (H)	M34 x 1-6g	37.10
25 (J)	M37 x 1-6g	41.30

Plug type 5

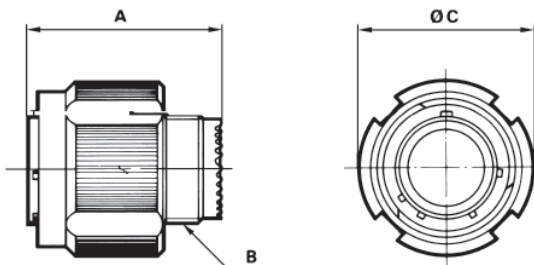

Shell size	A Max.	B thread	C Max.
09 (A)	31.00	M12 x 1-6g	21.80
11 (B)	31.00	M15 x 1-6g	25.00
13 (C)	31.00	M18 x 1-6g	29.40
15 (D)	31.00	M22 x 1-6g	32.50
17 (E)	31.00	M25 x 1-6g	35.70
19 (F)	31.00	M28 x 1-6g	38.50
21 (G)	31.00	M31 x 1-6g	41.70
23 (H)	31.00	M34 x 1-6g	44.90
25 (J)	31.00	M37 x 1-6g	48.00

Maximum coupling torque on panel for jam nut receptacle (type 7)

Shell	09 (A)	11 (B)	13 (C)	15 (D)	17 (E)	19 (F)	21 (G)	23 (H)	25 (J)
Coupling torque (N.m)	6	8	10	13	20	23	25	26	28

Mated connectors dimensions

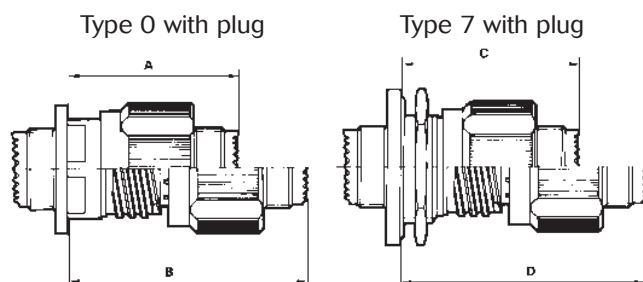

Shell size	A Max.	B Max.	C Max.	D Max.
09 (A)	37.00	52.30	38.30	53.60
11 (B)	37.00	52.30	38.30	53.60
13 (C)	37.00	52.30	38.50	53.80
15 (D)	37.00	52.30	38.50	53.80
17 (E)	37.00	52.30	38.50	53.80
19 (F)	37.00	52.30	38.50	53.80
21 (G)	36.00	51.30	38.50	53.80
23 (H)	36.00	51.30	38.50	53.80
25 (J)	36.00	51.30	38.50	53.80

Dimensions in millimeters

8D - D38999 Stainless steel



Receptacle with straight spill contacts



		Shell size			09 (A)	11 (B)	13 (C)	15 (D)	17 (E)	19 (F)	21 (G)	23 (H)	25 (J)
		Contact size	Contact type	Spill type									
A		# 22D	M & F	L & C					0,70				
		# 22D	M & F	S					0,50				
		# 20	M & F	C					0,70				
		# 16	M & F	C					1,15				
L2	Min.	# 22D	M	L & C	10,52					10,34			
	Max.	# 22D	M	L & C	11,46					11,28			
	Min.	# 22D	F	L & C	10,19					10,01			
	Max.	# 22D	F	L & C	11,46					11,28			
	Min.	# 22D	M	S	10,69					10,51			
	Max.	# 22D	M	S	11,63					11,45			
	Min.	# 22D	F	S	10,36					10,18			
	Max.	# 22D	F	S	11,63					11,45			
	Min.	# 20	M	C	10,69					10,51			
	Max.	# 20	M	C	11,63					11,45			
	Min.	# 20	F	C	10,69					10,51			
	Max.	# 20	F	C	11,63					11,45			
	Min.	# 16	M	C	10,69					10,51			
	Max.	# 16	M	C	11,63					11,45			
L3		# 22D	M & F	L					8,50				
		# 22D	M & F	C					4,00				
		# 22D	M & F	S					5,10				
		# 20	M & F	C					5,10				
		# 16	M & F	C					5,10				
L4	Min.	# 22D	M	L & C			9,48					9,59	
	Max.	# 22D	M	L & C			10,58					10,69	
	Min.	# 22D	F	L & C			9,15					9,26	
	Max.	# 22D	F	L & C			10,58					10,69	
	Min.	# 22D	M	S			9,65					9,76	
	Max.	# 22D	M	S			10,75					10,86	
	Min.	# 22D	F	S			9,15					9,26	
	Max.	# 22D	F	S			10,75					10,86	
	Min.	# 20	M	C			9,65					9,76	
	Max.	# 20	M	C			10,75					10,86	
	Min.	# 20	F	C			9,65					9,76	
	Max.	# 20	F	C			10,75					10,86	
	Min.	# 16	M	C			9,65					9,76	
	Max.	# 16	M	C			10,75					10,86	
Min.	# 16	F	C			9,65					9,76		
Max.	# 16	F	C			10,75					10,86		

M : Male contact F: Female contact L: Long spill C : Short spill S: Specific spill

Dimensions in millimeters

8D - D38999 Stainless steel



Connectors weight

	With contacts						Without contact					
	Plug (type 5)		Receptacle (type 0)		Receptacle (type 7)		Plug (type 5)		Receptacle (type 0)		Receptacle (type 7)	
	Male	Female	Male	Female	Male	Female	Male	Female	Male	Female	Male	Female
09-35	30.63	32.21	23.93	25.51	33.93	35.51	30.21	30.71	23.51	24.01	33.51	34.01
09-98	30.63	31.93	23.93	25.23	33.93	35.23	30.21	30.73	23.51	24.03	33.51	34.03
11-01	38.13	41.07	29.53	32.47	42.43	45.37	37.47	39.47	28.87	30.87	41.77	43.77
11-02	37.76	40.30	39.36	30.12	46.98	49.52	37.14	38.74	28.56	30.16	46.36	47.96
11-04	37.95	41.01	29.35	32.41	42.25	45.31	37.39	39.41	28.79	30.81	41.69	43.71
11-05	37.98	41.19	29.38	32.59	42.04	45.49	37.28	39.19	28.68	30.59	41.58	43.49
11-22	37.48	39.54	28.90	130.86	46.70	48.76	37.34	39.04	28.76	30.36	46.56	48.26
11-35	37.88	41.35	29.28	32.75	41.94	45.65	36.97	38.10	28.37	29.50	41.27	42.40
11-80	38.12	44.84	29.73	36.26	47.78	54.06	34.86	37.84	26.45	29.26	44.51	47.06
11-98	37.85	40.61	29.25	32.01	42.15	44.91	37.01	38.21	28.41	29.61	41.31	42.51
11-99	38.02	41.24	29.44	32.66	47.24	50.46	37.04	38.44	28.46	29.86	46.26	47.66
13-04	53.34	57.12	37.94	41.72	56.24	60.02	52.10	54.00	36.70	38.60	55.00	56.90
13-08	53.72	58.90	38.32	43.50	56.62	61.80	52.60	55.70	37.20	40.30	55.50	58.60
13-26	54.09	59.74	38.69	44.34	56.99	62.64	52.35	55.04	36.95	39.64	55.25	57.94
13-35	53.52	59.29	38.12	43.89	56.42	62.19	51.98	53.79	36.58	38.39	54.88	56.69
13-98	53.38	58.00	37.98	42.60	56.28	60.90	51.98	54.00	36.58	38.60	54.88	56.90
15-05	64.49	69.83	45.69	51.03	67.59	72.93	62.94	65.93	44.14	47.13	66.04	69.03
15-15	65.29	72.45	46.49	53.65	68.39	75.55	63.02	66.07	44.22	47.27	66.12	69.17
15-18	65.50	74.38	46.70	55.58	68.60	77.48	62.98	67.18	44.18	48.38	66.08	70.28
15-19	65.03	72.76	46.23	53.96	68.13	75.86	62.37	65.16	43.57	46.36	65.47	68.26
15-35	65.13	74.37	46.33	55.57	68.23	77.47	62.54	65.12	43.74	46.32	65.64	68.22
15-97	64.96	72.01	46.16	53.21	68.06	75.11	62.60	65.69	43.80	46.89	65.70	68.79
17-02	77.80	92.64	72.89	87.73	104.09	118.95	74.53	86.09	69.62	81.18	100.82	112.38
17-06	69.07	78.67	64.17	73.77	87.27	96.87	65.11	69.07	60.21	64.17	83.31	87.27
17-08	68.06	76.79	63.16	71.89	86.26	94.99	65.58	70.55	60.68	65.65	83.78	88.75
17-26	68.64	79.43	63.74	74.53	86.84	97.63	65.00	69.03	60.10	64.13	83.20	87.23
17-35	68.88	82.43	63.98	77.53	87.08	100.63	65.03	68.68	60.13	63.78	83.23	86.88
17-75	74.48	85.77	69.58	80.87	92.68	103.97	65.48	71.77	60.58	66.87	83.68	89.97
17-99	68.69	79.25	63.79	74.35	86.89	97.45	65.13	69.29	60.23	64.39	83.33	87.49
19-11	87.04	100.63	67.69	81.28	97.59	111.18	83.63	92.05	64.28	73.45	94.18	103.35
19-32	86.25	99.65	66.90	80.30	96.80	110.20	81.77	86.85	62.42	67.50	92.32	97.40
19-35	86.56	103.01	67.21	83.66	97.11	113.56	81.94	86.51	62.59	67.16	92.49	97.06
21-11	99.71	119.55	81.81	101.65	111.81	131.65	92.45	101.95	74.55	84.05	104.55	114.05
21-16	96.81	112.09	78.91	94.19	108.91	124.19	91.85	99.61	73.95	81.71	103.95	111.71
21-35	97.09	117.75	79.19	99.85	109.19	129.85	91.56	98.00	73.66	80.10	103.66	110.10
21-39	98.47	118.80	80.57	100.90	110.57	130.90	92.67	102.44	74.77	84.54	104.77	114.54
21-41	97.01	114.38	79.11	126.48	109.11	126.48	91.27	97.98	73.37	80.08	103.37	80.08
21-48	103.84	123.82	85.93	105.91	126.02	146.02	90.72	97.62	72.81	79.71	112.92	119.82
21-75	108.72	125.62	90.81	107.71	130.92	147.82	90.72	97.62	72.81	79.71	112.92	119.82
23-21	108.81	132.06	90.61	113.86	122.81	146.06	102.30	115.68	84.10	97.48	116.30	129.68
23-35	107.17	133.32	88.97	115.12	121.17	147.32	100.17	108.32	81.97	90.12	114.17	122.32
23-53	107.23	129.42	89.03	111.22	121.23	143.42	99.81	108.22	81.61	90.02	113.81	122.22
23-55	107.98	131.05	89.78	112.85	121.98	145.05	100.28	109.05	82.08	90.85	114.28	123.05
25-07	133.3	157.7	115.5	172.25	160.06	172.25	108.51	119.45	90.71	101.65	135.27	101.65
25-11	132.31	152.31	114.51	134.51	159.71	179.07	111.51	124.51	93.71	106.71	138.91	151.27
25-19	122.14	154.15	104.34	136.35	136.74	168.75	109.60	123.75	91.80	105.95	124.20	138.35
25-24	121.64	153.00	103.84	135.20	136.24	167.60	110.00	124.44	92.20	106.64	124.60	139.04
25-29	119.96	148.93	102.16	131.13	134.56	163.53	110.97	126.31	93.17	108.51	125.57	140.91
25-35	117.75	150.58	99.95	132.78	132.35	165.18	108.79	118.58	90.99	100.78	123.39	133.18
25-37	119.98	148.26	102.18	162.67	146.74	162.67	108.51	119.40	90.71	101.60	135.27	101.60
25-44	140.35	164.98	122.55	179.58	167.11	179.71	106.81	117.08	89.01	99.28	133.57	99.41
25-43	120.00	150.68	102.20	132.88	134.60	165.28	110.58	125.88	92.78	108.08	125.18	140.48
25-46	122.30	146.14	104.50	128.34	136.90	160.74	107.66	117.82	89.86	100.02	122.26	132.42
25-61	117.05	143.80	99.25	126.00	131.65	158.40	108.51	119.40	90.71	101.60	123.11	155.51
25-08	143.38	175.21	125.58	157.41	157.98	189.81	107.38	119.21	89.58	101.41	121.98	133.81
25-20	128.40	158.62	110.60	140.82	143.00	173.22	106.83	117.08	89.03	99.28	121.43	131.68
25-04	120.80	150.65	103.00	132.85	135.40	165.25	111.60	125.21	93.80	107.41	126.20	139.81

Weight in gram

8D Titanium Series



Derived from:
MIL-DTL-38999 Serie III

8D Titanium Series



Connector part numbers

Basic Series	8D	0	-	11	TT	35	S	N	**
Shell style: 0: Square flange receptacle 1: In line receptacle 7: Jam nut receptacle 77: Specific receptacle (please consult us) 5: Plug with RFI shielding.									
Type: -: Connectors with standard crimp contacts. L: Receptacle with long spill (male and female size #22D, #20). C: Receptacle with short spill (male and female #22D, #20, #16). S: Receptacle with specific spill (male et female #22D) W: Receptacle with male contacts #22D for wire wrap (3 wraps) T: Receptacle with male contacts #20 for wire wrap (2 wraps)									
Shell size: 09 - 11 - 13 - 15 - 17 - 19 - 21 - 23 - 25									
Plating: TT: Unplated TF: Nickel plated									
Contact layout: See page 8 to 11									
Contact type: P: Pin A: Connector supplied less pin contact or with specific contacts (Connector marking: A+ orientation) S: Socket B: Connector supplied less socket contact or with specific contacts (Connector marking: B+ orientation)									
Orientation: N, A, B, C, D & E (See page 58)									
Spécification: 046: tinned straight spills 251: Connector provided with power contacts (layouts with contacts #8) 022: Fuel Tank L: For P or S contact only, connectors delivered without contacts, connectors marking P or S plus orientation.									

8D Titanium Series



Dimensions

Receptacle type 0

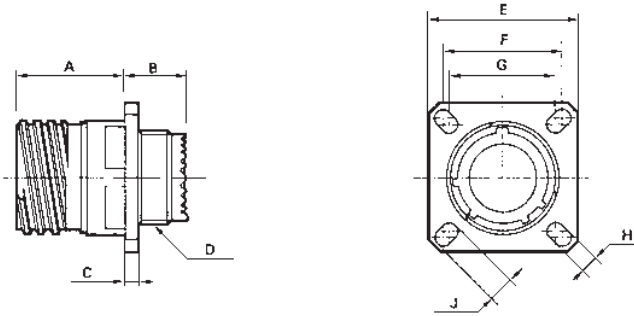

Shell size	A Max.	B Max.	C Max.	D thread	E ± 0,30	F	G	H ± 0,20	J ± 0,20
09	20.90	10.60	2.50	M12 x 1-6g	23.80	18.26	15.09	3.25	5.49
11	20.90	10.60	2.50	M15 x 1-6g	26.20	20.62	18.26	3.25	4.93
13	20.90	10.60	2.50	M18 x 1-6g	28.60	23.01	20.62	3.25	4.93
15	20.90	10.60	2.50	M22 x 1-6g	31.00	24.61	23.01	3.25	4.93
17	20.90	10.60	2.50	M25 x 1-6g	33.30	26.97	24.61	3.25	4.93
19	20.90	10.60	2.50	M28 x 1-6g	36.50	29.36	26.97	3.25	4.93
21	20.10	11.40	3.20	M31 x 1-6g	39.70	31.75	29.36	3.25	4.93
23	20.10	11.40	3.20	M34 x 1-6g	42.90	34.93	31.75	3.91	6.15
25	20.10	11.40	3.20	M37 x 1-6g	46.00	38.10	34.93	3.91	6.15

Receptacle type 7

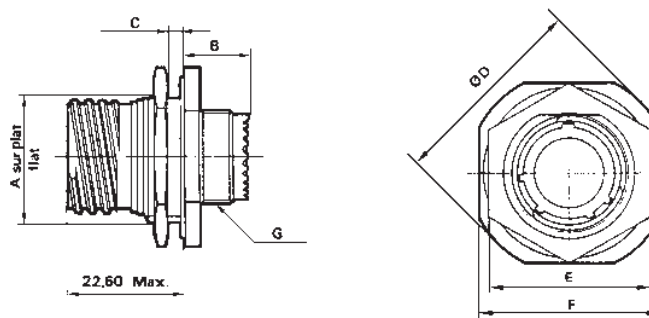

Shell size	A + 0.10 - 0.15	B Max.	C Max.	D Max.	E Max.	F ± 0.4	G thread
09	16.53	9.90	3.20	30.50	23.00	27.00	M12 x 1-6g
11	19.07	9.90	3.20	35.20	26.00	31.80	M15 x 1-6g
13	23.82	9.90	3.20	38.40	31.00	34.90	M18 x 1-6g
15	26.97	9.90	3.20	41.60	34.00	38.10	M22 x 1-6g
17	30.15	9.90	3.20	44.80	37.00	41.30	M25 x 1-6g
19	33.32	9.90	3.50	49.50	41.00	46.00	M28 x 1-6g
21	36.50	9.90	3.50	52.70	46.00	49.20	M31 x 1-6g
23	39.67	9.90	3.50	55.90	47.00	52.40	M34 x 1-6g
25	42.85	9.90	3.50	59.00	52.00	55.60	M37 x 1-6g

Dimensions in millimeters

8D Titanium Series



In line receptacle type 1

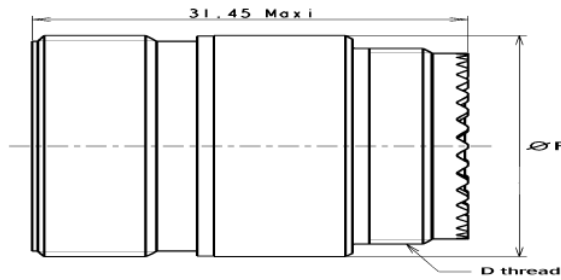

Shell size	D thread	Ø F
09	M12 x 1-6g	15.90
11	M15 x 1-6g	19.05
13	M18 x 1-6g	22.25
15	M22 x 1-6g	25.40
17	M25 x 1-6g	30.15
19	M28 x 1-6g	31.75
21	M31 x 1-6g	34.75
23	M34 x 1-6g	37.10
25	M37 x 1-6g	41.30

Receptacle type 77

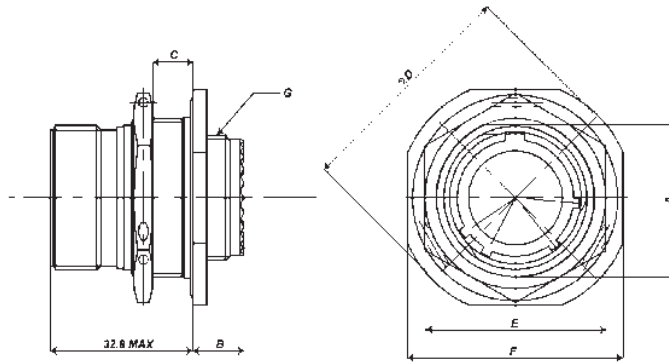

Shell size	A + 0.10 - 0.15	B Max.	C Max.	D Max.	E Max.	F ± 0.4	G thread
09	16.53	9.90	9.60	30.50	23.00	27.00	M12 x 1-6g
11	19.07	9.90	9.60	35.20	26.00	31.80	M15 x 1-6g
13	23.82	9.90	9.60	38.40	31.00	34.90	M18 x 1-6g
15	26.97	9.90	9.60	41.60	34.00	38.10	M22 x 1-6g
17	30.15	9.90	9.60	44.80	37.00	41.30	M25 x 1-6g
19	33.32	9.90	9.60	49.50	41.00	46.00	M28 x 1-6g
21	36.50	9.90	9.60	52.70	46.00	49.20	M31 x 1-6g
23	39.67	9.90	9.60	55.90	47.00	52.40	M34 x 1-6g
25	42.85	9.90	9.60	59.00	52.00	55.60	M37 x 1-6g

Plug type 5

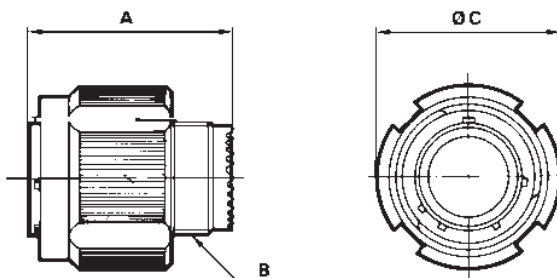

Shell size	A Max.	B thread	C Max.
09	31.00	M12 x 1-6g	21.80
11	31.00	M15 x 1-6g	25.00
13	31.00	M18 x 1-6g	29.40
15	31.00	M22 x 1-6g	32.50
17	31.00	M25 x 1-6g	35.70
19	31.00	M28 x 1-6g	38.50
21	31.00	M31 x 1-6g	41.70
23	31.00	M34 x 1-6g	44.90
25	31.00	M37 x 1-6g	48.00

Dimensions in millimeters

8D Titanium Series



Maximum coupling torque on panel for jam nut receptacle (type 7)

Shell	09	11	13	15	17	19	21	23	25
Coupling torque (N.m)	6	8	10	13	20	23	25	26	28

Mated connectors dimensions

Type 0 with plug

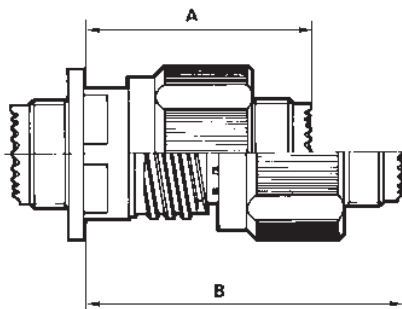

Type 7 with plug

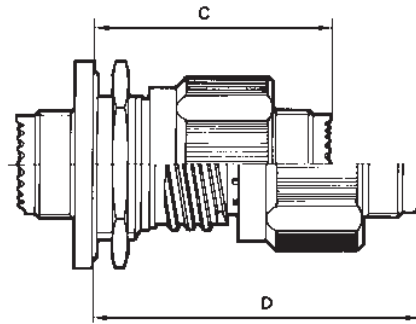

Shell size	A Max.	B Max.	C Max.	D Max.
09	37.00	52.30	38.30	53.60
11	37.00	52.30	38.30	53.60
13	37.00	52.30	38.50	53.80
15	37.00	52.30	38.50	53.80
17	37.00	52.30	38.50	53.80
19	37.00	52.30	38.50	53.80
21	36.00	51.30	38.50	53.80
23	36.00	51.30	38.50	53.80
25	36.00	51.30	38.50	53.80

Dimensions in millimeters

8D Titanium Series



Receptacle with straight spill contacts

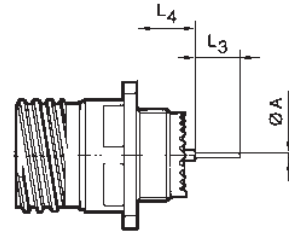
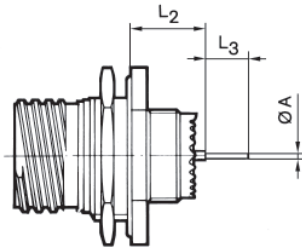

	Shell size			09	11	13	15	17	19	21	23	25
	Contact size	Contact type	Spill type									
A	# 22D	M & F	L & C					0,70				
	# 22D	M & F	S					0,50				
	# 20	M & F	C					0,70				
	# 16	M & F	C					1,15				
L2	Min.	# 22D	M	L & C	10.52				10.34			
	Max.	# 22D	M	L & C	11.46				11.28			
	Min.	# 22D	F	L & C	10.19				10.01			
	Max.	# 22D	F	L & C	11.46				11.28			
	Min.	# 22D	M	S	10.19				10.01			
	Max.	# 22D	M	S	11.46				11.28			
	Min.	# 22D	F	S	10.69				10.51			
	Max.	# 22D	F	S	11.63				11.45			
	Min.	# 20	M	C	10.36				10.18			
	Max.	# 20	M	C	11.63				11.45			
	Min.	# 20	F	C	10.69				10.51			
	Max.	# 20	F	C	11.63				11.45			
	Min.	# 16	M	C	10.69				10.51			
	Max.	# 16	M	C	11.63				11.45			
	Min.	# 16	F	C	10.69				10.51			
	Max.	# 16	F	C	11.63				11.45			
L3	# 22D	M & F	L					8.50				
	# 22D	M & F	C					4.00				
	# 22D	M & F	S					5.10				
	# 20	M & F	C					5.10				
	# 16	M & F	C					5.10				
L4	Min.	# 22D	M	L & C				9.48				
	Max.	# 22D	M	L & C		10.58					10.69	
	Min.	# 22D	F	L & C		9.15					9.26	
	Max.	# 22D	F	L & C		10.58					10.69	
	Min.	# 22D	M	S		9.65					9.76	
	Max.	# 22D	M	S		10.75					10.86	
	Min.	# 22D	F	S		9.15					9.26	
	Max.	# 22D	F	S		10.75					10.86	
	Min.	# 20	M	C		9.65					9.76	
	Max.	# 20	M	C		10.75					10.86	
	Min.	# 20	F	C		9.65					9.76	
	Max.	# 20	F	C		10.75					10.86	
	Min.	# 16	M	C		9.65					9.76	
	Max.	# 16	M	C		10.75					10.86	
	Min.	# 16	F	C		9.65					9.76	
	Max.	# 16	F	C		10.75					10.86	

M : Male contact F: Female contact L: Long spill C : Short spill S: Specific spill

Dimensions in millimeters

8D Titanium Series



Connectors weight*

	With contacts						Without contact					
	Plug (type 5)		Receptacle (type 0)		Receptacle (type 7)		Plug (type 5)		Receptacle (type 0)		Receptacle (type 7)	
	Male	Female	Male	Female	Male	Female	Male	Female	Male	Female	Male	Female
09-35	18.23	19.81	14.37	15.95	20.14	21.72	17.81	18.31	13.95	14.45	19.72	20.22
09-98	18.23	19.53	14.37	15.67	20.14	21.44	17.81	18.33	13.95	14.47	19.72	20.24
11-01	23.15	26.09	18.19	21.13	25.63	28.57	22.49	24.49	17.53	19.53	24.97	26.97
11-02	22.78	25.32	17.82	20.36	28.1	30.64	22.16	23.76	17.2	18.8	27.48	29.08
11-04	22.97	26.03	18.01	21.07	25.45	28.51	22.41	24.43	17.45	19.47	24.89	26.91
11-05	23.00	26.21	18.04	21.25	25.24	28.69	22.30	24.21	17.34	19.25	24.78	26.69
11-22	22.64	25.06	17.68	20.10	27.96	30.38	22.36	24.06	17.40	19.10	27.68	29.38
11-35	22.90	26.37	17.94	21.41	25.14	28.85	21.99	23.12	17.03	18.16	24.47	25.60
11-80	25.38	29.86	20.08	24.88	30.66	35.78	22.10	22.86	16.80	17.88	27.38	28.78
11-98	22.87	25.63	17.91	20.67	25.35	28.11	22.03	23.23	17.07	18.27	24.51	25.71
11-99	23.04	26.26	18.06	21.28	25.53	28.75	22.06	23.46	17.08	18.48	24.55	25.95
13-04	32.44	36.22	23.56	27.34	34.11	37.89	31.20	33.10	22.32	24.22	32.87	34.77
13-08	32.82	38.00	23.94	29.12	34.49	39.67	31.70	34.80	22.82	25.92	33.37	36.47
13-26	33.19	38.84	24.31	29.96	34.86	40.51	31.45	34.14	22.57	25.26	33.12	35.81
13-35	32.62	38.39	23.74	29.51	34.29	40.06	31.08	32.89	22.20	24.01	32.75	34.56
13-98	32.48	37.10	23.60	28.22	34.15	38.77	31.08	33.10	22.20	24.22	32.75	34.77
15-05	39.61	44.95	28.77	34.11	41.40	46.74	38.06	41.05	27.22	30.21	39.85	42.84
15-15	40.41	47.57	29.57	36.73	42.20	49.36	38.14	41.19	27.30	30.35	39.93	42.98
15-18	40.62	49.50	29.78	38.66	42.41	51.29	38.10	42.30	27.26	31.46	39.89	44.09
15-19	40.15	47.88	29.31	37.04	41.94	49.67	37.49	40.28	26.65	29.44	39.28	42.07
15-35	40.25	49.49	29.41	38.65	42.04	51.28	37.66	40.24	26.82	29.40	39.45	42.03
15-97	40.08	47.13	29.24	36.29	41.87	48.92	37.72	40.81	26.88	29.97	39.51	42.60
17-02	48.16	58.40	45.20	55.44	63.99	74.23	44.89	51.85	41.93	48.89	60.72	67.68
17-06	43.73	53.33	40.90	50.50	54.23	63.83	39.77	43.73	36.94	40.90	50.27	54.23
17-08	42.72	51.45	39.89	48.62	53.22	61.95	40.24	45.21	37.41	42.38	50.74	55.71
17-26	43.30	54.09	40.47	51.26	53.80	64.59	39.66	43.69	36.83	40.86	50.16	54.19
17-35	43.54	57.09	40.71	54.26	54.04	67.59	39.69	43.34	36.86	40.51	50.19	53.84
17-75	49.14	60.43	46.31	57.60	59.64	70.93	40.14	46.43	37.31	43.60	50.64	56.93
17-99	43.35	53.91	40.52	51.08	53.85	64.41	39.79	43.95	36.96	41.12	50.29	54.45
19-11	55.16	68.75	44.00	57.59	61.25	74.84	51.75	60.17	40.59	66.26	40.59	66.26
19-32	54.37	67.77	43.21	56.61	60.46	73.86	49.89	54.97	38.73	61.06	38.73	61.06
19-35	54.68	71.13	43.52	59.97	60.77	77.22	50.06	54.63	38.90	60.72	38.90	60.72
21-11	64.64	84.48	54.31	74.15	71.62	91.46	57.38	66.88	47.05	73.86	47.05	73.86
21-16	61.74	77.02	51.41	66.69	68.72	84.00	56.78	64.54	46.45	71.52	46.45	71.52
21-35	62.02	82.68	51.69	72.35	69.00	89.66	56.49	62.93	46.16	69.91	46.16	69.91
21-39	63.40	83.73	53.07	73.40	70.38	90.71	57.60	67.37	47.27	74.35	47.27	74.35
21-41	61.94	79.31	51.61	86.29	68.92	86.29	56.20	62.91	45.87	69.89	45.87	69.89
21-48	68.73	88.71	58.4	78.38	81.56	101.54	55.61	62.51	45.28	52.18	68.44	75.34
21-75	73.61	90.51	63.28	80.18	86.44	103.34	55.61	62.51	45.28	52.18	68.44	75.34
23-21	71.07	94.32	60.57	83.82	79.15	102.40	64.56	77.94	54.06	86.02	54.06	86.02
23-35	69.43	95.58	58.93	85.08	77.51	103.66	62.43	70.58	51.93	78.66	51.93	78.66
23-53	69.49	91.68	58.99	81.18	77.57	99.76	62.07	70.48	51.57	78.56	51.57	78.56
23-55	70.24	93.31	59.74	82.81	78.32	101.39	62.54	71.31	52.04	79.39	52.04	79.39
25-07	83.91	117.09	73.64	123.58	99.34	121.8	68.12	78.84	57.85	85.33	83.55	83.55
25-11	91.92	111.92	81.65	101.65	94.65	127.35	71.12	84.12	60.85	73.85	86.55	99.55
25-19	81.78	113.79	71.51	103.52	90.20	122.21	69.24	83.39	58.97	91.81	85.97	91.81
25-24	81.28	112.64	71.01	102.37	89.70	121.06	69.64	84.08	59.37	92.50	59.37	92.50
25-29	79.60	108.57	69.33	98.30	88.02	116.99	70.61	85.95	60.34	94.37	60.34	94.37
25-35	77.39	110.22	67.12	99.95	85.81	118.64	68.43	78.22	58.16	86.64	58.16	86.64
25-37	79.59	107.09	69.32	116.12	95.02	113.36	68.12	79.04	57.85	87.26	83.55	84.50
25-44	99.96	127.50	89.69	134.23	115.39	134.44	66.42	77.85	56.15	86.33	81.85	84.54
25-43	79.64	110.32	69.37	100.05	88.06	118.74	70.22	85.52	59.95	93.94	59.95	93.94
25-46	81.94	105.78	71.67	95.51	90.36	114.20	67.30	77.46	57.03	85.88	57.03	85.88
25-61	76.69	103.44	66.42	93.17	85.11	111.86	68.15	79.04	57.88	87.46	57.88	87.46
25-08	103.02	134.85	92.75	124.58	111.44	143.27	67.02	78.85	56.75	87.27	56.75	87.27
25-20	88.04	118.26	77.77	107.99	96.46	126.68	66.47	76.72	56.20	85.14	56.20	85.14
25-04	80.44	110.29	70.17	100.02	88.86	118.71	71.24	84.85	60.97	93.27	60.97	93.27

Weight in gram

* Please, consult us for weight of receptacles type 77.

JVS Bronze Series



CECC 75.201.00 JVS Bronze Series

JVS Bronze Series



Connector part numbers

Basic series	JVS	16	A	11	35	P	N	**
Shell style:								
00: Square flange receptacle								
07: Jam nut receptacle								
16: Plug with RFI Shielding								
Material:								
A: Bronze housing material.								
Shell size 09 - 11 - 13 - 15 - 17 - 19 - 21 - 23 - 25								
Contact layout: See page 8 to 11								
Contact type:								
P: Pin A: Connector supplied less pin contact or with specific contacts (Connector marking: A+ orientation)								
S: Socket B: Connector supplied less socket contact or with specific contacts (Connector marking: B+ orientation)								
Orientations: N, A, B, C, D & E (See page 58)								
Specification:								
251: Connector provides with power contacts (layouts with contacts #8)								
Cl: Printed board mounting contacts.								
Ll: Receptacle with long spill (pin or socket #22D)								
MW: Wire wrap contacts								
022: Fuel tank								
L: For P or S contact type only, connectors delivered without contacts, connectors marking P or S plus orientation.								

CECC part numbers

Basic series	CECC 75 201-002	B	B98	M	C	N	A	0	1	G
Shell style:										
A: Plug										
B: Square flange receptacle.										
C: Jam nut receptacle.										
Shell size & layout:										
A=09, B=11, C=13, D=15, E=17, F=19, G=21, H=23, J=25										
(B=Shell size 11) (Layouts: see page 8 to 11)										
Contact type:										
M: Pin										
F: Socket										
Type of contact termination:										
C: Crimp contact										
Orientations N, A, B, C, D & E (See page 58)										
Shell material:										
A: Aluminium bronze										
Supply code:										
0= Connectors supplied with contacts										
1= Connectors supplied without contacts										
Assessment level:										
1: Level 1										
Performance level:										
G: Level G										

Example :
Abbreviated version :

C 752 002	B	B98	M	C	N	A	0	1	G
------------------	----------	------------	----------	----------	----------	----------	----------	----------	----------

JVS Bronze Series



Dimensions

Receptacle type 00

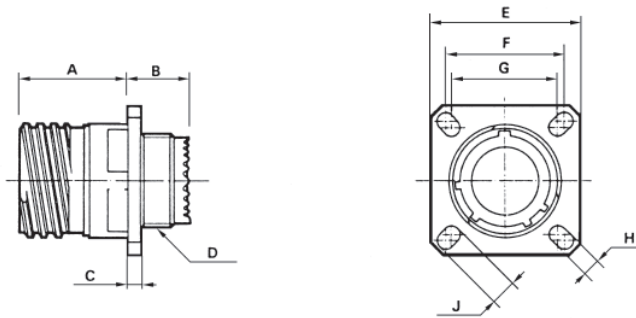

Shell size	A Max.	B Max.	C Max.	D thread	E ± 0,30	F	G	H	J
09 (A)	20.90	10.60	2.50	M12 x 1-6g	23.80	18.26	15.09	3.25	5.49
11 (B)	20.90	10.60	2.50	M15 x 1-6g	26.20	20.62	18.26	3.25	4.93
13 (C)	20.90	10.60	2.50	M18 x 1-6g	28.60	23.01	20.62	3.25	4.93
15 (D)	20.90	10.60	2.50	M22 x 1-6g	31.00	24.61	23.01	3.25	4.93
17 (E)	20.90	10.60	2.50	M25 x 1-6g	33.30	26.97	24.61	3.25	4.93
19 (F)	20.90	10.60	2.50	M28 x 1-6g	36.50	29.36	26.97	3.25	4.93
21 (G)	20.10	11.40	3.20	M31 x 1-6g	39.70	31.75	29.36	3.25	4.93
23 (H)	20.10	11.40	3.20	M34 x 1-6g	42.90	34.93	31.75	3.91	6.15
25 (J)	20.10	11.40	3.20	M37 x 1-6g	46.00	38.10	34.93	3.91	6.15

Receptacle type 07

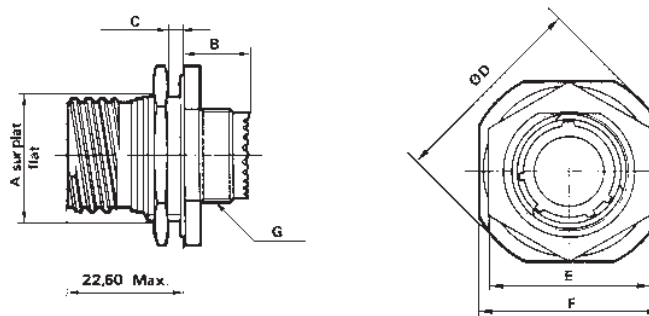

Shell size	A + 0.10 - 0.15	B Max.	C Max.	D Max.	E Max.	F ± 0.4	G thread
09 (A)	16.53	9.90	3.20	30.50	23.00	27.00	M12 x 1-6g
11 (B)	19.07	9.90	3.20	35.20	26.00	31.80	M15 x 1-6g
13 (C)	23.82	9.90	3.20	38.40	31.00	34.90	M18 x 1-6g
15 (D)	26.97	9.90	3.20	41.60	34.00	38.10	M22 x 1-6g
17 (E)	30.15	9.90	3.20	44.80	37.00	41.30	M25 x 1-6g
19 (F)	33.32	9.90	3.20	49.50	41.00	46.00	M28 x 1-6g
21 (G)	36.50	9.90	3.20	52.70	46.00	49.20	M31 x 1-6g
23 (H)	39.67	9.90	3.20	55.90	47.00	52.40	M34 x 1-6g
25 (J)	42.85	9.90	3.20	59.00	52.00	55.60	M37 x 1-6g

Dimensions in millimeters

JVS Bronze Series



Plug type 16

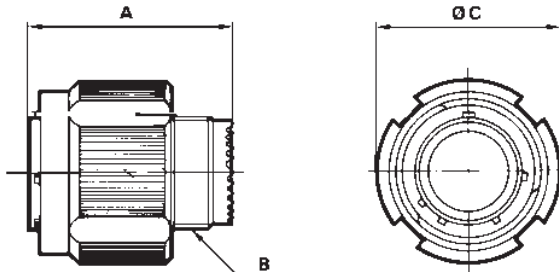

Shell size	A Max.	B thread	C Max.
09 (A)	31.00	M12 x 1-6g	21.10
11 (B)	31.00	M15 x 1-6g	23.80
13 (C)	31.00	M18 x 1-6g	28.20
15 (D)	31.00	M22 x 1-6g	31.40
17 (E)	31.00	M25 x 1-6g	36.50
19 (F)	31.00	M28 x 1-6g	39.30
21 (G)	31.00	M31 x 1-6g	42.50
23 (H)	31.00	M34 x 1-6g	45.30
25 (J)	31.00	M37 x 1-6g	48.40

Maximum coupling torque on panel for jam nut receptacle (type 7)

Shell	09 (A)	11 (B)	13 (C)	15 (D)	17 (E)	19 (F)	21 (G)	23 (H)	25 (J)
Coupling torque (N.m)	6	8	10	13	20	23	25	26	28

Mated connectors dimensions

Type 00 with plug

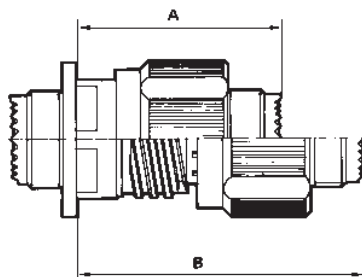

Type 7 with plug

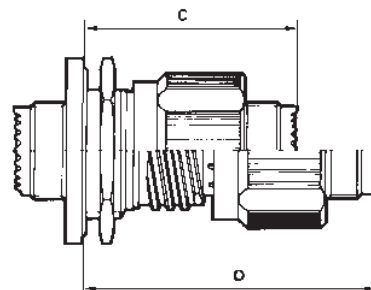

Shell size	A Max.	B Max.	C Max.	D Max.
09 (A)	37.00	52.30	38.30	53.60
11 (B)	37.00	52.30	38.30	53.60
13 (C)	37.00	52.30	38.30	53.60
15 (D)	37.00	52.30	38.30	53.60
17 (E)	37.00	52.30	38.30	53.60
19 (F)	37.00	52.30	38.30	53.60
21 (G)	36.00	51.30	38.30	53.60
23 (H)	36.00	51.30	38.30	53.60
25 (J)	36.00	51.30	38.30	53.60

Dimensions in millimeters

JVS Bronze Series



Receptacle with straight spill contacts

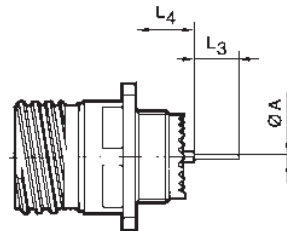
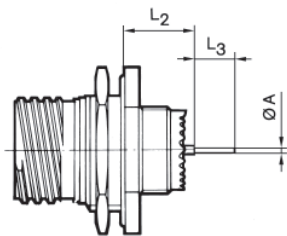

		Shell size			09 (A)	11 (B)	13 (C)	15 (D)	17 (E)	19 (F)	21 (G)	23 (H)	25 (J)
		Contact size	Contact type	Spill type									
A		# 22D	M & F	Li	0.70								
		# 22D	M & F	Ci	0.50								
		# 20	M & F	Ci	0.70								
		# 16	M & F	Ci	1.15								
L2	Min.	# 22D	M	Li	10.52	10.34							
	Max.	# 22D	M	Li	11.46	11.28							
	Min.	# 22D	F	Li	10.19	10.01							
	Max.	# 22D	F	Li	11.46	11.28							
	Min.	# 22D	M	Ci	10.19	10.01							
	Max.	# 22D	M	Ci	11.46	11.28							
	Min.	# 22D	F	Ci	10.69	10.51							
	Max.	# 22D	F	Ci	11.63	11.45							
	Min.	# 20	M	Ci	10.36	10.18							
	Max.	# 20	M	Ci	11.63	11.45							
	Min.	# 20	F	Ci	10.69	10.51							
	Max.	# 20	F	Ci	11.63	11.45							
	Min.	# 16	M	Ci	10.69	10.51							
	Max.	# 16	M	Ci	11.63	11.45							
	Min.	# 16	F	Ci	10.69	10.51							
	Max.	# 16	F	Ci	11.63	11.45							
L3		# 22D	M & F	Li	8.50								
		# 22D	M & F	Ci	5.10								
		# 20	M & F	Ci	5.10								
		# 16	M & F	Ci	5.10								
L4	Min.	# 22D	M	Li	9.48								
	Max.	# 22D	M	Li	10.58						10.69		
	Min.	# 22D	F	Li	9.15						9.26		
	Max.	# 22D	F	Li	10.58						10.69		
	Min.	# 22D	M	Ci	9.65						9.76		
	Max.	# 22D	M	Ci	10.75						10.86		
	Min.	# 22D	F	Ci	9.15						9.26		
	Max.	# 22D	F	Ci	10.75						10.86		
	Min.	# 20	M	Ci	9.65						9.76		
	Max.	# 20	M	Ci	10.75						10.86		
	Min.	# 20	F	Ci	9.65						9.76		
	Max.	# 20	F	Ci	10.75						10.86		
	Min.	# 16	M	Ci	9.65						9.76		
	Max.	# 16	M	Ci	10.75						10.86		
	Min.	# 16	F	Ci	9.65						9.76		
	Max.	# 16	F	Ci	10.75						10.86		

M: Male contact F: Female contact Ci: Short spill Li: Long spill

Dimensions in millimeters

JVS Bronze Series



Bronze backshell part numbers (JVS)

Basic series	JVS	A	09	B	00	A
Accessory style:						
A: Rear accessories (backshells)						
Shell size:						
09 - 11 - 13 - 15 - 17 - 19 - 21 - 23 - 25						
Accessory variant:						
B, C, P, X (See below)						
Sub variant:						
Not applicable: 00						
Matière:						
A: Bronze						

Straight cable clamp (type B)

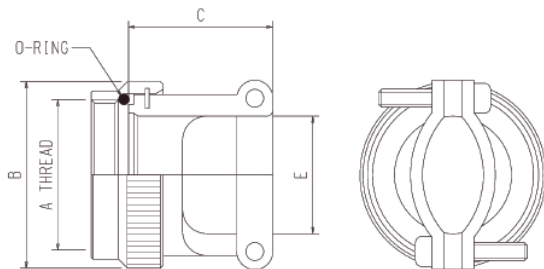

Shell size	A Thread	B Max.	C Max.	E Max.
09	M12 x 1.0	18.0	21.5	7.0
11	M15 x 1.0	21.0	21.5	10.5
13	M18 x 1.0	24.5	23.5	13.4
15	M22 x 1.0	27.5	23.5	16.5
17	M25 x 1.0	31.0	24.5	19.7
19	M28 x 1.0	34.0	27.5	22.2
21	M31 x 1.0	37.0	34.5	25.6
23	M34 x 1.0	40.0	37.5	28.5
25	M37 x 1.0	43.5	37.5	31.7

90° cable clamp (type C)

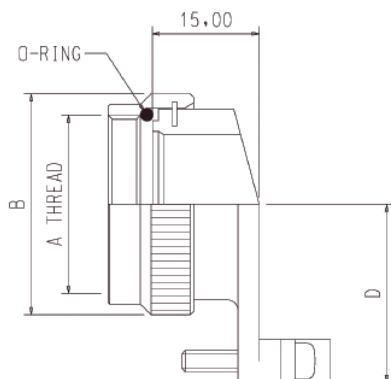

Shell size	A Thread	B Max.	D Max.
09	M12 x 1.0	18.0	20.00
11	M15 x 1.0	21.0	21.0
13	M18 x 1.0	24.5	22.0
15	M22 x 1.0	27.5	23.0
17	M25 x 1.0	31.0	25.0
19	M28 x 1.0	34.0	27.5
21	M31 x 1.0	37.0	30.0
23	M34 x 1.0	40.0	31.5
25	M37 x 1.0	43.5	34.5

Dimensions in millimeters

JVS Bronze Series



Backshell for heat shrink boot (type P)

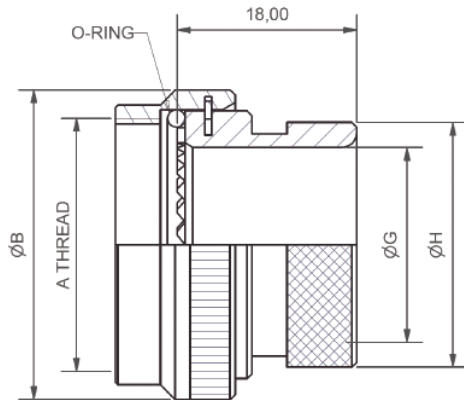

Shell size	A Thread	B Max.	G Max.	H Max.
09	M12 x 1.0	18.0	7.0	13.5
11	M15 x 1.0	21.0	10.5	15.4
13	M18 x 1.0	24.5	13.8	19.7
15	M22 x 1.0	29.0	16.5	21.3
17	M25 x 1.0	32.5	19.7	24.5
19	M28 x 1.0	35.5	22.1	26.5
21	M31 x 1.0	37.0	25.4	31.0
23	M34 x 1.0	40.0	28.5	34.4
25	M37 x 1.0	43.5	31.7	36.6

Screened adaptor with cone screen clamp (type X)

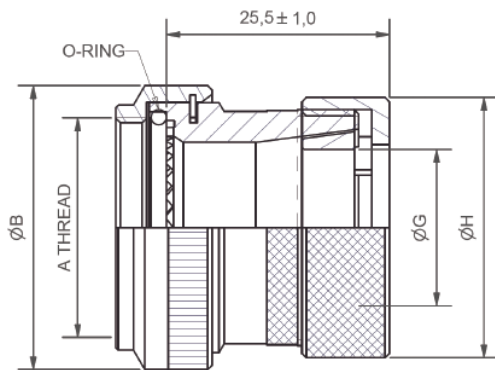

Shell size	A Thread	B Max.	G	H Max.
09	M12 x 1.0	18.0	6.8	16.0
11	M15 x 1.0	21.0	9.5	19.0
13	M18 x 1.0	24.5	12.8	22.0
15	M22 x 1.0	29.0	14.8	25.4
17	M25 x 1.0	32.5	17.9	28.5
19	M28 x 1.0	35.5	20.0	32.0
21	M31 x 1.0	37.0	23.0	35.0
23	M34 x 1.0	40.0	26.4	38.0
25	M37 x 1.0	43.5	29.3	41.0

JVS Bronze Series



Caps for bronze connectors (JVS)

Basic series	JVS	B	09	B	00	A
Accessory style: B: Protective cap						
Shell size: 09 - 11 - 13 - 15 - 17 - 19 - 21 - 23 - 25						
Cap type: A or B: Cap for plug (See drawing below) C or D: Cap for receptacle (See drawing below)						
Sub variant: Not applicable						
Matière: A: Bronze						

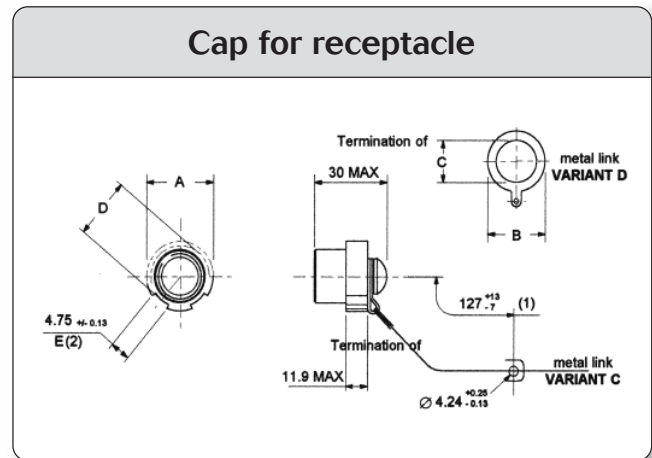
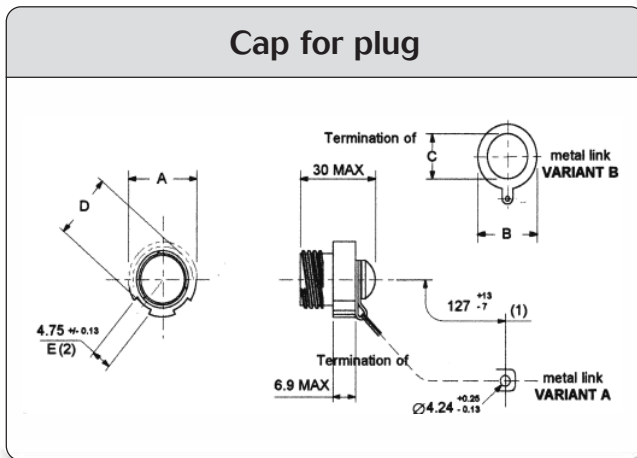

- (1) Flexible metal link
- (2) Number of notch on A diameter

Shell size	A Max.	Variant B B Max.	Variant B C Min.	Variant D B Max.	Variant D C Min.	D Max.	E
09	21.1	24.20	13.50	26.80	18.40	19.20	8
11	23.8	26.80	18.40	31.60	23.00	21.80	
13	28.2	30.50	19.80	36.90	26.20	26.10	10
15	31.4	31.60	23.00	40.10	29.40	29.30	
17	36.5	36.90	26.20	43.20	32.50	34.40	12
19	39.3	40.10	29.40	46.40	35.70	37.20	
21	42.5	43.20	32.50	49.20	39.10	40.50	16
23	45.3	46.40	35.70	52.80	42.10	43.10	
25	48.4	49.20	39.10	55.50	45.30	46.10	18

Dimensions in millimeters

Common section



Summary

Orientations	58
Panel cut-out	59
Gaskets	59
Crimp contacts	60
Straight spill contacts	62
Plastic protective caps	62
Wire wrap contacts	63
Thermocouple contacts	63
Crimping tools	64
Insertion & extraction tools / Filler plug	64
Wiring instruction	65

Common section



Orientations

Viewed from face of receptacle

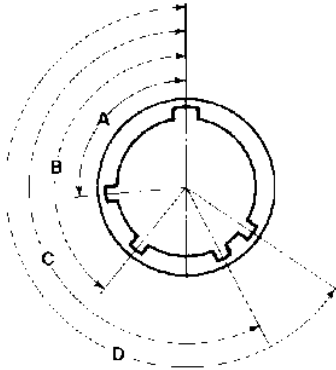

Viewed from front of plug

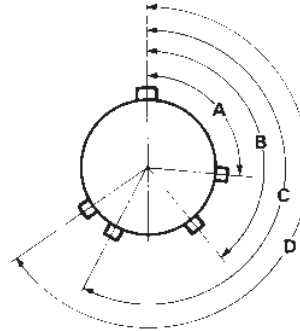

Contact size	Angles	N	A	B	C	D	E
09 (A)	A°	105	102	80	35	64	91
	B°	140	132	118	140	155	131
	C°	215	248	230	205	234	197
	D°	265	320	312	275	304	240
11 (B)	A°	95	113	90	53	119	51
	B°	141	156	145	156	146	141
	C°	208	182	195	220	176	184
	D°	236	292	252	255	298	242
13 (C)	A°	95	113	90	53	119	51
	B°	141	156	145	156	146	141
	C°	208	182	195	220	176	184
	D°	236	292	252	255	298	242
15 (D)	A°	95	113	90	53	119	51
	B°	141	156	145	156	146	141
	C°	208	182	195	220	176	184
	D°	236	292	252	255	298	242
17 (E)	A°	80	135	49	66	62	79
	B°	142	170	169	140	145	153
	C°	196	200	200	200	180	197
	D°	293	310	244	257	280	272
19 (F)	A°	80	135	49	66	62	79
	B°	142	170	169	140	145	153
	C°	196	200	200	200	180	197
	D°	293	310	244	257	280	272
21 (G)	A°	80	135	49	66	62	79
	B°	142	170	169	140	145	153
	C°	196	200	200	200	180	197
	D°	293	310	244	257	280	272
23 (H)	A°	80	135	49	66	62	79
	B°	142	170	169	140	145	153
	C°	196	200	200	200	180	197
	D°	293	310	244	257	280	272
25 (J)	A°	80	135	49	66	62	79
	B°	142	170	169	140	145	153
	C°	196	200	200	200	180	197
	D°	293	310	244	257	280	272

Common section



Panel cut-out

Square flange receptacle (type 0)

Jam nut receptacle (type 7)

Shell size	9 (A)	11 (B)	13 (C)	15 (D)	17 (E)	19 (F)	21 (G)	23 (H)	25 (J)
A	18.26	20.62	23.01	24.61	26.97	29.36	31.75	34.93	38.10
G	15.09	18.26	20.62	23.01	24.61	26.97	29.36	31.75	34.94
B min.	16.66	20.22	23.42	26.59	30.96	32.94	36.12	39.29	42.47
C ± 0.13	3.25	3.25	3.25	3.25	3.25	3.25	3.25	3.91	3.91
D min.	13.11	15.88	19.05	23.01	25.81	28.98	32.16	34.93	37.69
E + 0.25	17.78	20.96	25.65	28.83	32.01	35.18	38.35	41.53	44.70
F 0	17.02	19.59	24.26	27.56	30.73	33.91	37.08	40.26	43.43

Max. thickness panel for square flange receptacle - type 0: front mounting : 3,2 mm Max. - Rear mounting: 2,5 mm Max.

(Dimensions in millimeters).

Gaskets









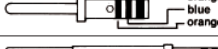

Shell size	Part numbers	
	Gasket for receptacles type 0* (ordered separately)	O ring for receptacle type 7
09 (A)	8599-5541	AS3582-019
11 (B)	8599-5542	AS3582-022
13 (C)	8599-5543	AS3582-024
15 (D)	8599-5544	AS3582-026
17 (E)	8599-5545	AS3582-028
19 (F)	8599-5546	AS3582-128
21 (G)	8599-5547	AS3582-130
23 (H)	8599-5548	AS3582-132
25 (J)	8599-5549	AS3582-134

* For rear mounting

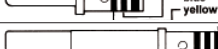
Common section

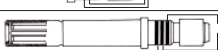

Crimp contact

Contact size	Contact type	Souriau P/N (without colour code)	MIL-DTL-38999 Contacts		
			Part number	Profile and colour code	
#22D	Pin	8599-0702 JJ	M39029/58 360		
	Socket	8599-0706 900	M39029/56 348		
#20	Pin	8599-0703 SA	M39029/58 363		
	Socket	8599-0707 900	M39029/56 351		
#16	Pin	8599-0704 MJ	M39029/58 364		
	Socket	8599-0708 900	M39029/56 352		
#16 Coaxial	Pin	-	M39029/76 424		
	Socket	-	M39029/77 428		
#12	Pin	8599-0705 MJ	M39029/58 365		
	Socket	8599-0709 900	M39029/56 353		
#12 Coaxial	Pin	-	M39029/102 558		
	Socket	-	M39029/103 559		
	Pin	-	M39029/28 211		
	Socket	-	M39029/75 416		
#10 Power	Pin	-	M39029/58 528		
	Socket	-	M39029/56 527		
#8 Power	Pin	8599-7544	-		
	Socket	8599-7541	-		
	Boot	8599-4542	-		For wire #8
		8599-4547	-		For wire #10
Reductor	8599-7645	-			
#8 Coaxial	Pin	-	M39029/60 367		
	Socket	-	M39029/59 366		
	Boot	8590-4571	-		
#8 Triaxial	Pin	-	M39029/90 529		
	Socket	-	M39029/91 530		
	Boot	8590-4571	-		
#4 Power	Pin	8599-7598 900*	-		
	Socket	8599-7599 900*	-	For wire 25 mm ²	
	Pin	8599-7534	-		
	Socket	8599-7535	-	For wire 21.15 mm ²	
	Boot	for Cable 16 mm ²	8599-4594	-	
		for Cable 10 mm ²	8599-4593	-	
Reductor Cable 10 mm ²	8400-2352A	-			
#4 Power with reduced barrel	Pin	8599-7528 900	-		
	Socket	8599 7529 900	-	Mating part #4 / Barrel #6	
	Boot	8599-4593	-		

* Not included in connector P/N. Must be ordered separately.

Common section



Crimp contact

Contact size	Contact type	Contact Ø	Conductor section				External Ø over insulator		
			AWG		mm ²		min	max	
			min	max	min	max			
#22D	Pin	0.76	28	22	0.095	0.34	0.76	1.37	
	Socket								
#20	Pin	1.00	24	20	0.21	0.60	1.02	2.11	
	Socket								
#16	Pin	1.60	20	16	0.60	1.34	1.65	2.77	
	Socket								
#16 Coaxial	Pin	1.60	RG 174				1.65	2.60	
	Socket		RG 179 RG 316						
#12	Pin	2.40	14	12	1.91	3.18	2.46	3.61	
	Socket								
#12 Coaxial	Pin	2.40	RG 174				2.40	2.60	
	Socket		RG 179						
	Pin		RG 316						
	Socket								
#10 Power	Pin	3.20	Please consult us				-	2.95	
	Socket								
#8 Power	Pin	3.64	-	8	-	8.98	-	-	
	Socket		-	-	-	-	4.50	6.5	
	Boot		-	-	-	-	2.50	4	
	Reductor		-	-	-	-	-	-	
#8 Coaxial	Pin	3.64	RG 188 A/U				-	2.80	
	Socket								
	Boot								
#8 Triaxial	Pin	5.50	0,76MIL-C17/176 00002				3.15	3.40	
	Socket		FILECA F.2703/14						
	Boot		RAYCHEM CHEMINAX 10612 FILOTEX M 17/176 00002						
#4 Power	Pin	5.74	-	(3)	-	25	-	-	
	Socket		5	4	16	21.15	-	-	
	Pin		-	-	-	-	6.35	7.50	
	Socket		-	-	-	-	4	5.8	
	Boot		Available for 8599-7534 and 7535 contacts	-	-	-	-	-	-
	Reductor Cable 10 mm		-	-	-	-	-	-	-
#4 Power with reduced barrel	Pin	5.74	6		13.3		-	-	
	Socket		-		-		4	5.80	
	Boot		-		-		-	-	

Common section



Straight spill contacts

Contact size	Contact type	Spill type	Part number	Profile
# 22D	Pin	L	8599 - 0720 900	
	Pin	M	8599 - 8018 JJ	
	Pin	C	8599 - 0730 900	
	Pin	C	8599 - 0796 900	
	Socket	L	8599 - 0721 900	
	Pin	M	8599 - 8028 900	
	Socket	C	8599 - 0731 900	
	Socket	S	8599 - 0797 900	
# 20	Pin	M	8599 - 0658 JJ	
	Socket	M	8599 - 0759 900	
	Pin	C	8599 - 0724 900	
	Socket	C	8599 - 0725 900	
	Pin	L	8599 - 0771 900	
	Socket	L	8599 - 0772 900	
# 16	Pin	C	8599 - 0726 900	
	Socket	C	8599 - 0727 900	
Contact coaxial # 16	Pin	C	8599 - 1000 900	
# 12	Pin	C	8599 - 7929 900	
	Socket	C	8599 - 7932 900	

S: Specific spill L: Long spill C: Short spill M: Medium spill

Plastic protective caps*

Shell size	Part numbers		
	Caps for receptacles	Caps for plugs	Caps for composite plugs only(J and M)
9 (A)	70777	8500-5587 A	70205
11 (B)	70205	70198	8500-5598
13 (C)	70206	8500-5600	8500-5600
15 (D)	70207	8500-5601	8500-5601
17 (E)	70201	8500-5602	8500-5602
19 (F)	70209	8500-5592 A	8500-5592 A
21 (G)	70210	8500-5593 A	8500-5593 A
23 (H)	70211	8500-5593 A	70472
25 (J)	8500-5593 A	J599ABC6009A00	J599ABC6009A00

*Excepted 8D composite version (X): supplied without cap

Common section



Crimp contacts: 1500 mating

Contact size	MIL-DTL-38999 contacts		
	Contact type	Part number	Profile and colour code
#22 D	Pin (H)	M39029/107 620	Blue - Red - Black
	Socket (J)	M39029/106 614	Blue - Brown - Yellow
#20	Pin (H)	M39029/107 621	Blue - Red - Brown
	Socket (J)	M39029/106 615	Blue - Brown - Green
#16	Pin (H)	M39029/107 622	Blue - Red - Red
	Socket (J)	M39029/106 616	Blue - Brown - Blue
#12	Pin (H)	M39029/107 623	Blue - Red - orange
	Socket (J)	M39029/106 617	Blue - Brown - Gray

Wire wrap contact

Contact size	Contact type	Part number	Profile
# 22D	Pin	8599 - 0790 JJ	
# 20	Pin	8599 - 0791 900	

Contact size	Contact type	Contact Ø (mm)	mm
# 22D	Pin	0.76	0.86
# 20	Pin	1	0.86

Thermocouple contacts

Contact size	Contact type	Souriau part numbers (without color code)	MIL-DTL-38999 contacts	
			Part numbers	Profile and colour code
# 22 D Chromel	Pin	-	M39029/87-472	
	Socket	-	M39029/88-484	
# 22 D Alumel	Pin	-	M39029/87-471	
	Socket	-	M39029/88-483	
# 20 Chromel	Pin	8599-0749 900	8599-0949 900	
	Socket	8599-0753 900	8599-0953 900	
# 20 Alumel	Pin	8599-0761 900	8599-0961 900	
	Socket	8599-0765 900	8599-0965 900	

Contact size	Ø Contact (mm)	Wire section				Ø Over insulation mm		
		min	Awg	max	min	mm ²	max	
# 22 D Chromel Alumel	0.75	28		22	0.095	0.34	0.76	1.37
# 20 Chromel Alumel	1	24		20	0.21	0.6	1.02	2.11

Common section



Crimping tools

Contact size	Contact type	Pliers						
		M22520/1-01 (Souriau 8365) Turret part number		M22520/2-01 (Souriau 8476-01) Locator part number		M300 BT Locator part number	M22520/23-01	
		Norme	Souriau	Norme	Souriau		Turret part number	Locator part number
# 22D	Pin	-	-	M22520/2-09	8476-09	-	-	-
	Socket	-	-	M22520/2-07	8476-07	-	-	-
# 20	Pin	M22520/1-04	8365-04	M22520/2-10	8476-10	-	-	-
	Socket				8476-10	-	-	-
# 16	Pin	M22520/1-04	8365-04	-	-	-	-	-
	Socket			-	-	-	-	-
# 12	Pin	M22520/1-04	8365-04	-	-	-	-	-
	Socket			-	-	-	-	-
# 8	Pin	-	-	-	-	SP 593	M22520/23-02	8599-9601
Power	Socket	-	-	-	-			
# 4	Pin	-	-	-	-	-	M22520/23-04	M22520/23-11
Power	Socket	-	-	-	-	-		

Contact size	Contact type	Pliers		
		M22520/2-01 (Souriau 8476-01) Locator part number	M22520/4-01 Locator part number	M22520/5-01 Locator part number
# 12	Inner	-	-	M22520/5-03
Coaxial	Outer	-	-	
# 16	Inner	M22520/2-35	-	-
	Coaxial	Outer	-	M22520/4-02
# 8	Inner	M22520/2-31	-	-
	Coaxial	Outer	-	M22520/5-05
# 8	Inner	K709	-	-
	Middle	-	-	Y631 closure B
	Ferrule	-	-	Y631 closure A

* Pneumatic pliers

Nota: for the #10 contact's plier and locator, please consult us.

Insertion and extraction tools & Filler plugs

Contact size	Material	Part number		Insertion/extraction tools		Filter plugs	
		Spec	Souriau	Insertion	Extraction	Part number	Color
# 22D	Plastic	M81969/14-01	-	Green	White	MS27488-22	Black
# 20	Plastic	M81969/14-10	-	Red	Orange	MS27488-20	Red
# 16	Plastic	M81969/14-03	-	Blue	-	MS27488-16	Blue
# 12	Plastic	M81969/14-04	-	Yellow	White	MS27488-12	Yellow
# 10	Plastic	M81969/14-05	-	Grey	-	-	-
	Plastic	M81969/14-12	-	-	Red	-	-
# 8	Metallic	-	8660-197	-	-	-	-
	Plastic	M81969/14-07	-	-	Blue	-	-
# 4	Plastic	-	8533-8175	-	-	-	-
	Metallic	-	-	-	-	-	-

Dummy contact size 8

Part number: 8599-0308

Dummy contact size 4

Part number: 8599-0310

Filler plugs

Direction of introduction in grommet





Wiring instruction

Cable preparation and wire stripping

Contact size	L min.	L Max.
# 22D	3,58 .14	3,99 .16
# 20	5,31 .21	5,82 .23
# 16	5,31 .21	5,82 .23
# 12	5,31 .21	5,82 .23
# 8	12,5 .49	13 .51
# 4	12,5 .49	13 .51

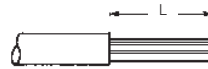

L = Length of wire stripping

Insertion of wire in contact barrel

When inserting the stripped wire into the contact barrel check that no strands are left outside and that the wire is visible through the wire inspection hole in the barrel.

Important:

- Slide any accessories over wire strands before carrying out the following operations.
- Contacts are inserted and extracted from the rear of the connector.

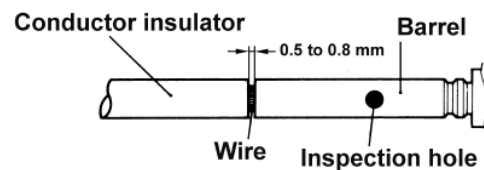

Insertion of the contacts

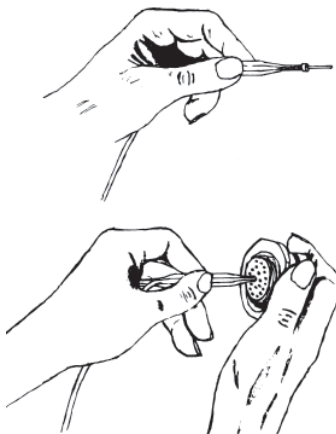

① Engage the crimp cable/contact assembly into the longitudinal slot of the plastic tool (coloured tip). Slide the tool down the cable until the tip of the tool touches the contact retention shoulder.

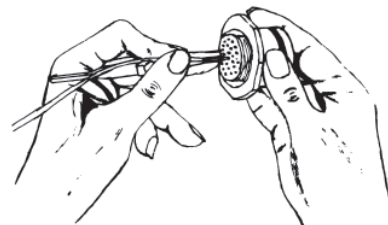

② Introduce the contact into the required contact cavity in the insulator, pushing tool axially, until the contact snaps into position in clip.

③ Withdraw the tool (from rear). Check that the contact is firmly locked by pulling wire gently. When connector is fully loaded, check the position of contact tips. They should all be in the same plane.

Nota: For larger sizes of cable which are stiff enough manual insertion without tool is preferable.

Common section



Extraction of the contacts

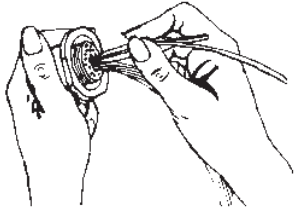

- 1 Engage the appropriate cable into the longitudinal slot of the tool with the white tip towards connector.

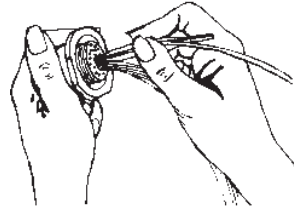

- 2 Slide the tool down towards the contact. Insert the tool in the insulator until it touches the contact shoulder.

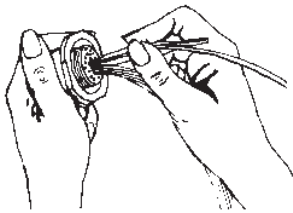

- 3 Holding the tool-contact and cable assembly together, remove them simultaneously.

Backshell tightening and slackening tools

Backshell tightening pliers, part number: 8498-03

Square jaws, part number: 8500-1015 (order 2 jaws).

Strap clamp, part number: 8498-04

Spare strap, part number: 8498-103

8498-03

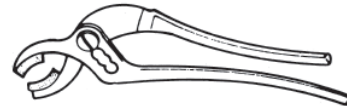

8498-04

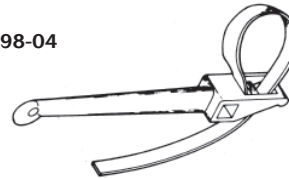

Tightening support

Part number: 8599-0831

This tool is made up of dummy receptacle housings of all 9 sizes for all key polarisation, and locates free connectors during wiring and fitting of rear accessories.

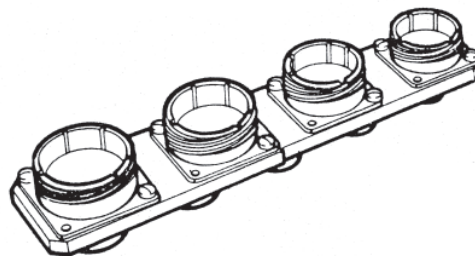

8D-JVS Series with quadrax contacts

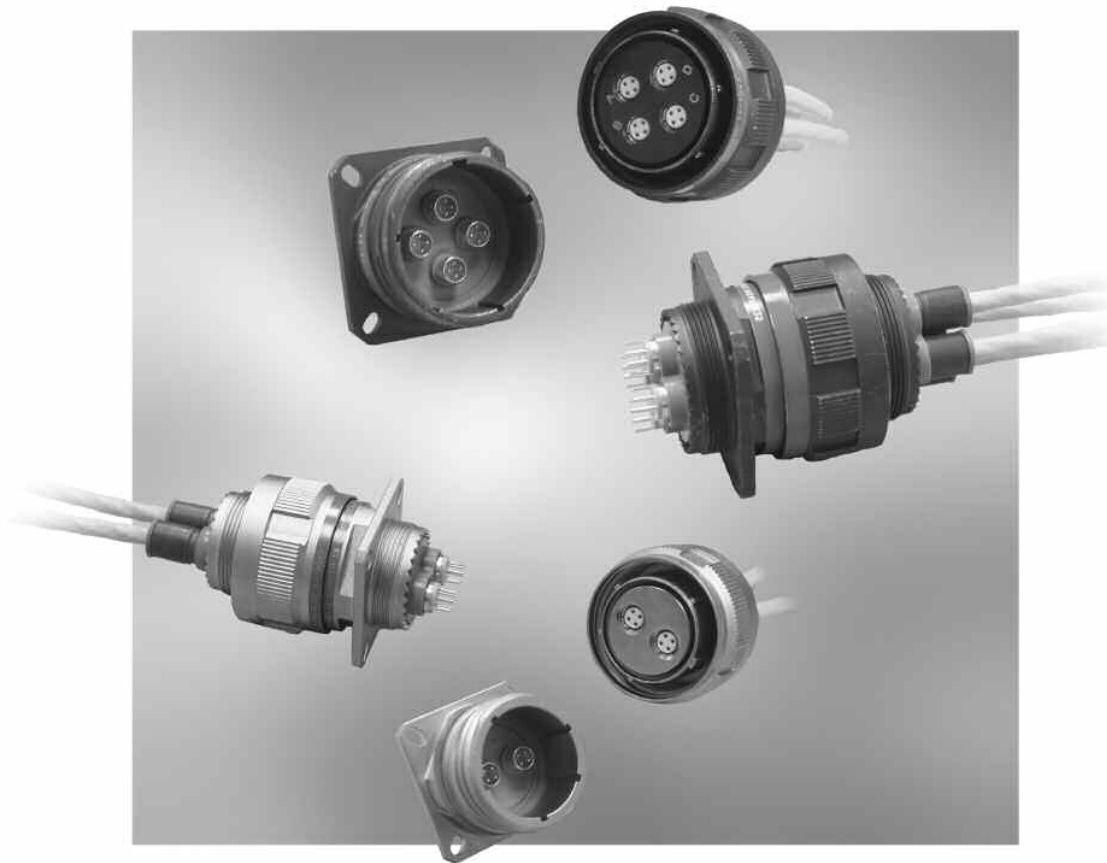

Derived from:
MIL-DTL-38999 Serie III

8D-JVS Series with quadrax contacts



Description

- Size 8 outer contact with 4 #24 inner contacts forming two 100 or 150 matched impedance pairs with excellent 360° shielding.
- Replace 2 twinax contacts with:
 - better performances (reduced cross talk)
 - shorter cabling time
 - compact profile, lighter weight
- One contact complete a full duplex 100 mbps ethernet link
- Ground connection of the cable braid possibility trough electrical continuity with the connector shell
- Standard 38999 shells and inserts

Characteristics

Applications

- Quadrax connector for network applications in severe climatic and/or mechanical environments.

Mechanical

See page 6

Climatics

See page 7

Contact	Rated current (A)	Max contact resistance (mΩ)		
		23°C		200°C
		Initial	After tests	After tests
Signal contacts	1	15	30	45
Outer body	12	3	4	6

Electrical

- **ISO/IEC 11801 category 6 compliant:**
 - Next (Cross talk): > 46 dB at 250 MHz
 - Return loss: > 16 dB at 250 MHz
 - Shield effectiveness: > 36 dB at 250 MHz
- **Contact to shell continuity: 10 mΩ max.**
- **Contact resistance (low level):**
 - Initial: 15 mΩ
 - After tests: 30 mΩ

- **Test voltage rating:**
 - Sea level: 500 Vrms
 - At 21000 m = 125 Vrms
- **Insulation resistance: > 5000 mΩ**
- **# 24 contact for cable wire:**
AWG 22 à / to AWG 26

Mechanical :

- **Operating temperature:** -65°C to +200°C
- **# 24 contacts:** copper alloy
- **Contact # 8 body:** copper alloy
- **Insulator:** thermoplastic
- **Contact plating:** Gold over nickel

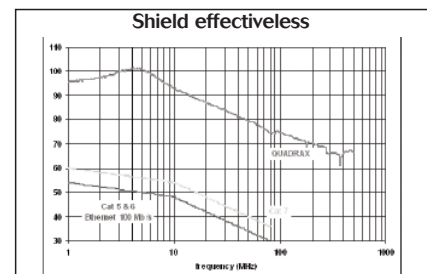
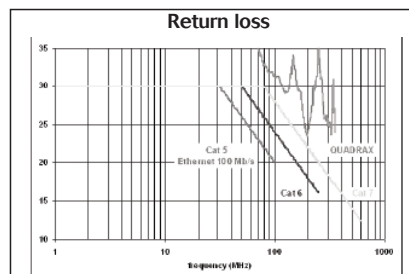
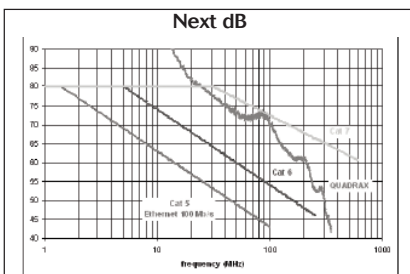

8D-JVS Series with quadrax contacts



Connector part numbers

Basic Series	8D	0	C	11	W	81	P	N	284
Shell style:									
<ul style="list-style-type: none"> 0: Square flange receptacle 7: Jam nut receptacle 5: Plug 									
Type:									
<ul style="list-style-type: none"> C: Receptacle with Quadrax PC tail contacts* Q: Connectors with Quadrax crimp contacts 									
Shell size: 11 - 17 - 21 - 25									
Plating:									
<ul style="list-style-type: none"> W: Olive green cadmium (aluminium) F: Nickel (aluminium) K: Passivated (stainless steel) S: Nickel (stainless steel) J: Olive green cadmium (composite) M: Nickel (composite) X: Without plating (composite) TF: Nickel (Titanium) TT: Without plating (Titanium) 									
Contact layout: See page 8 to 11									
Contact type:									
<ul style="list-style-type: none"> P: Pin A: Connector supplied less pin contact S: Socket B: Connector supplied less socket contact 									
Orientation: N, A, B, C, D & E (See page 58)									
Specification:									
<ul style="list-style-type: none"> 284: Grounded (cts 100 Ω)* 308: Not grounded (cts 100 Ω) 384: Grounded (cts 150 Ω)* 408: Not grounded (cts 150 Ω) 									

Bronze connectors part numbers

Basic Series	JVS	C	00A	09	35	P	N	284
Shell style:								
<ul style="list-style-type: none"> C: Receptacle with Quadrax PC tail contacts* Q: Connectors with Quadrax crimp contacts 								
Shell style:								
<ul style="list-style-type: none"> 00A: Square flange receptacle 16A: Plug 07A: Jam nut receptacle 								
Shell size: 11 - 17 - 21 - 25								
Contact layout: See page 8 to 11								
Contact type:								
<ul style="list-style-type: none"> P: Pin A: Connector supplied less pin contact S: Femelle B: Connector supplied less socket contact 								
Orientation: N, A, B, C, D & E (See page 58)								
Specification:								
<ul style="list-style-type: none"> 284: Grounded (cts 100 Ω)* 308: Not grounded (cts 100Ω) 384: Grounded (cts 150 Ω)* 408: Not grounded (cts 150 Ω) 								

* Excepted mixte versions (17-81, 25-80, 25-81, 25-82, 25-86)

8D-JVS Series with quadrax contacts



Square flange receptacle – Type 0

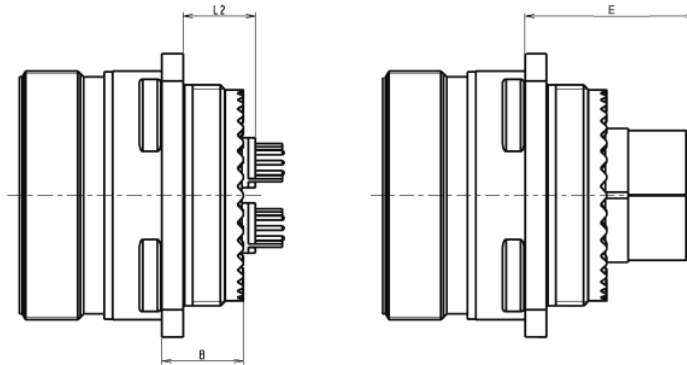

Shell size	PC tail contacts	Contacts to crimp	L2 Max.	L2 Min.
	B Max.	E Max.		
11	37.00	52.30	38.30	53.60
17	37.00	52.30	38.30	53.60
21	36.00	51.30	38.50	53.80
25	36.00	51.30	38.50	53.80

Jam nut receptacle – Type 7

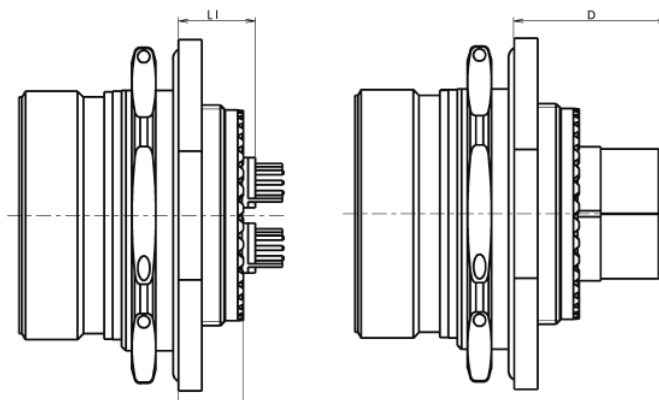

Shell size	PC tail contacts	Contacts to crimp	L1 Max.	L1 Min.
	B Max.	D Max.		
11	9.90	22.40	11.45	10.50
17	9.90	22.20	11.30	10.35
21	9.90	22.20	11.30	10.35
25	9.90	22.20	11.30	10.35

Dimensions in millimeters)

8D-JVS Series with quadrax contacts



Plug - Type 5

Shell size	C max. size.
11	44.00
17	44.00
21	44.00
25	44.00

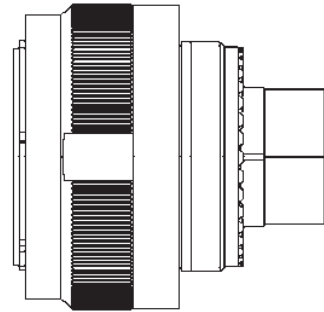

Mated connector - Type 0 & type 5

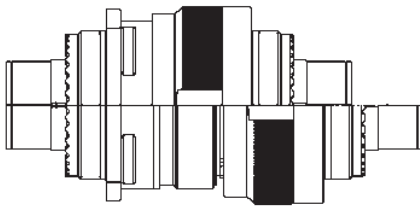

Mated connector - Type 7 & type 5

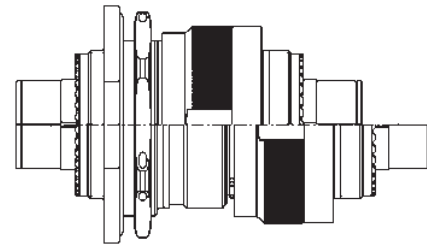

Shell size	B Max.	D Max.	L1 Max.	L1 Min.
11	64.90	66.60	49.60	51.30
17	64.90	66.60	49.60	51.30
21	64.10	66.60	48.80	51.30
25	64.10	66.60	48.80	51.30

Drill dimensions for PCB mount

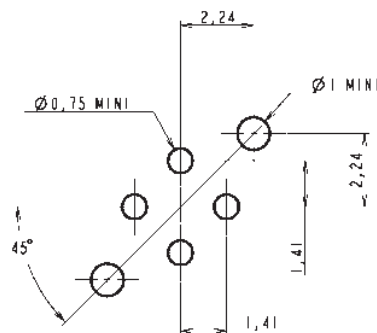

(Dimensions in millimeters)

8D-JVS Series with quadrax contacts



Crimp pin contact

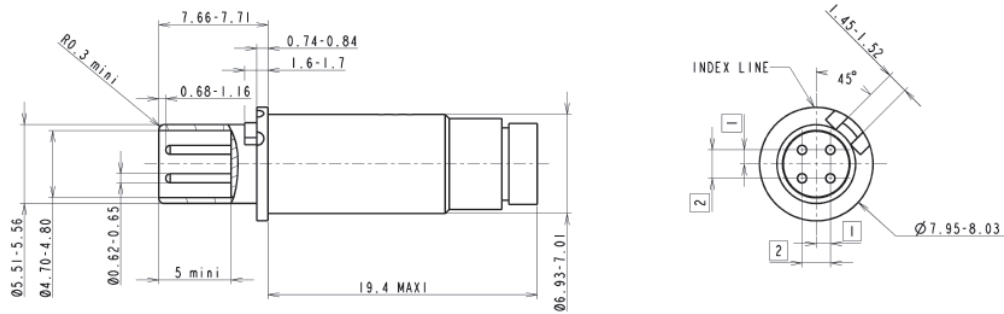

Part number	100 Ω	ETH1-1235 A
	150 Ω	ETH1-1503 A

Crimp socket contact

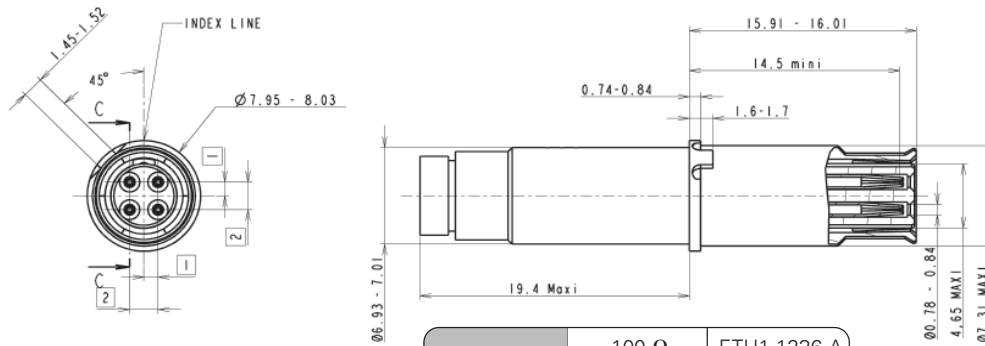

Part number	100 Ω	ETH1-1236 A
	150 Ω	ETH1-1504 A

Pin contact for PCB mount

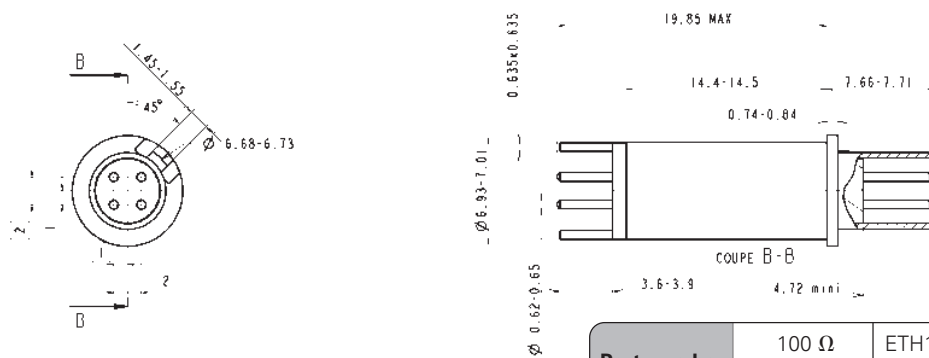

Part number	100 Ω	ETH1-1237 A
	150 Ω	ETH1-1501 A

(Dimensions in millimeters)

8D-JVS Series with quadrax contacts



Socket contact for PCB mount

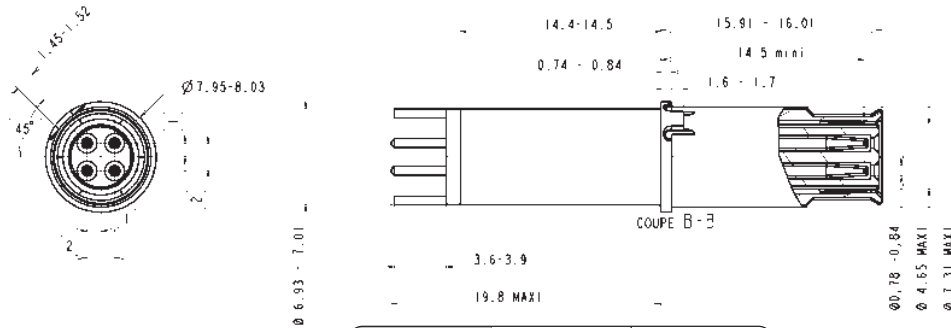

(Dimensions in millimeters)

Tooling

Crimping tools

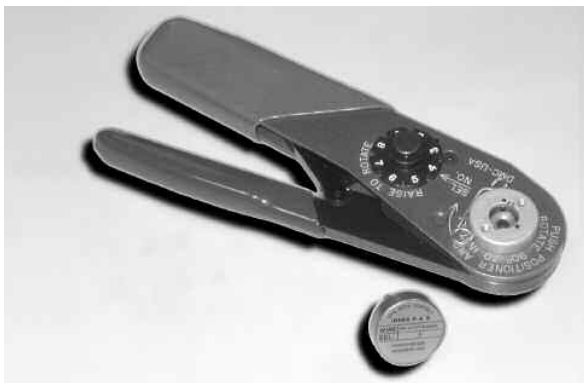

Ref: M22520/2-01 and K709

Insertion and extraction tools



Ref: 8660-197



Ref: M22520/5-01 et / and M22520/5-45B

8D - JVS Series with optical Elio contacts



Derived from:
MIL-DTL-38999 Serie III

8D - JVS Series with optical Elio contacts



Description

- Optical Elio contact qualified according to Arinc 801 EN4531 and ABS1379 fitting in standard 38999 shell with specific inserts.
- Easy insertion and extraction of the contact, without tool (bayonet locking system).
- Individual contact sealing (rear sealing boot integrated on contact).
- Contact easy to clean (no need to remove the contacts, levelling contacts on receptacle side).
- Robust and high vibration with standing solution.

Characteristics

Applications

- Fiber optic connector for industrial, military and aeronautical application in severe climatic or mechanical environment.

Mechanical

- See page 6.

Climatics

- See page 7.

Optical

- Typical insertion loss multimode:
0.3 dB at 1300 nm.
- Typical return loss multimode:
- 30 dB at 1300 nm.
- Maximum IL during and after climatic tests at 1300 nm and 850 nm for multimode
62.5 / 125 fiber: 0.7 dB.

8D - JVS Series with optical Elio contacts



Connector part numbers

Basic series	8D	0	E	11	W	02	A	N
Shell style:								
<ul style="list-style-type: none"> 0: Square flange receptacle (Female insert B only) 7: Jam nut receptacle (Excepted composite version) (Female insert B only) 5: Plug with RFI shielding (Male insert A only) 								
Designation:								
<ul style="list-style-type: none"> E: ELIO™ optical connector 								
Shell size: 09 - 11 - 13 - 19 - 25								
Plating:								
<ul style="list-style-type: none"> W: Olive green cadmium (aluminium) F: Nickel (aluminium) K: Passivated (stainless steel) S: Nickel (stainless steel) J: Olive green cadmium (composite) M: Nickel (composite) X: Without protection (composite) TF: Nickel plated (Titanium) TT: Unplated (Titanium) 								
Contact layout:								
See page 8 to 11)								
Insert type:								
<ul style="list-style-type: none"> A: Male insert (plug) B: Female insert with ceramic alignment sleeves (receptacle) 								
Orientation: N, A, B, C, D & E (See page 58)								

Connector part numbers Bronze

Basic series	JVS	E	0	A	11	02	A	N
Designation:								
<ul style="list-style-type: none"> E: ELIO™ connecteur optique / optical connector 								
Shell style:								
<ul style="list-style-type: none"> 0: Square flange receptacle (Female insert B only) 7: Jam nut receptacle (Female insert B only) 6: Plug with RFI shielding (Male insert A only) 								
Material:								
<ul style="list-style-type: none"> A: Bronze 								
Shell size: 09 - 11 - 13 - 19 - 25								
Insert arrangement: (see page 8 to 11)								
Insert type:								
<ul style="list-style-type: none"> A: Male insert (plug) B: Female insert with ceramic alignment sleeves (receptacle) 								
Orientation: N, A, B, C, D & E (See page 58)								

8D - JVS Series with optical Elio contacts



Receptacle type 0

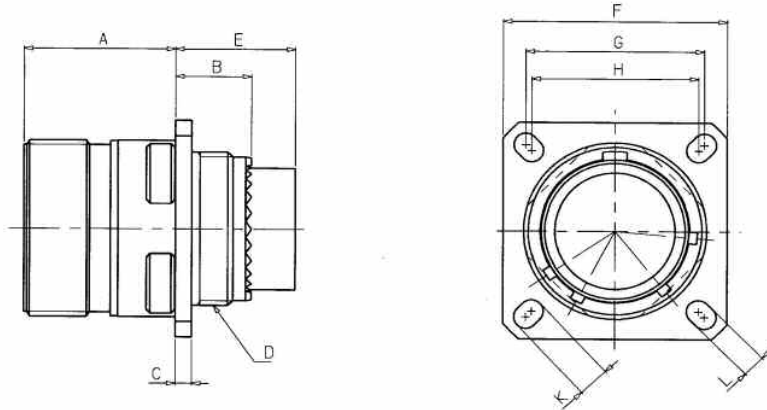

Shell size	A Max.	B Max.	C Max.	D thread	E Max.	F ± 0.30	G	H	K ± 0.20	L ± 0.20
09	20.90	10.60	2.50	M12 x 1-6g	17.10	23.80	18.30	15.10	5.50	3.25
11	20.90	10.60	2.50	M15 x 1-6g	17.10	26.20	20.62	18.26	4.93	3.25
13	20.90	10.60	2.50	M18 x 1-6g	17.10	28.60	23.01	20.62	4.93	3.25
19	20.90	11.60	2.50	M28 x 1-6g	17.10	36.50	29.36	26.97	4.93	3.25
25	20.10	11.40	3.20	M37 x 1-6g	17.90	46.00	38.10	34.93	6.15	3.25

Receptacle type 7

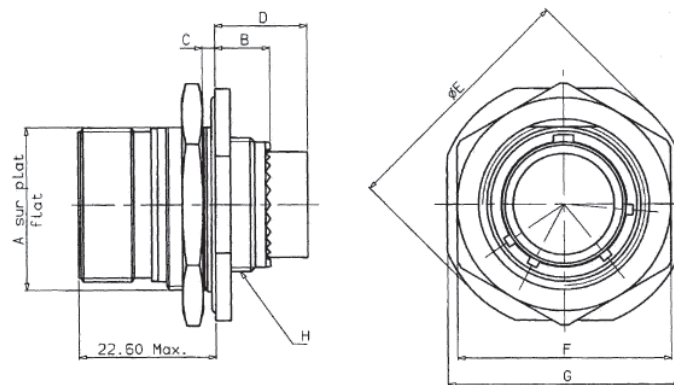

Shell size	A Max.	B Max.	C Max.	D Max.	E Max.	F Max.	G ± 0.40	H Thread
09	16.55	9.90	3.20	16.40	32.50	23.00	27.00	M12 x 1-6g
11	19.07	9.90	3.20	16.40	35.20	27.00	31.80	M15 x 1-6g
13	23.82	9.90	3.20	16.40	38.40	32.00	34.90	M18 x 1-6g
19	33.32	9.90	3.50	16.40	49.50	41.00	46.00	M28 x 1-6g
25	42.85	9.90	3.50	16.40	59.00	55.60	55.60	M37 x 1-6g

Dimensions in millimeters

8D - JVS Series with optical Elio contacts



Plug type 5

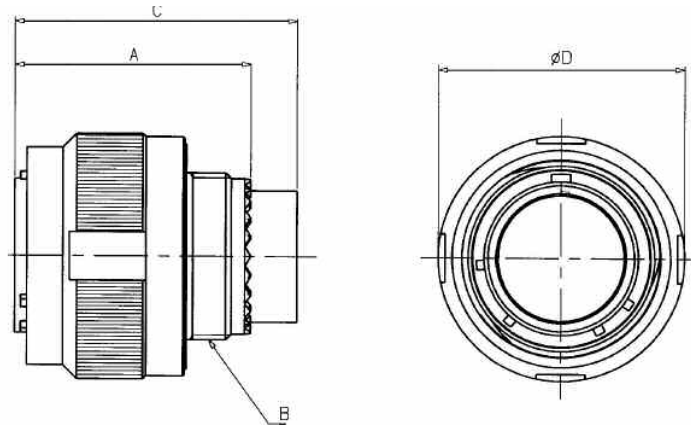

Shell size	A Max.	B Thread	C Max.	D Max.
09	31.00	M12 x 1-6g	37.50	21.80
11	31.00	M15 x 1-6g	37.50	25.00
13	31.00	M18 x 1-6g	37.50	29.40
19	31.00	M18 x 1-6g	37.50	38.50
25	31.00	M37 x 1-6g	37.50	48.00

Mated connectors dimensions

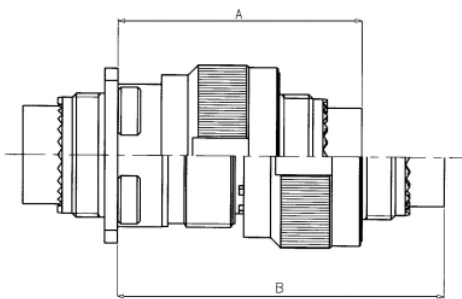

Square flange receptacle type 0 with plug

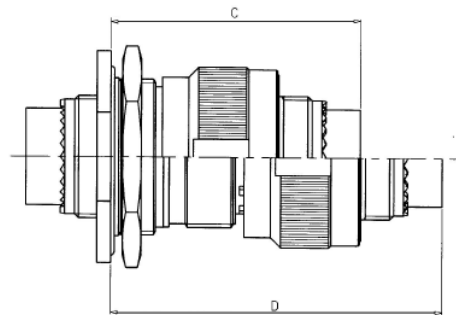

Jam nut receptacle type 7 with plug

Shell size	A Max.	B Max.	C Max.	D Max.
09	43.50	58.80	44.80	60.10
11	43.50	58.80	44.80	60.10
13	43.50	58.80	45.00	60.30
19	43.50	58.80	45.00	60.30
25	43.50	58.80	45.00	60.30

Dimensions in millimeters

8D - JVS Series with optical Elio contacts



Dimensions of ELIO™ Termini - Straight long boot version (L)

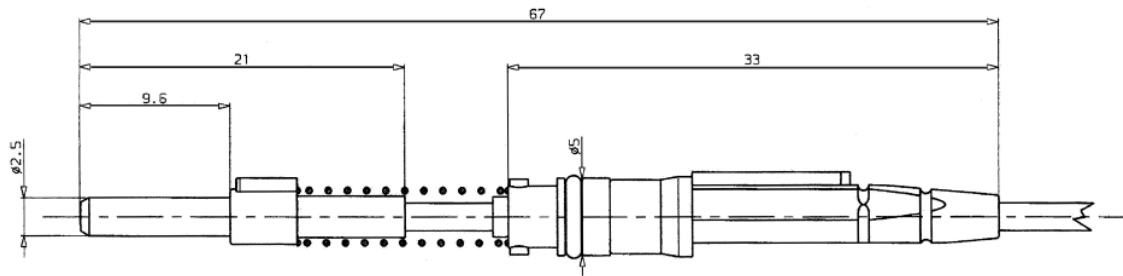

Rear dimensions of the straight long boot version of the ELIO™ Termini

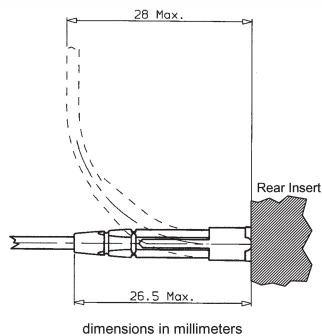

Rear dimensions of the straight short boot version of the ELIO™ Termini

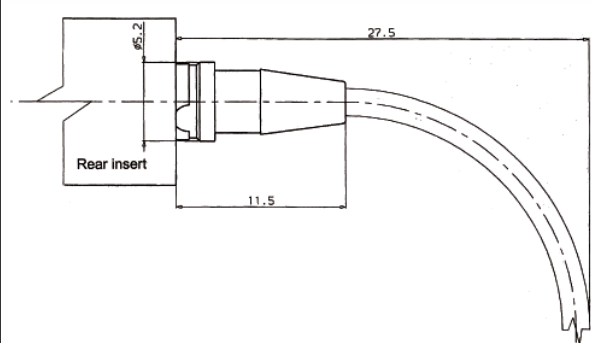

Rear dimensions of the ELIO™ Termini without boot

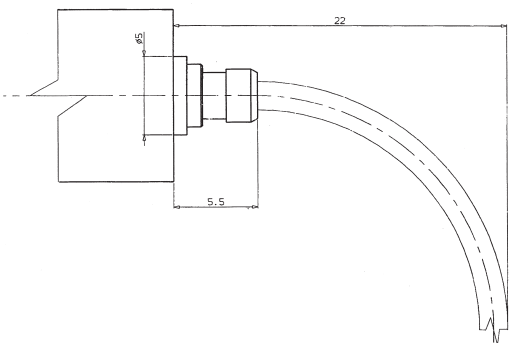

Dimensions in millimeters

Ordering information

ELIO™	18 S	G	L
Cable diameter wider:			
SBN for 980 µm jacket cable or cable wider than 2 mm with 900 µm fiber - without sealing joint			
SCN from 1.5 mm up to 1.9 mm cable - without sealing joint			
18S for 1.8 mm cable			
Fiber type:			
G for 50/125 or 62.5/125 fiber (PC shape ferrule)			
D for 100/140 fiber			
J for POF 1.0 mm fiber - with sealing joint			
Boot shape:			
L Straight long			
S Straight short			
N Without boot (unsealed version only)			

8D - JVS Series with optical Elio contacts



Adaptor for standard backshells

Elio - ABA

Shell size:

09 - 11 - 13 - 25

Plating:

W: Olive drab cadmium

F: Nickel

Note : Backshells adaptor is placed between connector and standard backshell.

Shell size	Ø A Maxi	B Thread
09	20	M12 x 1-6g
11	20	M15 x 1-6g
13	23	M18 x 1-6g
25	48	M37 x 1-6g

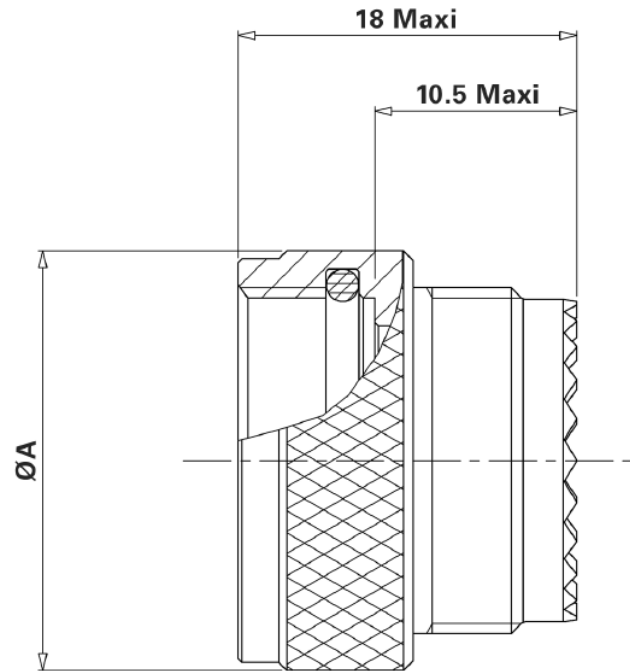

Tooling data

Insertion and extraction tool

For the terminus with boot



P/N : ELI1-0231A

For the terminus without boot

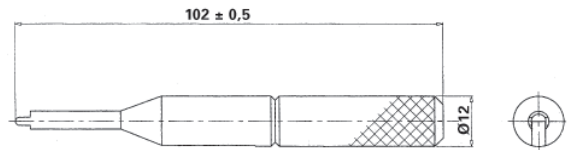

P/N : 80WV0049A

8D reinforced sealing series

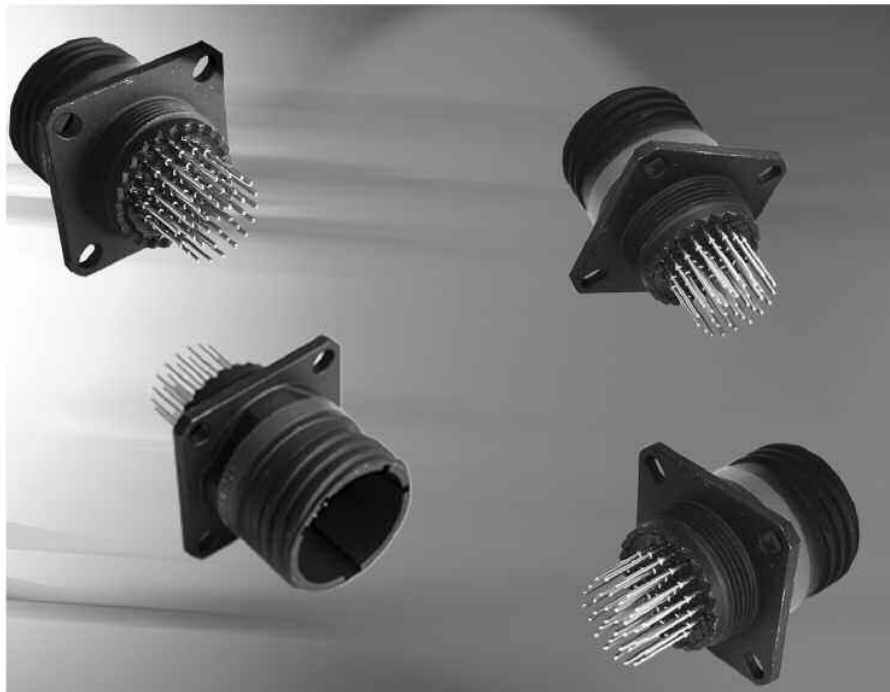

Derived from:
MIL-DTL-38999 Serie III

8D reinforced sealing series



Description

- Reinforced sealing receptacle with male or female straight spill contacts.
- High hermeticity performance: 10^{-7} atm.cm³/s
- 100 % scoop proof.
- High density connectors.
- Lower profile for compactness.
- Weight saving compared to hermetic version.
- Reinforced sealing for harsh environments.
- Good shock resistance.

Layouts

Arrangements / Layouts

All 8D layouts can be manufactured with Resin sealed (except power).

Ordering information

After the basic series "8D", related to the digit "R" (8D+R...).

Don't forget the digit related to the spill length (C, M, L, S).

Examples:

8D (Alu) = 8DR 0 C 13 W 35 PN

8D (Titane) = 8DR 7 L 13 TT 35 PN

Comparison between standard, reinforced sealing and hermetic version

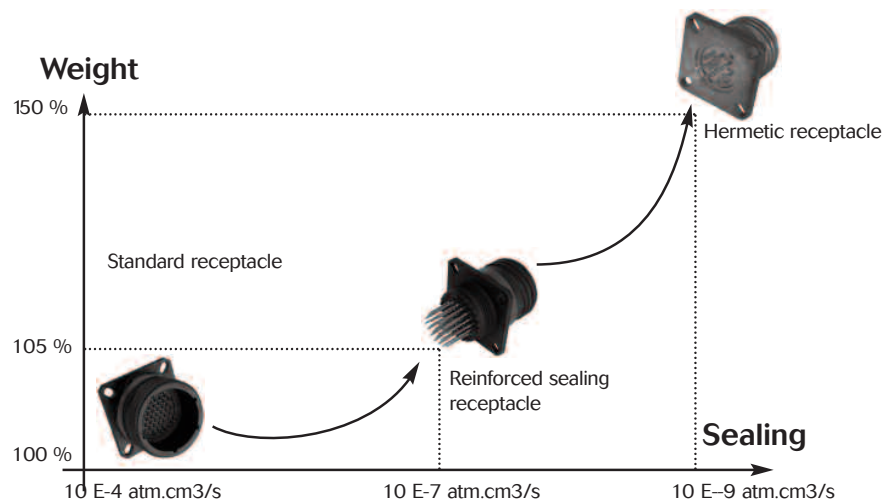

F 38999 Hermetic

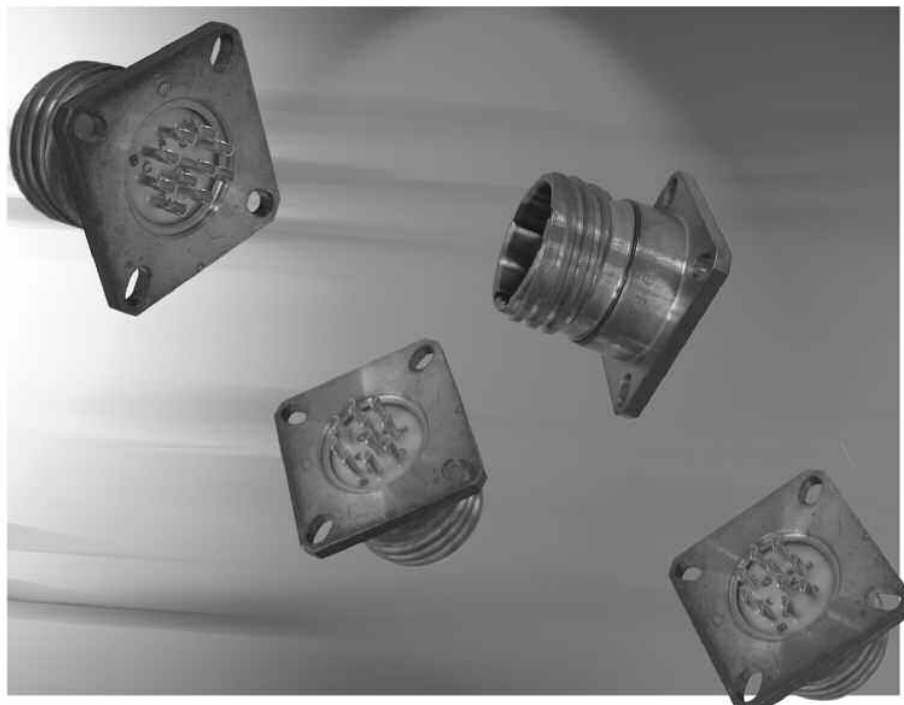

Derived from:
MIL-DTL-38999 Serie III

F 38999 Hermetic

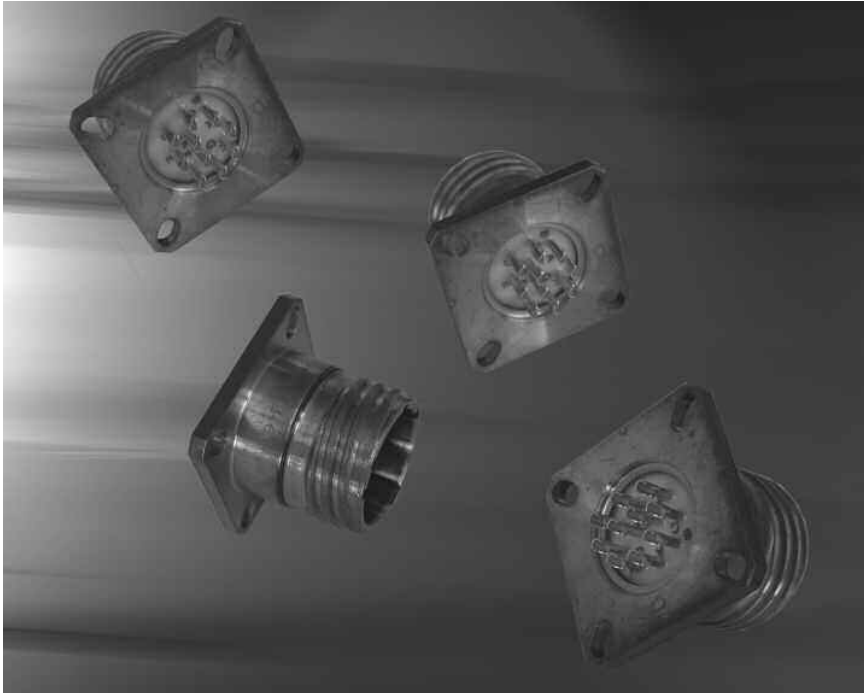

Description

As per MIL-DTL 38999

- Glass insulator
- High hermeticity performance
- Ideal for high pressure environments
- Low profile

Technical features

Mechanical

- **Shell:** stainless steel
- **Shell plating:** passivated
- **Interfacial seal:** silicone elastomer
- **Contacts:** gold
- **Endurance:** 500 operations
- **Hermeticity:**
no leakage in excess of 10^{-7} cm³/s

Electrical

- **Test voltage rating:**

Service	Sea level	At 2100 m
M	1 300	800
I	1 800	1 000

- **Shielding:** 45 dB at 10 GHz

- **Insulation resistance:**
5000 mΩ (under 500 Vdc)

- **Current rating:**

Contact size	Rating (A)
# 22 D	3
# 20	5
# 16	10
# 12	17

Environmental

- **Temperature:** -65°C at 200°C
- **Salt spray:** per MIL DTL 38999

F 38999 Hermetic



Ordering information

Basic Series	F38999	21	Y	A	35	P	N	WF	-
Shell style:									
21: Box mounting flange receptacle									
23: Jam nut receptacle									
25: Solder mounting receptacle									
Class:									
Y: Passivated stainless steel									
Shell size:									
A: 09 B: 11 C: 13 D: 15 E: 17 F: 19 G: 21 H: 23 J: 25									
Layout:									
See page 11									
Contact types:									
P: Male solder cup									
C: Male straight spill (please consult us)									
Orientation:									
N, A, B, C, D, E (See page 58)									
WF: Mandatory suffix									
Specification:									
None for standard product									

Box mounting flange receptacle (type 21)

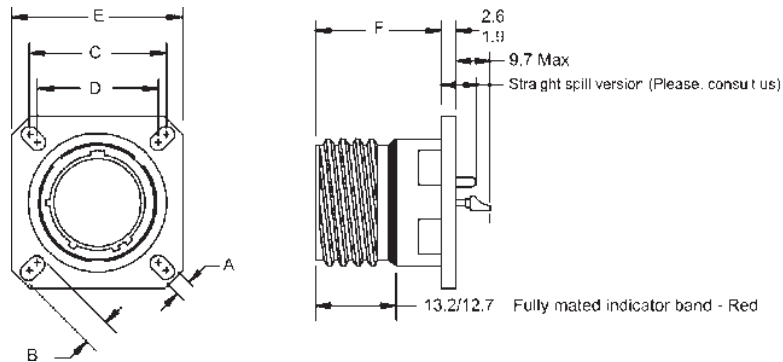

Shell size	A ± 0.20	B ± 0.20	C	D	E ± 0.30	F Max.
A (9)	3.25	5.49	18.26	15.09	23.80	21.40
B (11)	3.25	4.93	20.62	18.26	26.20	21.40
C (13)	3.25	4.93	23.01	20.62	28.60	21.40
D (15)	3.25	4.93	24.61	23.01	31.00	21.40
E (17)	3.25	4.93	26.97	24.61	33.30	21.40
F (19)	3.25	4.93	29.36	26.97	36.50	21.40
G (21)	3.25	4.93	31.75	29.36	39.70	21.40
H (23)	3.91	6.15	34.93	31.75	42.90	21.40
J (25)	3.91	6.15	38.10	34.93	46.00	21.40

Dimensions in millimeters

F 38999 Hermetic



Jam nut receptacle type 23

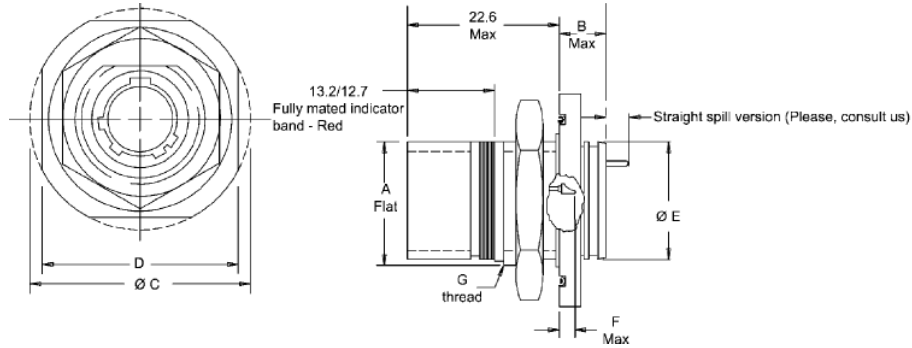

Shell size	A flat $+ .10$ $- .15$	B Max.	$\text{Ø C} \pm .3$	$\text{Ø D} \pm .4$	$\text{Ø E} \pm .3/0$	F Max.	G thread
A (9)	16.53	9.10	30.20	27.00	16.30	5.30	M17 x 1-6g
B (11)	19.07	9.10	34.90	31.80	19.40	5.30	M20 x 1-6g
C (13)	23.82	9.10	38.10	34.90	22.70	5.10	M25 x 1-6g
D (15)	26.97	9.10	41.30	38.10	25.90	5.10	M28 x 1-6g
E (17)	30.15	9.10	44.50	41.30	29.00	5.10	M32 x 1-6g
F (19)	33.32	9.70	49.20	46.00	32.20	5.10	M35 x 1-6g
G (21)	36.50	9.70	52.40	49.20	35.40	5.10	M38 x 1-6g
H (23)	39.67	9.70	55.60	52.40	38.60	5.10	M41 x 1-6g
J (25)	42.85	9.70	58.70	55.60	41.70	5.10	M44 x 1-6g

Solder mounting receptacle (type 25)

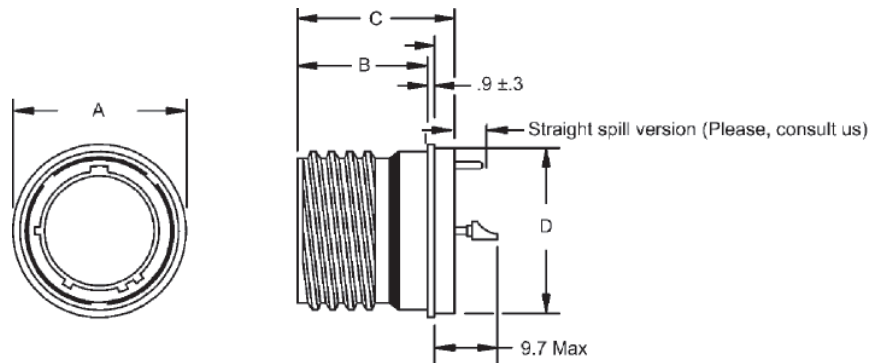

Shell size	Ø A Max.	B Max.	C Max.	D Max.
A (9)	19.40	17.20	23.80	17.10
B (11)	21.80	17.20	23.80	19.90
C (13)	24.90	17.20	23.80	23.10
D (15)	28.10	17.20	23.80	26.20
E (17)	31.30	17.20	23.80	29.40
F (19)	33.60	17.20	23.80	31.80
G (21)	36.80	17.20	23.80	35.00
H (23)	40.00	17.20	24.60	38.20
J (25)	43.20	17.20	24.60	41.30

Dimensions in millimeters

8D Series with RJ45 USB



Derived from:
MIL-DTL-38999 Serie III

8D Series with RJ45 USB



Description

- Derived from MIL-DTL-38999 Serie III
- True ruggedized RJ45 & USB A solution
- High vibration resistance
- Shock resistant
- IP67
- Shielded
- No tools for cabling

Application

- Data transmission using standard interface.
- Flight data transmissions.

Technical features

Mechanical

- **Aluminium:**
- **Composite:**
- **Shell:** aluminium alloy or carbon reinforced thermoplastic
- **Shell plating:**
 - nickel or olive green cadmium
 - composite no protection
- **Insert:** thermoplastic
- **Endurance:** 500 matings
- **Vibration:** 10-500 Hz 20 g

- **RJ 45 receptacle jack:**
- **USB A jack receptacle:**

Electrical

- **RJ45:** - 10 BaseT, 100 BaseTX and 1000 BaseT Networks cat 5^e per TIA/EIA 568 A/B
- **USB serie A:** meet all requirement of the "Universal serial bus specification" (revision 2)

Environmental

- **Meets MIL-DTL-38999 Excepted:**
- **Sealing:** IP67 with cap MIL-DTL-38999
- **Temperature:** -40°C at 85°C

Fluid resistance

- **Meets MIL-DTL-38999 Excepted:**
 - with a cap**
 - Backshells and caps
 - Per AS85049 or equivalent sold separately

NB: No tools for cabling

8D Series with RJ45 USB



Ordering information

Basic Series	8D	0	F	19	W	RJ	S	N	***
<p>Shell style: 0: square flange receptacle 5: plug 7: jam nut receptacle (Aluminium only)</p>									
<p>Designator: F: feedthrough S: solder out C: Pigtail cable receptacle P: Pigtail cable plug</p>									
<p>Shell size: 17: USB 19: RJ 45</p>									
<p>Plating: W: cadmium / olive drab cadmium (Aluminium) F: nickel (Aluminium) X: no plating (composite) J: cadmium / olive drab cadmium (composite) M: nickel / nickel (composite) L: black zinc (Aluminium) - Please, consult us</p>									
<p>Insert: RJ: RJ 45 UA: USB type A</p>									
<p>Contact style: S: receptacle P: plug</p>									
<p>Keying: N, A, B, C, D, E (See page 58)</p>									
<p>Cable length: inches required for type C Please, consult us for cable lengths & end connectors</p>									

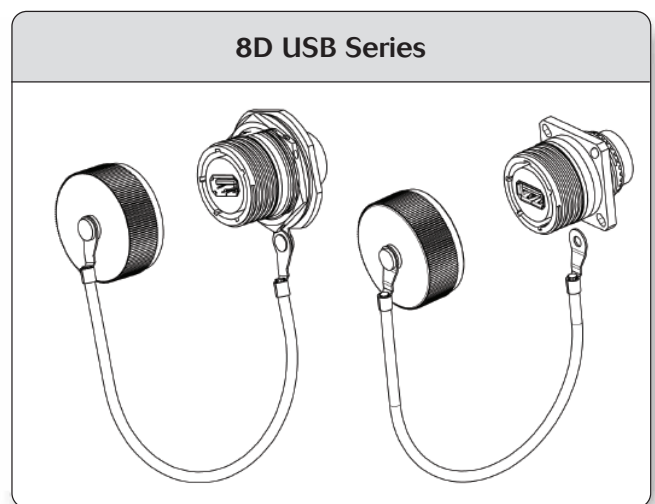
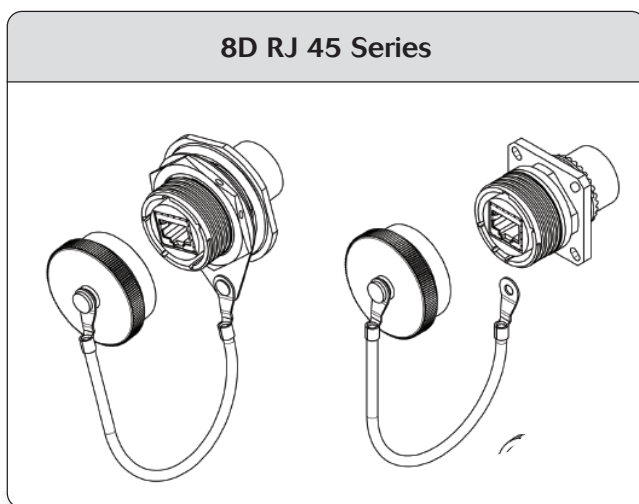

8D Series with RJ45 USB



RJ 45 Feedthrough serie

Jam nut receptacle

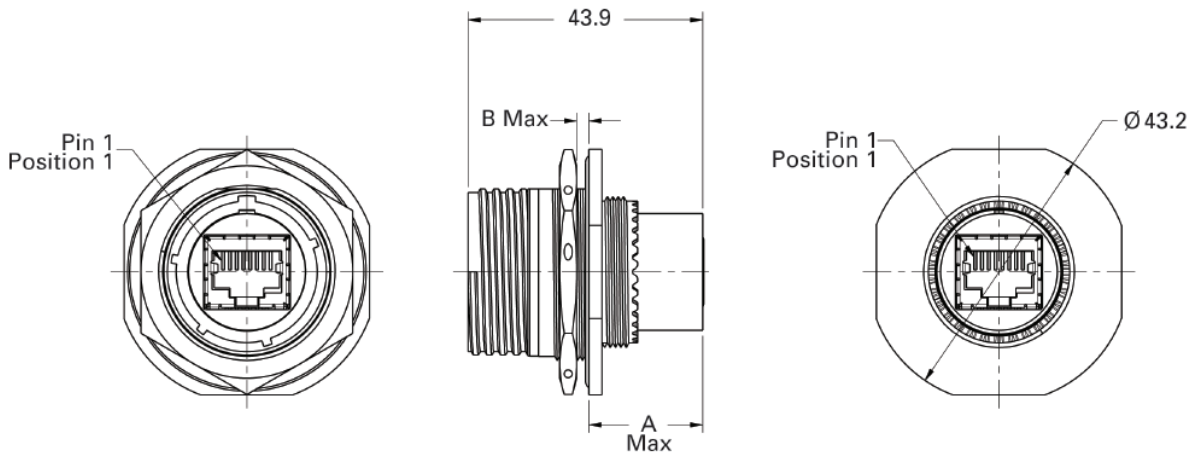

Shell type	A Max.	B Max.
Aluminium	21.34	3.20

Square flange receptacle

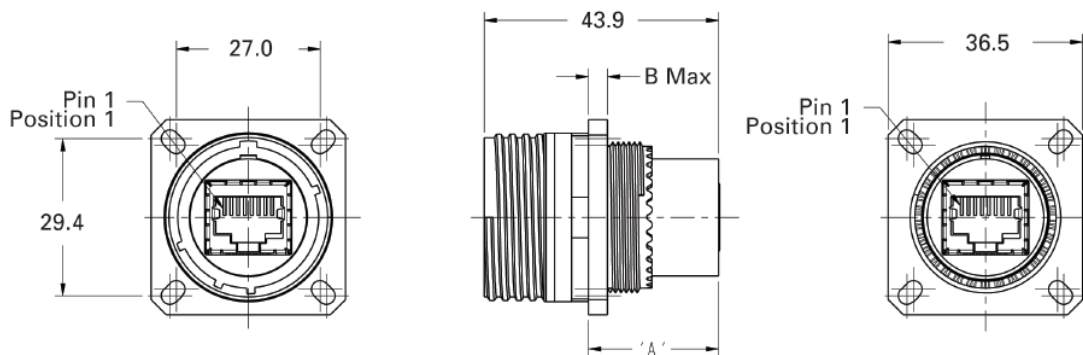

Shell type	A Max.	B Max.
Aluminium	21.34	3.20
Composite	21.34	3.20

8D Series with RJ45 USB



RJ45 Solder out serie

Suare flange receptacle

Shell type	A Max.	B Max.
Aluminium	11.91	2.50
Composite	12.14	3.65

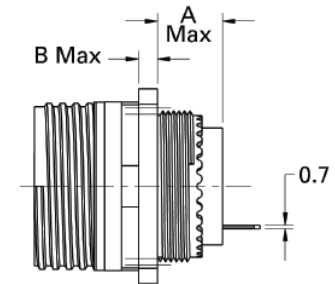
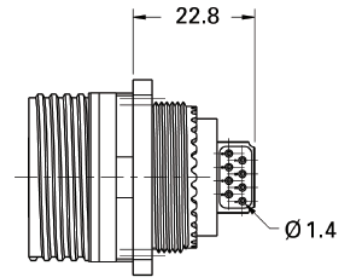
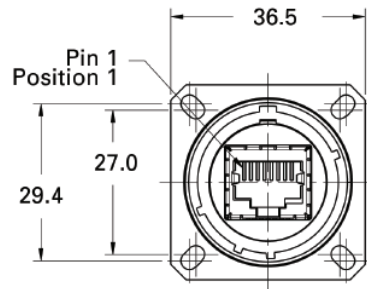

Jam nut receptacle

Shell type	A Max.	B Max.
Aluminium	12.70	3.20

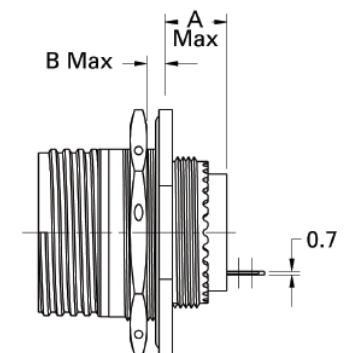
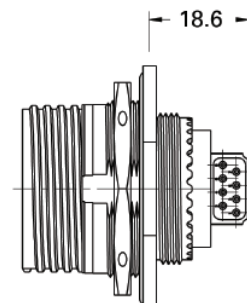
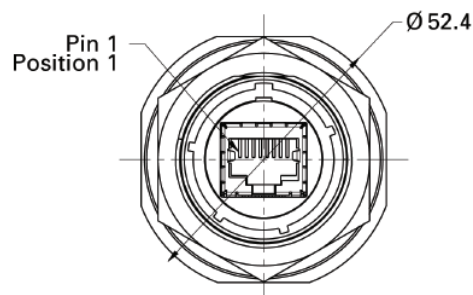

8D Series with RJ45 USB



RJ45 Pigtail serie

Suare flange receptacle

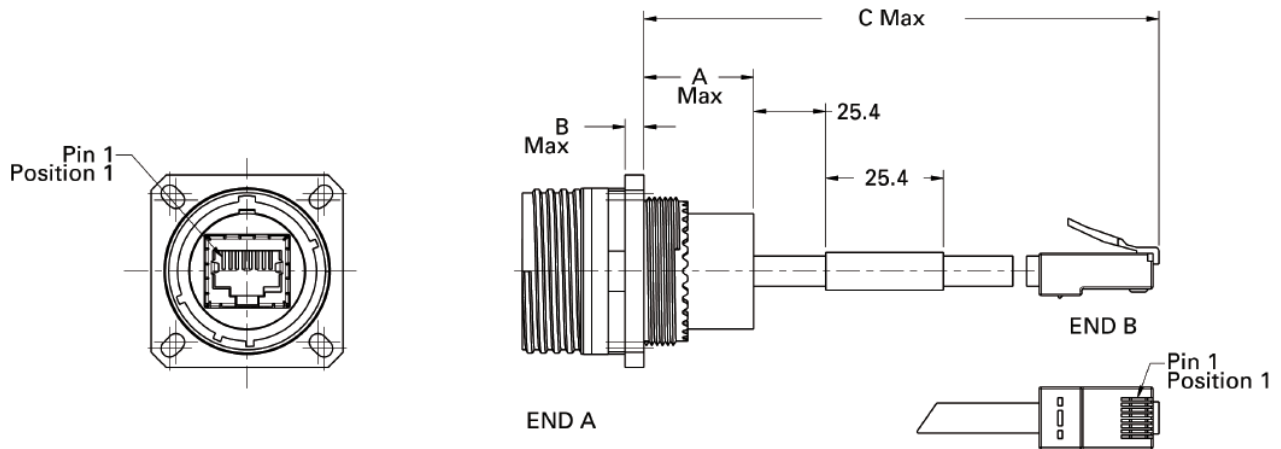

Shell type	A Max.	B Max.	C Max.
Aluminium	20.78	2.50	304.80 ±25.4
Composite	20.78	3.65	304.80 ±25.4

Jam nut receptacle

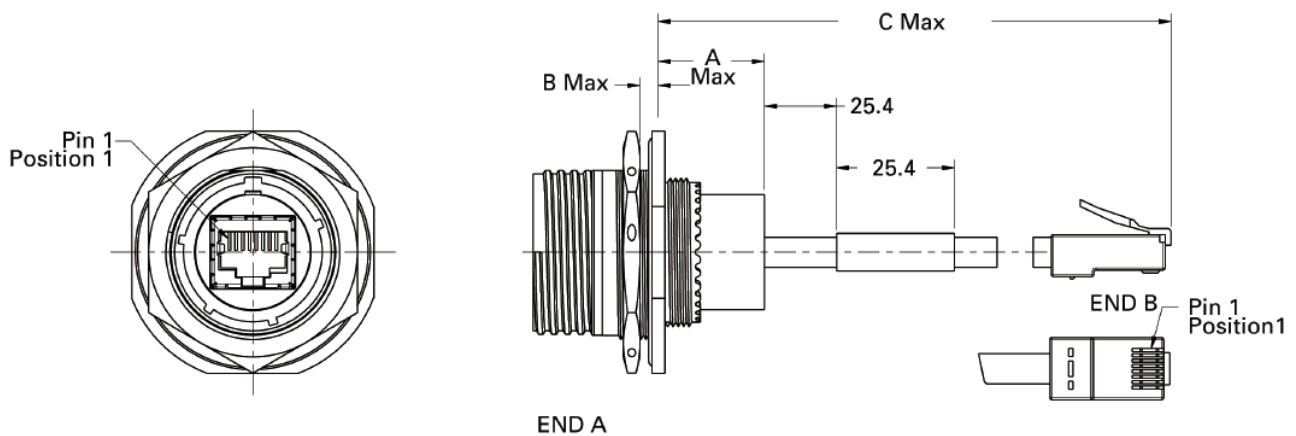

Shell type	A Max.	B Max.	C Max.
Aluminium	21.34	3.20	304.80 ±25.4

8D Series with RJ45 USB



Panel cut out for RJ45 serie

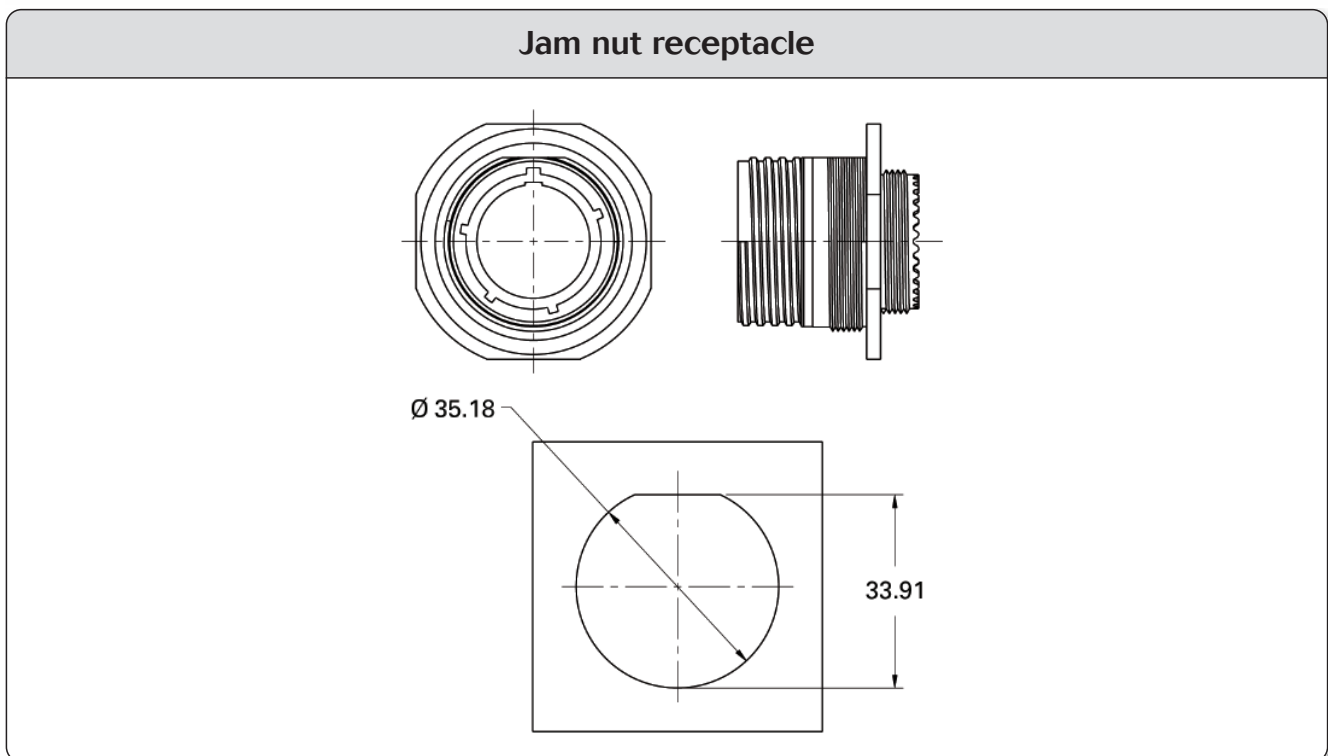
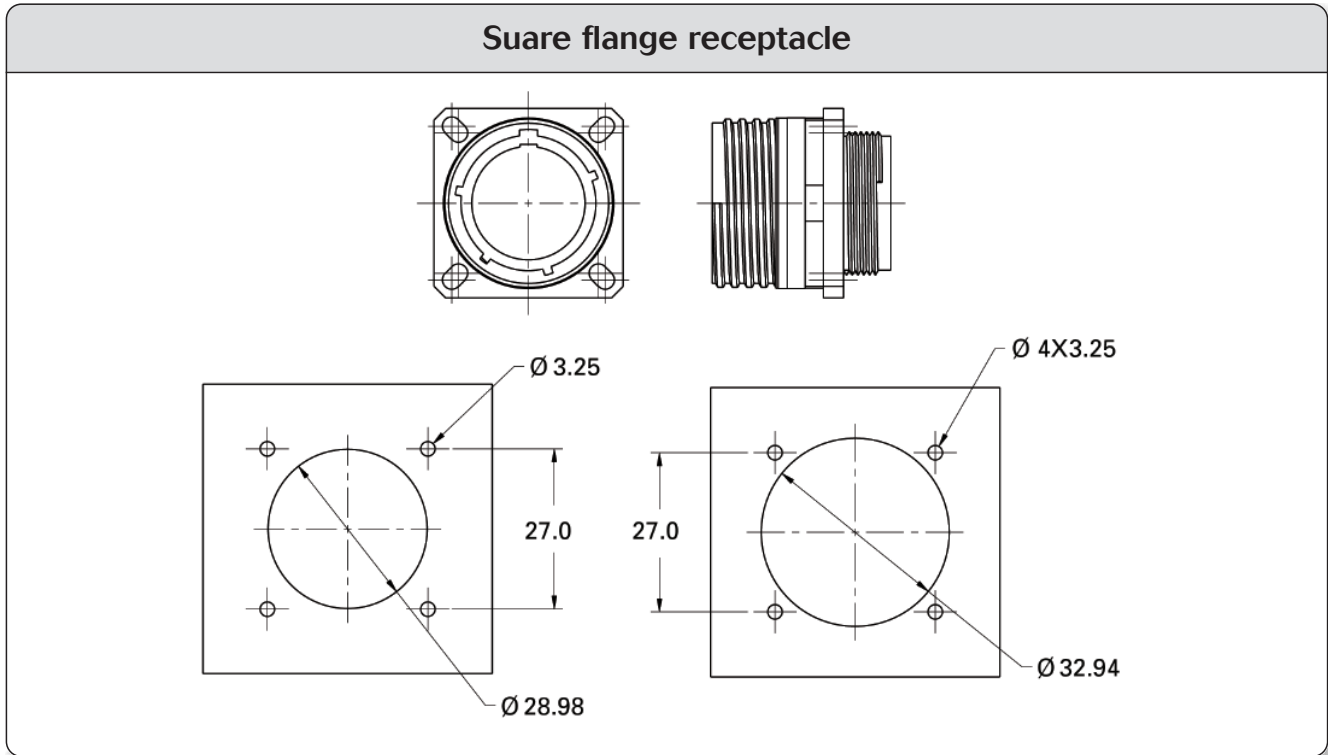

8D Series with RJ45 USB



USB Feedthrough serie

Jam nut receptacle

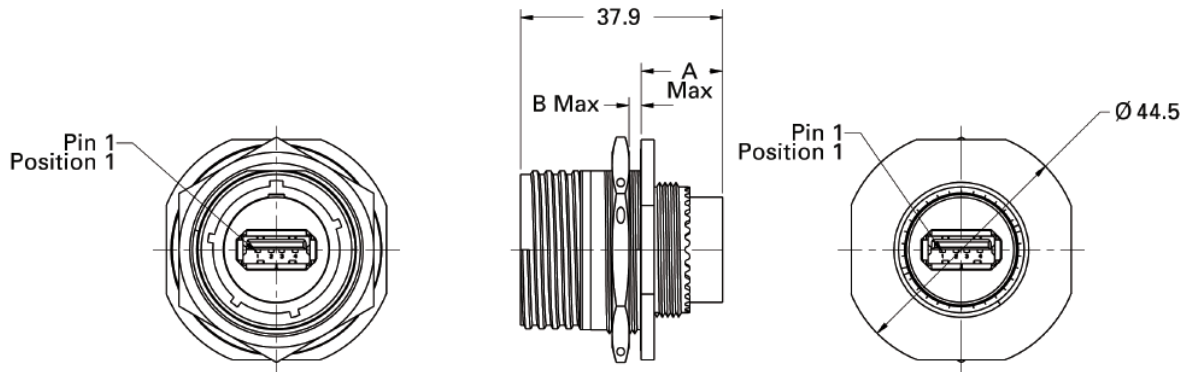

Shell type	A Max.	B Max.
Aluminium	15.24	3.20

Square flange receptacle

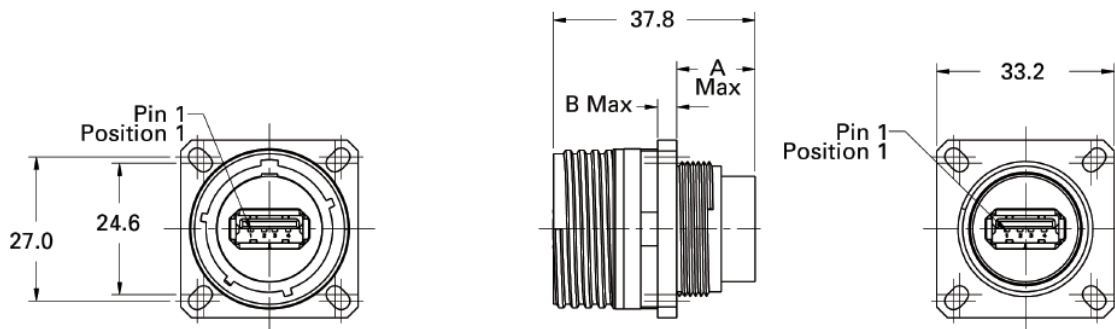

Shell type	A Max.	B Max.
Aluminium	4.45	2.50
Composite	4.88	3.85

8D Series with RJ45 USB



USB Solder out serie

Suare flange receptacle

Shell type	A Max.	B Max.
Aluminium	8.10	2.50
Composite	8.33	3.65

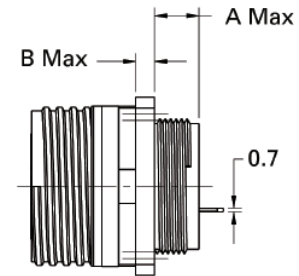
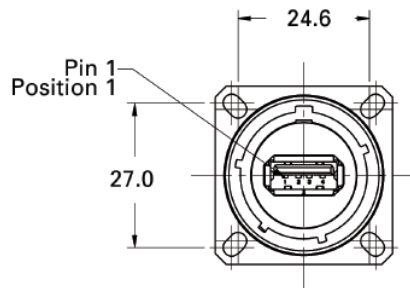
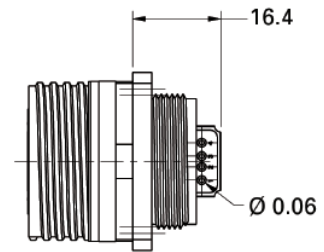

Jam nut receptacle

Shell type	A Max.	B Max.
Aluminium	11.94	3.20

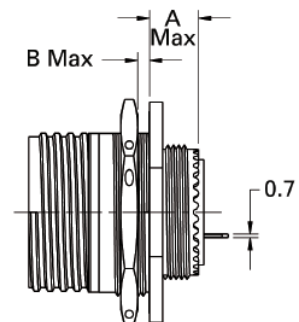
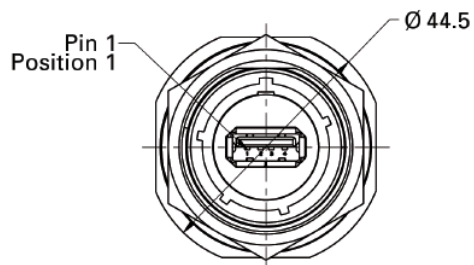
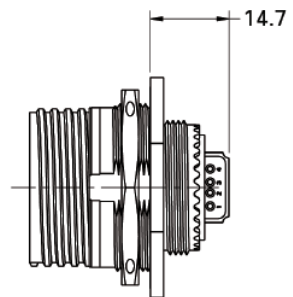

8D Series with RJ45 USB



USB Pigtail serie

Suare flange receptacle

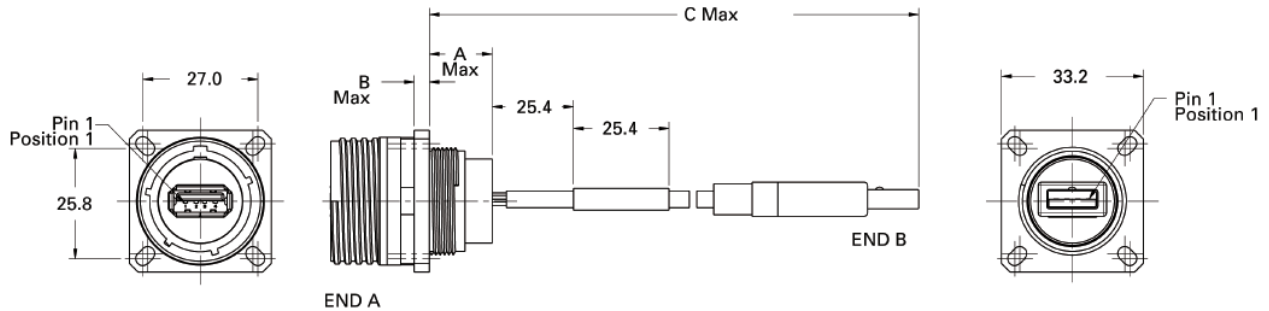

Shell type	A Max.	B Max.	C Max.
Aluminium	14.45	2.50	304.80 ±25.4
Composite	14.68	3.65	304.80 ±25.4

Jam nut receptacle

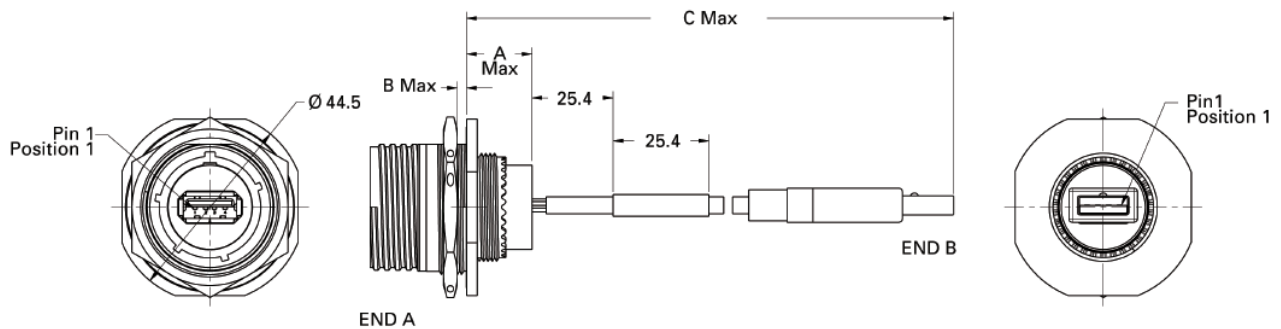

Shell type	A Max.	B Max.	C Max.
Aluminium	15.24	3.20	304.80 ±25.4

8D Series with RJ45 USB



Panel cut out for USB series

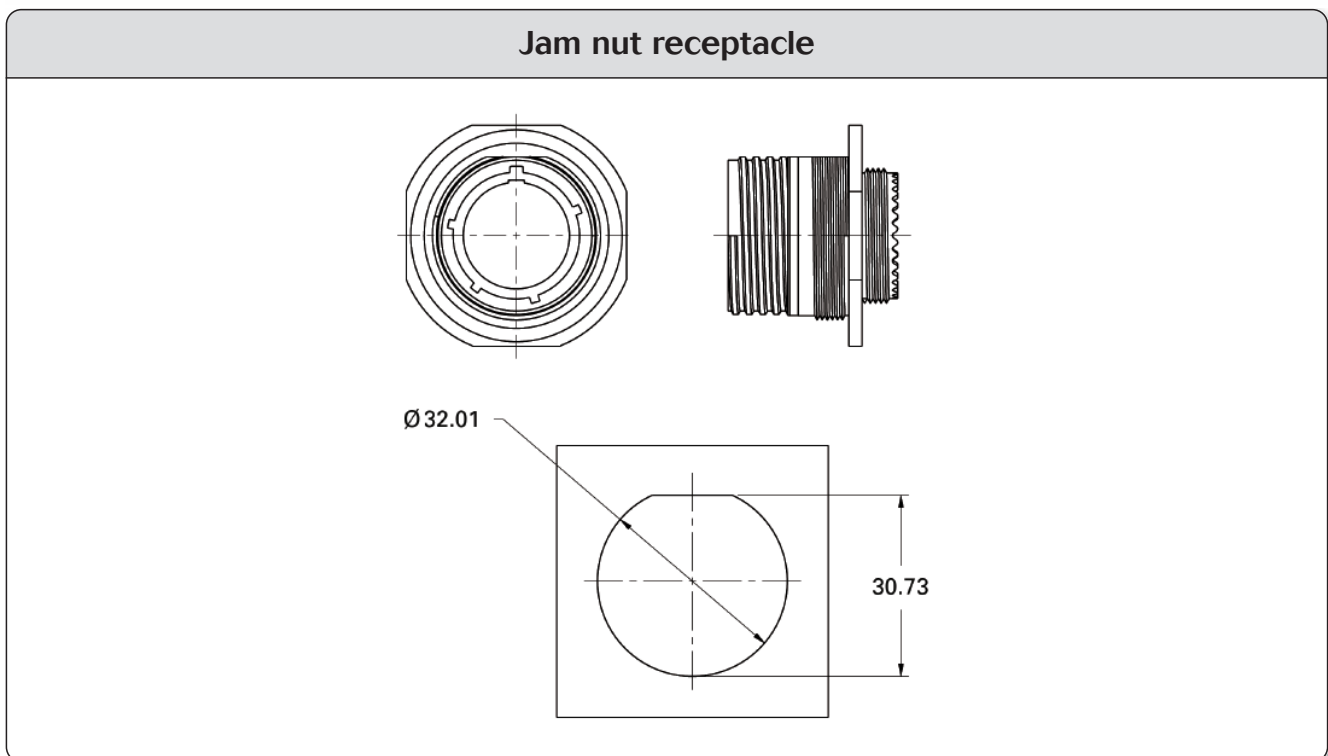
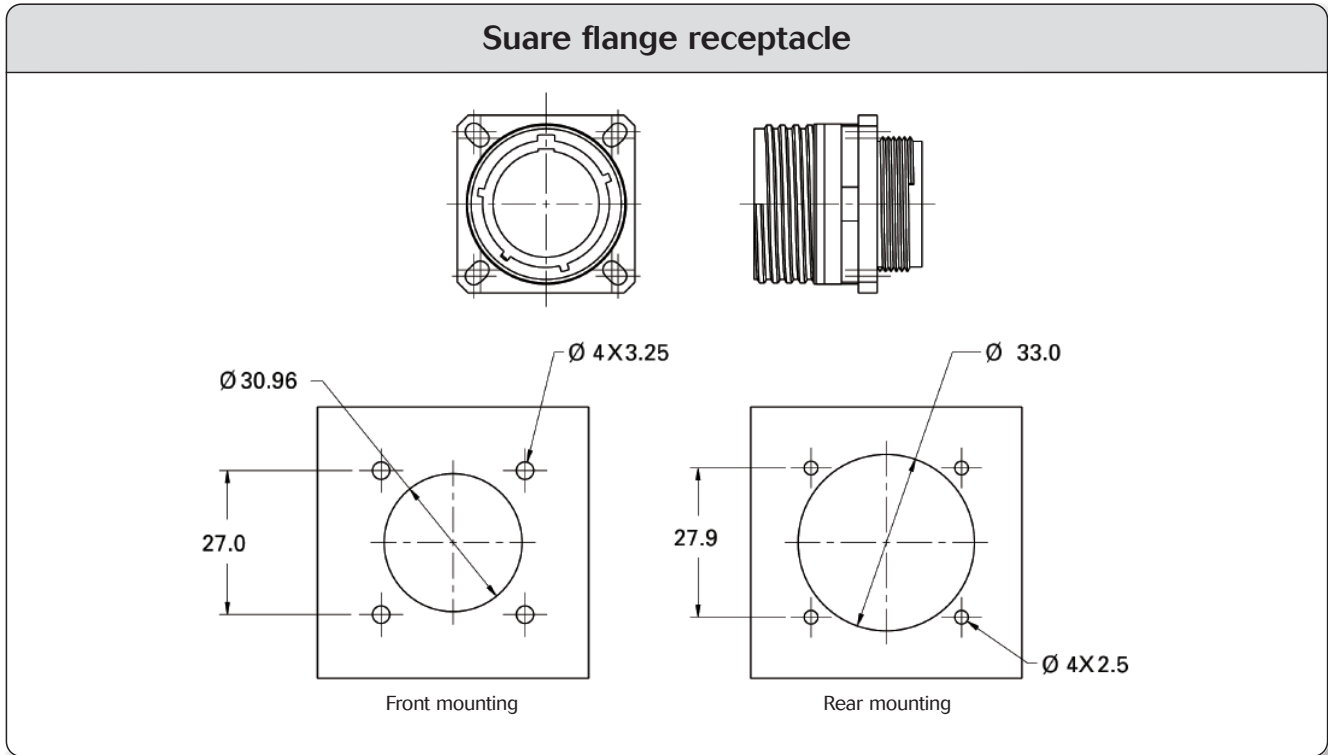

Coordinates for straight spill terminations



Cavity identification – Viewed from front face of male insulator

Hole sizes: 1 mm min. (#22 and 20 contacts) and 1,3 mm min. (# 16 contact) coordinates in mm.

9

35

98

Contact	Coordinates	
	X	Y
1	+1.14	+1.98
2	+1.98	-1.14
3	0.00	-2.29
4	-1.98	-1.14
5	-1.14	+1.98
6	0.00	0.00

Contact	Coordinates	
	X	Y
1	+1.65	+0.97
2	0.00	-1.90
3	-1.65	+0.97

11

02

35

98

99

Contact	Coordinates	
	X	Y
1	0.00	+2.41
2	0.00	-2.41

Contact	Coordinates	
	X	Y
1	0.00	+3.71
2	+2.16	+3.00
3	+3.50	+1.14
4	+3.50	-1.14
5	+2.16	-2.99
6	0.00	-3.71
7	-2.16	-2.99

Contact	Coordinates	
	X	Y
8	-3.50	-1.14
9	-3.50	+1.14
10	-2.16	+2.99
11	0.00	+1.42
12	+1.24	-0.89
13	-1.24	-0.89

Contact	Coordinates	
	X	Y
A	0.00	+3.30
B	+3.30	0.00
C	+1.65	-2.87
D	-1.65	-2.87
E	-3.30	0.00
F	0.00	0.00

Contact	Coordinates	
	X	Y
A	+1.65	+2.85
B	+3.30	0.00
C	+1.65	-2.87
D	-1.65	-2.87
E	-3.30	0.00
F	-1.65	+2.87
G	0.00	0.00

05

04

Contact	Coordinates	
	X	Y
A	+1.65	+1.42
B	+2.86	-1.65
C	0.00	-3.30
D	-2.86	-1.65
E	-1.65	+1.42

Contact	Coordinates	
	X	Y
A	+1.65	+1.65
B	+1.65	-1.65
C	-1.65	-1.65
D	-1.65	+1.65

Coordinates for straight spill terminations



13

04

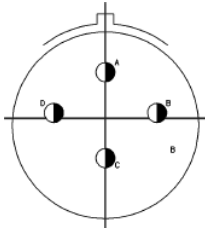

Contact	Coordinates	
	X	Y
A	0.00	+3.81
B	+3.71	+0.89
C	0.00	-2.11
D	-3.71	-0.89

35

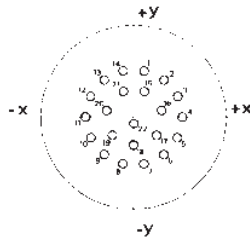

Contact	Coordinates	
	X	Y
1	+1.14	+5.00
2	+3.20	+4.01
3	+4.62	+2.24
4	+5.15	0.00
5	+4.62	-2.24
6	+3.20	-4.01
7	+1.14	-5.00
8	-1.14	-5.00
9	-3.20	-4.01
10	-4.62	-2.24
11	-5.15	0.00

98

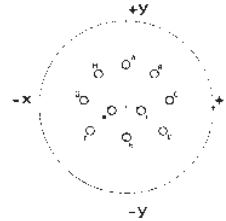

Contact	Coordinates	
	X	Y
A	0.00	+4.95
B	+3.81	+3.80
C	+4.90	+0.76
D	+4.16	-2.67
E	0.00	-3.43
F	-4.16	-2.67
G	-4.90	+0.76
H	-3.81	+3.80
J	+1.65	-0.38
K	-1.65	-0.38

08

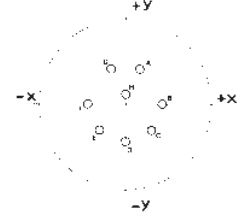

Contact	Coordinates	
	X	Y
A	+1.65	+3.99
B	+4.32	0.00
C	+3.05	-3.05
D	0.00	-4.32
E	-3.05	-3.05
F	-4.32	0.00
G	-1.65	+3.99
H	0.00	+1.12

15

35

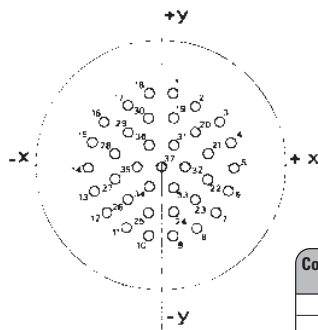

Contact	Coordinates	
	X	Y
1	+1.14	+6.65
2	+3.12	+5.51
3	+5.36	+4.06
4	+6.45	+2.03
5	+6.76	-0.25
6	+6.27	-2.49
7	+5.08	-4.44
8	+3.30	-5.89
9	+1.14	-6.65
10	-1.14	-6.65
11	-3.30	-5.89
12	-5.08	-4.45
13	-6.27	-2.49
14	-6.76	-0.25
15	-6.45	+2.03
16	-5.36	+4.06

Contact	Coordinates	
	X	Y
17	-3.12	+5.51
18	-1.14	+6.65
19	+1.14	+4.37
20	+3.12	+3.02
21	+4.32	+1.02
22	+4.32	-1.27
23	+3.12	-3.23
24	+1.14	-4.37
25	-1.14	-4.37
26	-3.12	-3.23
27	-4.32	-1.27
28	-4.32	+1.02
29	-3.12	+3.02
30	-1.14	+4.37
31	+1.14	+1.88
32	+2.29	-0.10
33	+1.14	-2.08
34	-1.14	-2.08
35	-2.29	-0.10
36	-1.14	+1.88
37	0.00	-0.10

19

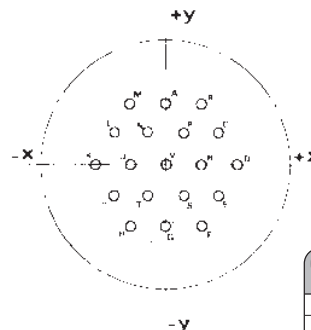

Contact	Coordinates	
	X	Y
A	0.00	+5.72
B	+3.30	+5.72
C	+4.95	+2.72
D	+6.60	0.00
E	+4.95	-2.87
F	+3.30	-5.72
G	0.00	-5.72
H	-3.30	-5.72
J	-4.95	-2.87
K	-6.60	0.00
L	-4.95	+2.87
M	-3.30	+5.72
N	-1.65	+2.87
P	+1.65	+2.87
R	+3.30	0.00
S	+1.65	-2.87
T	-1.65	-2.87
U	-3.30	0.00
V	0.00	0.00

Coordinates for straight spill terminations



15

18

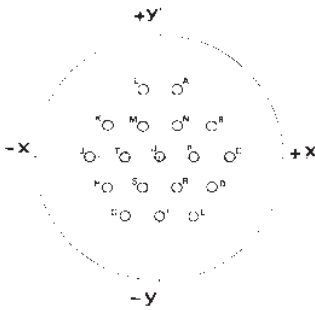

Contact	Coordinates		Contact	Coordinates	
	X	Y		X	Y
A	+1.65	+6.40	K	-4.95	+2.87
B	+4.95	+2.87	L	-1.65	+6.40
C	+6.60	0.00	M	-1.65	+2.87
D	+4.95	-2.87	N	+1.65	+2.87
E	+3.30	-5.72	P	+3.30	0.00
F	0.00	-5.72	R	+1.65	-2.87
G	-3.30	-5.72	S	-1.65	-2.87
H	-4.95	-2.87	T	-3.30	0.00
J	-6.60	0.00	U	0.00	0.00

05

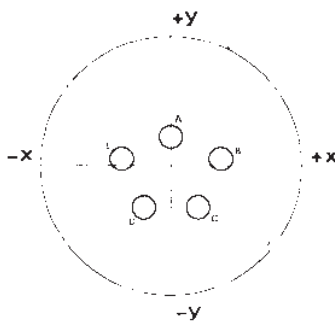

Contact	Coordinates	
	X	Y
A	0	+2.54
B	+4.42	+0.61
C	+2.39	+3.76
D	-2.39	-3.76
E	-4.42	+0.61

97

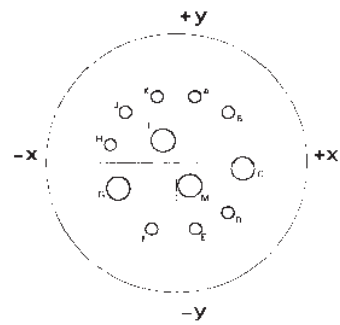

Contact	Coordinates		Contact	Coordinates	
	X	Y		X	Y
A	+1.65	+5.94	G	-5.26	-2.41
B	+4.52	+4.52	H	-5.94	+1.65
C	+5.84	-0.58	J	-4.52	+4.52
D	+4.52	-4.52	K	-1.65	+5.94
E	+1.65	-5.94	L	-1.19	+2.06
F	-2.26	-5.97	M	+1.19	-2.06

17

35

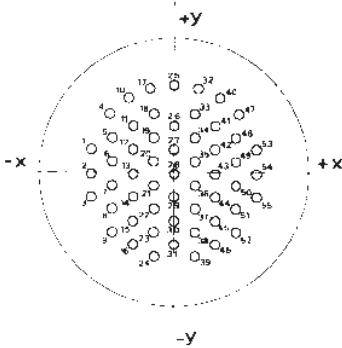

Contact	Coordinates		Contact	Coordinates	
	X	Y		X	Y
1	-7.92	+2.18	14	-3.96	-2.39
2	-7.92	-0.10	15	-3.96	-4.67
3	-7.92	-2.39	16	-3.96	-6.96
4	-6.15	+5.61	17	-2.26	+8.03
5	-5.94	+3.33	18	-1.98	+5.61
6	-5.94	+1.04	19	-1.98	+3.33
7	-5.94	+1.24	20	-1.98	+1.04
8	-5.94	-3.53	21	-1.98	-1.24
9	-5.94	-5.82	22	-1.98	-3.53
10	-4.37	+7.09	23	-1.98	-5.82
11	-3.96	+4.47	24	-1.98	+8.10
12	-3.96	+2.18	25	0.00	+8.36
13	-3.96	-0.10	26	0.00	+4.47

Contact	Coordinates	
	X	Y
27	0.00	+2.18
28	0.00	-0.10
29	0.00	-2.39
30	0.00	-4.67
31	0.00	-6.96
32	+2.26	+8.03
33	+1.98	+5.61
34	+1.98	+3.33
35	+1.98	+1.04
36	+1.98	-1.24
37	+1.98	-3.53
38	+1.98	-5.82
39	+1.98	-8.10
40	+4.37	+7.09
41	+3.96	+4.47
42	+3.96	+2.18
43	+3.96	-0.10
44	+3.96	-2.39
45	+3.96	-4.67
46	+3.96	-6.96
47	-6.15	+5.61
48	+5.94	+3.33
49	+5.94	+1.04
50	+5.94	-1.24
51	+5.94	-3.53
52	+5.94	-5.82
53	+7.92	+2.18
54	+7.92	-0.10
55	+7.92	-2.39

26

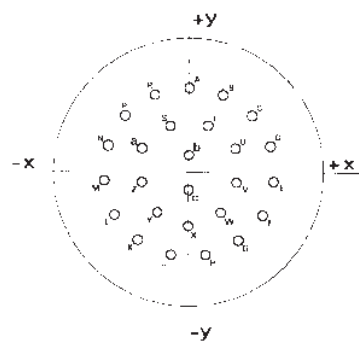

Contact	Coordinates		Contact	Coordinates	
	X	Y		X	Y
A	0.00	+8.15	P	-6.07	+5.44
B	+3.33	+7.44	R	-3.33	+7.44
C	+6.07	+5.44	S	-1.78	+4.50
D	+7.75	+2.51	T	+1.78	+4.50
E	+8.10	-0.86	U	+4.45	+2.39
F	+7.06	-4.09	V	+4.53	+0.91
G	+4.80	-6.60	W	+3.02	-3.84
H	+1.70	-7.98	X	0.00	-5.16
J	-1.70	-7.98	Y	-3.02	-3.84
K	-4.80	-6.60	Z	-4.53	-0.91
L	-7.06	-4.09	a	-4.45	+2.39
M	-8.10	-0.86	b	0.00	+1.65
N	-7.75	+2.51	c	0.00	-1.65

Coordinates for straight spill terminations

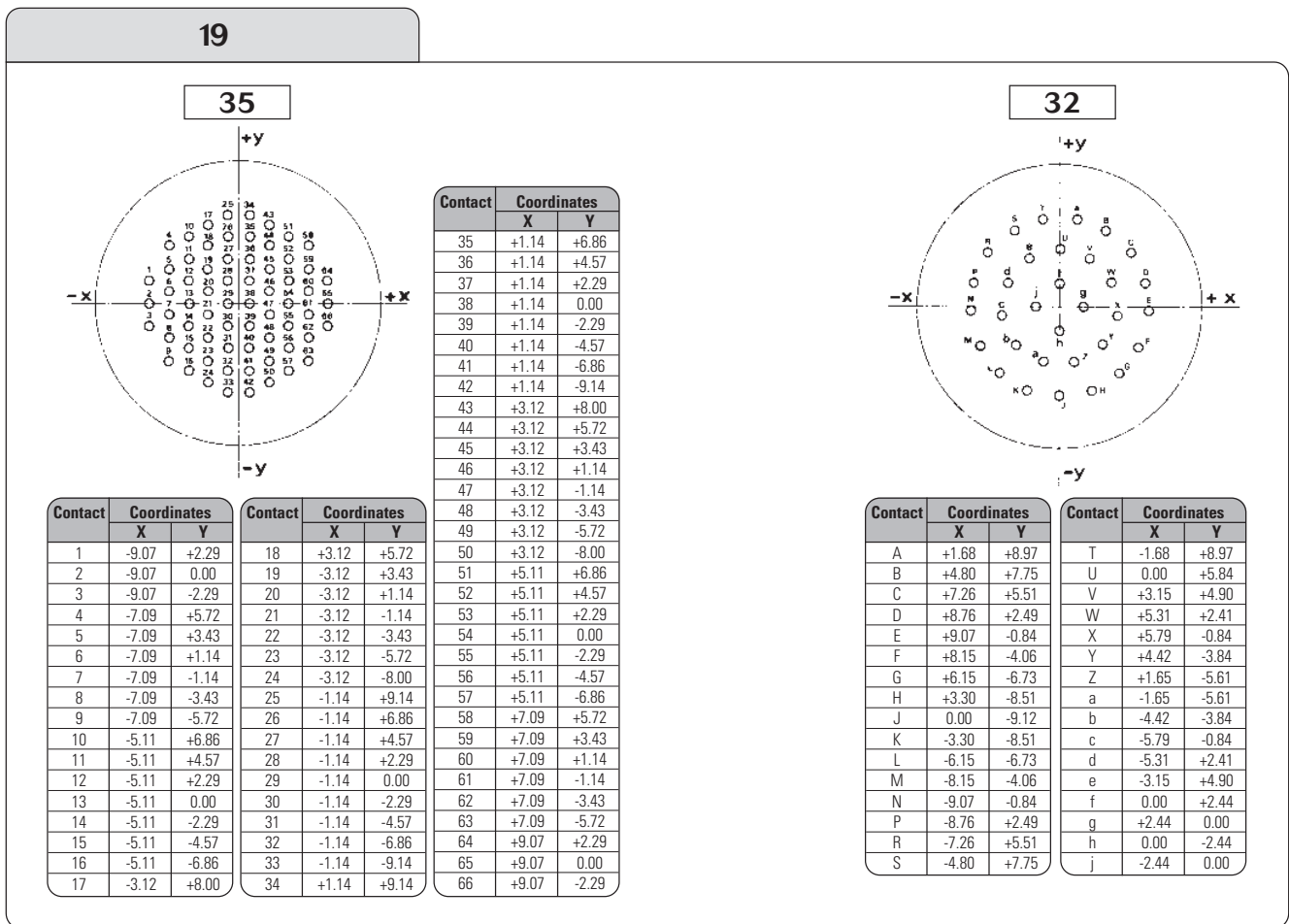
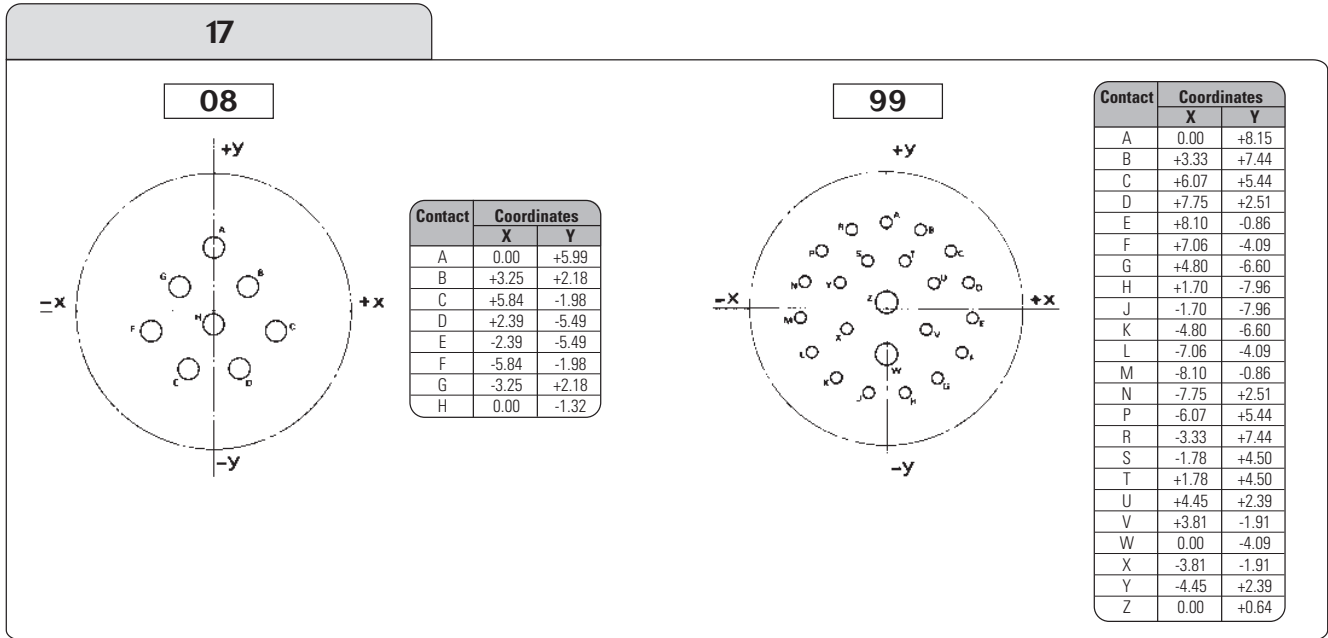

Coordinates for straight spill terminations



19

11

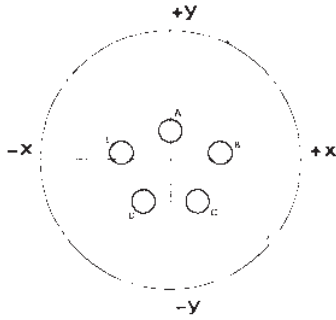

Contact	Coordinates	
	X	Y
A	+2.67	+6.60
B	+6.35	+3.35
C	+6.99	-1.35
D	+4.55	-5.46
E	0.00	-7.14
F	-4.55	-5.46
G	-6.99	-1.35
H	-6.35	+3.35
J	-2.67	+6.60
K	0.00	+2.67
L	0.00	-2.34

21

35

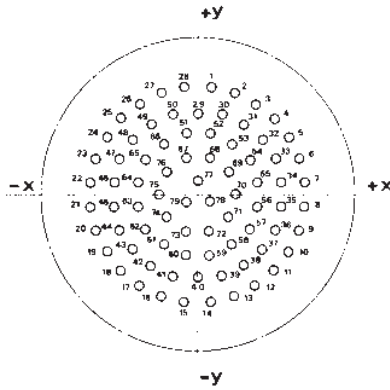

Contact	Coordinates	
	X	Y
41	-2.49	-8.18
42	-4.67	-7.11
43	-6.55	-5.59
44	-7.90	-3.58
45	-8.43	-1.22
46	-8.43	+1.22
47	-7.90	+3.58
48	-6.55	+5.59
49	-4.67	+7.11
50	-2.49	+8.18
51	-1.22	+6.12
52	+1.22	+6.12
53	+3.40	+5.05
54	+5.28	+3.53
55	+6.02	+1.22
56	+6.02	-1.22
57	+5.28	-3.53
58	+3.40	-5.05
59	+1.22	-6.12
60	-1.22	-6.12
61	-3.40	-5.05
62	-5.28	-3.53
63	-6.02	-1.22
64	-6.02	+1.22
65	-5.28	+3.53
66	-3.40	+5.05
67	-1.22	+3.71
68	+1.22	+3.71
69	+3.18	+2.29
70	+3.94	0.00
71	+3.18	-2.29
72	+1.22	-3.71
73	-1.22	-3.71
74	-3.18	-2.29
75	-3.94	0.00
76	-3.18	+2.29
77	0.00	+1.35
78	+1.22	-0.74
79	-1.22	-0.74

Contact	Coordinates		Contact	Coordinates	
	X	Y		X	Y
1	+1.35	+10.82	21	-10.85	-1.22
2	+3.71	+10.26	22	-10.85	+1.22
3	+5.89	+9.19	23	-10.31	+3.58
4	+7.77	+7.67	24	-9.27	+5.77
5	+9.27	+5.77	25	-7.77	+7.67
6	+10.31	+3.58	26	-5.89	+9.19
7	+10.85	+1.22	27	-3.71	+10.26
8	+10.85	-1.22	28	-1.35	+10.82
9	+10.31	-3.58	29	0.00	+8.20
10	+9.27	-5.77	30	+2.49	+8.18
11	+7.77	-7.67	31	+4.67	+7.11
12	+5.89	-9.19	32	+6.55	+5.59
13	+3.71	-10.26	33	+7.90	+3.58
14	+1.35	-10.82	34	+8.43	+1.22
15	-1.35	-10.82	35	+8.43	-1.22
16	-3.71	-10.26	36	+7.90	-3.58
17	-5.89	-9.19	37	+6.55	-5.59
18	-7.77	-7.67	38	+4.67	-7.11
19	-9.27	-5.77	39	+2.49	-8.18
20	-10.31	-3.58	40	0.00	-8.81

39

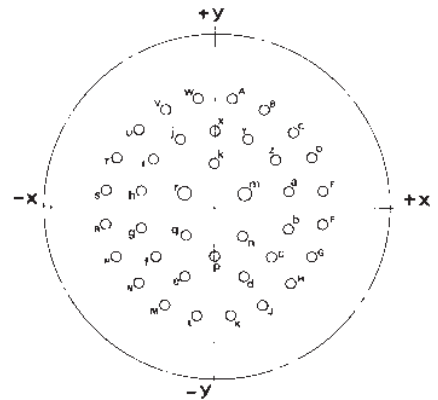

Contact	Coordinates		Contact	Coordinates	
	X	Y		X	Y
A	+1.65	+10.44	X	0.00	+7.49
B	+4.80	+9.42	Y	+3.20	+6.50
C	+7.47	+7.47	Z	+5.89	+4.55
D	+9.42	+4.80	a	+7.11	+1.45
E	+10.44	+1.65	b	+7.11	-1.88
F	+10.44	-1.65	c	+5.51	-4.80
G	+9.42	-4.80	d	+2.84	-6.73
H	+7.47	-7.47	e	-2.84	-6.73
J	+4.80	-9.42	f	-5.51	-4.80
K	+1.65	-10.44	g	-7.11	-1.88
L	-1.65	-10.44	h	-7.11	+1.45
M	-4.80	-9.42	i	-5.89	+4.55
N	-7.47	-7.47	j	-3.20	+6.50
P	-9.42	-4.80	k	0.00	+4.17
R	-10.44	-1.65	m	+2.90	+1.22
S	-10.44	+1.65	n	+2.69	-2.72
T	-9.42	+4.80	p	0.00	-4.80
U	-7.47	+7.47	q	-2.69	-2.72
V	-4.80	+9.42	r	-2.90	+1.22
W	-1.65	+10.44			

Coordinates for straight spill terminations



21

41

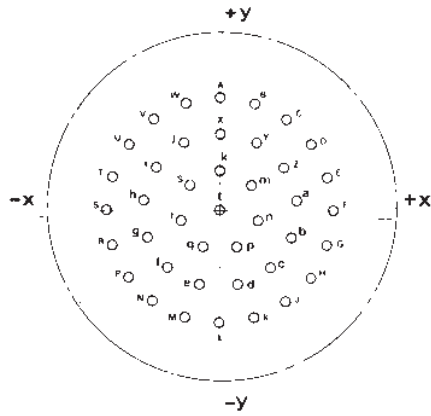

Contact	Coordinates	
	X	Y
T	-10.09	+3.28
U	-8.58	+6.23
V	-6.23	+8.58
W	-3.28	+10.09
X	0.00	+7.20
Y	+3.35	+6.38
Z	+5.92	+4.09
a	+7.15	+0.87
b	+6.73	-2.55
c	+4.78	-5.39
d	+1.73	-6.99
e	-1.73	-6.99
f	-4.78	-5.39
g	-6.73	-2.55
h	-7.15	+0.87
i	-5.92	+4.09
j	-3.35	+6.38
k	0.00	+3.81
m	+2.98	+2.38
n	+3.71	-0.85
p	-1.66	-3.43
q	+1.66	-3.43
r	-3.71	-0.85
s	-2.98	+2.38
t	0.00	0.00

Contact	Coordinates	
	X	Y
A	0.00	+10.60
B	+3.28	+10.09
C	+6.23	+8.58
D	+8.58	+6.23
E	+10.09	+3.28
F	+10.60	0.00
G	+10.09	-3.28
H	+8.58	-6.23

Contact	Coordinates	
	X	Y
J	+6.23	-8.58
K	+3.28	-10.09
L	0.00	-10.60
M	-3.28	-10.09
N	-6.23	-8.58
P	-8.58	-6.23
R	-10.09	-3.28
S	-10.60	0.00

16

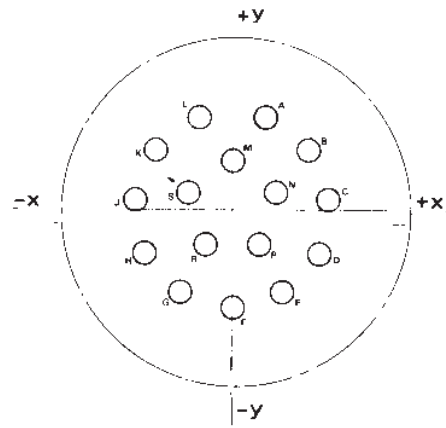

Contact	Coordinates	
	X	Y
A	+3.00	+8.18
B	+6.88	+5.36
C	+8.66	+0.914
D	+7.82	-3.81
E	+4.62	-7.37
F	0.00	-8.71
G	-4.62	-7.37
H	-7.82	-3.81

Contact	Coordinates	
	X	Y
J	-8.66	+0.91
K	-6.88	+5.36
L	-3.00	+8.18
M	0.00	+4.45
N	+3.91	+1.57
P	+2.39	-3.10
R	-2.39	-3.10
S	-3.91	+1.57

Coordinates for straight spill terminations



23

21

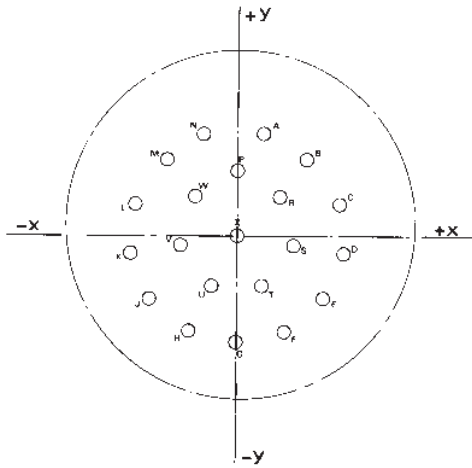

Contact	Coordinates	
	X	Y
A	+3.25	+9.78
B	+7.34	+7.24
C	+9.80	+3.12
D	+10.16	-1.65
E	+8.33	-6.07
F	+4.65	-9.19
G	0.00	-10.31
H	-4.65	-9.19
J	-8.33	-6.07
K	-10.16	-1.65
L	-9.80	+3.12

Contact	Coordinates	
	X	Y
M	-7.34	+7.24
N	-3.25	+9.78
P	0.00	+6.22
R	+4.06	+3.71
S	+5.44	-0.89
T	+2.39	-4.93
U	-2.39	-4.93
V	-5.44	-0.89
W	-4.06	+3.71
X	0.00	0.00

53

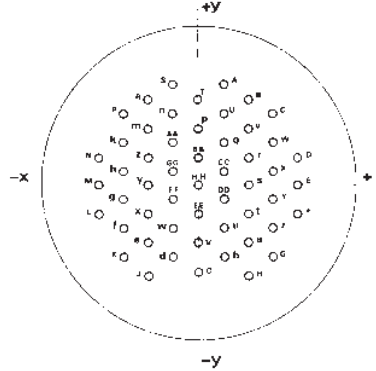

Contact	Coordinates	
	X	Y
A	+4.98	+12.70
B	+7.98	+11.05
C	+10.49	+8.71
D	+12.32	+5.84
E	+13.39	+2.57
F	+13.61	-0.76
G	+12.98	-4.17
H	+11.53	-7.29
J	+9.35	-9.93
K	+6.58	-11.94
L	+3.40	13.18
M	0.00	-13.64

Contact	Coordinates	
	X	Y
N	-3.40	-13.18
P	-6.58	-11.94
R	-9.35	-9.93
S	-11.53	-7.29
T	-12.98	-4.17
U	-13.61	-0.76
V	-13.39	+2.57
W	-12.32	+5.84
X	-10.49	+8.71
Y	-7.98	+11.05
Z	-4.98	12.70

Contact	Coordinates	
	X	Y
a	-1.73	+11.53
b	+1.73	+11.53
c	+4.39	+9.22
d	+7.24	+7.19
e	+9.19	+4.45
f	+10.13	+1.17
g	+9.96	-2.24
h	+8.66	-5.41
i	+6.38	-7.98
j	+3.38	-9.63
k	0.00	-10.21
m	-3.38	-9.63
n	-6.38	-7.98
p	-8.66	-5.41
q	-9.96	-2.24
r	-10.13	+1.17
s	-9.19	+4.45
t	-7.24	+7.19
u	-4.39	+9.22
v	0.00	+8.59
w	+3.73	+5.66
x	+6.02	+3.10
y	+6.78	-0.25
z	+5.79	-3.53
AA	+3.33	-5.92
BB	0.00	-6.78
CC	-3.33	-5.92
DD	-5.79	-3.53
EE	-6.78	-0.25
FF	-6.02	+3.10
GG	-3.73	+5.66
HH	0.00	+5.08
JJ	+2.67	+2.39
KK	+3.43	-1.04
LL	0.00	-3.35
MM	-3.43	-1.04
NN	-2.67	+2.39
PP	0.00	0.00

Coordinates for straight spill terminations



25

04

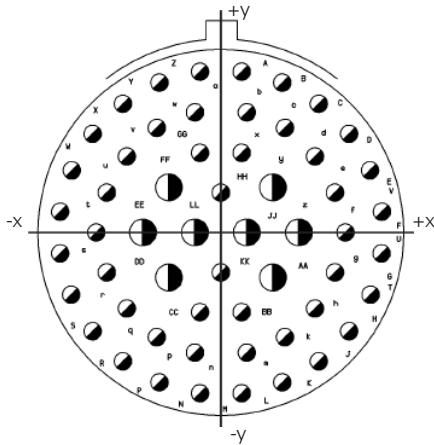

Contact	Coordinates	
	X	Y
A	+1.75	+13.49
B	+5.49	+12.57
C	+8.23	+10.80
D	+10.77	+8.28
E	+12.52	+5.21
F	+13.49	+1.75
G	+13.49	-1.75
H	+12.52	-5.21
J	+10.77	-8.28
K	+8.23	-10.80
L	+5.16	-12.57
M	+1.75	-13.49
N	-1.75	-13.49
P	-5.16	-12.57
R	-8.23	-10.80
S	-10.77	-8.28
T	-12.52	-5.21
U	-13.49	-1.75
V	-13.49	+1.75
W	-12.52	+5.21
X	-10.77	+8.28
Y	-8.23	+10.80
Z	-5.16	+12.57

Contact	Coordinates	
	X	Y
a	-1.75	+13.49
b	+2.18	+10.08
c	+5.38	+8.78
d	+7.90	+6.38
e	+9.58	+3.35
f	+10.46	0.00
g	+9.58	-3.35
h	+7.90	-6.38
k	+5.38	-8.78
m	+2.18	-10.08
n	-2.18	-10.08
p	-5.38	-8.78
q	-7.90	-6.38
r	-9.58	-3.35
s	-10.46	0.00
t	-9.58	+3.35
u	-7.90	+6.38
v	-5.38	+8.78
w	-2.18	+10.08
x	+1.75	+6.66
y	+4.37	+3.78
z	+6.55	0.00

Contact	Coordinates	
	X	Y
AA	+4.37	-3.78
BB	+1.75	-6.66
CC	-1.75	-6.66
DD	-4.37	+3.78
EE	-6.55	0.00
FF	-4.37	+3.78
GG	-1.75	+6.66
HH	0.00	+3.35
JJ	+2.18	0.00
KK	0.00	-3.35
LL	+2.18	0.00

29

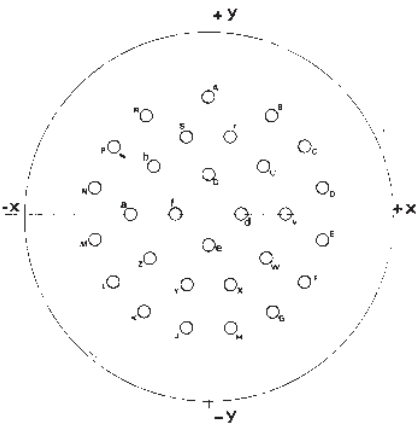

Contact	Coordinates	
	X	Y
A	0.00	-12.22
B	+6.55	+10.31
C	+10.03	+7.04
D	+11.91	+2.77
E	+11.91	-2.77
F	+10.03	-7.04
G	+6.68	-10.31
H	+2.31	-11.99
J	-2.31	-11.99
K	-6.68	-10.31
L	-10.03	-7.04
M	-11.91	-2.77
N	-11.91	+2.77
P	-10.03	+7.04

Contact	Coordinates	
	X	Y
R	-6.55	+10.31
S	-2.31	+8.15
T	+2.31	+8.15
U	+5.79	+4.93
V	+8.10	0.00
W	+6.10	-4.60
X	+2.31	-7.37
Y	-2.31	-7.37
Z	-6.10	-4.60
a	-8.10	0.00
b	-5.79	+4.93
c	0.00	+4.09
d	+3.40	0.00
e	0.00	-3.30
f	-3.40	0.00

35

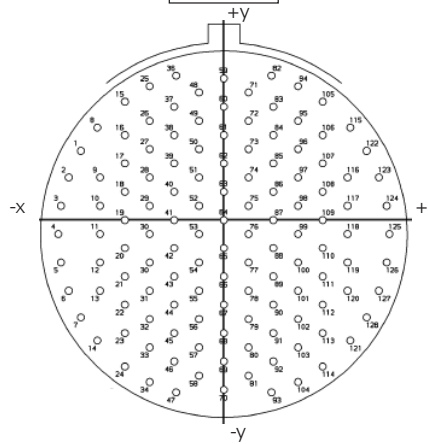

Contact	Coordinates	
	X	Y
A	+4.98	+12.70
B	+7.98	+11.05
C	+10.49	+8.71
D	+12.32	+5.84
E	+13.39	+2.57
F	+13.61	-0.76
G	+12.98	-4.17
H	+11.53	-7.29
J	+9.35	-9.93
K	+6.58	-11.94
L	+3.40	13.18

Contact	Coordinates	
	X	Y
M	0.00	-13.64
N	-3.40	-13.18
P	-6.58	-11.94
R	-9.35	-9.93
S	-11.53	-7.29
T	-12.98	-4.17
U	-13.61	-0.76
V	-13.39	+2.57
W	-12.32	+5.84
X	-10.49	+8.71
Y	-7.98	+11.05
Z	-4.98	+12.70

Contact	Coordinates	
	X	Y
a	-1.73	+11.53
b	+1.73	+11.53
c	+4.39	+9.22
d	+7.24	+7.19
e	+9.19	+4.45
f	+10.13	+1.17
g	+9.96	-2.24
h	+8.66	-5.41
i	+6.38	-7.98
j	+3.38	-9.63
k	0.00	-10.21
m	-3.38	-9.63
n	-6.38	-7.98
p	-8.66	-5.41
q	-9.96	-2.24
r	-10.13	+1.17
s	-9.19	+4.45
t	-7.24	+7.19
u	-4.39	+9.22
v	0.00	+8.59
w	+3.73	+5.66
x	+6.02	+3.10
y	+6.78	-0.25
z	+5.79	-3.53
AA	+3.33	-5.92
BB	0.00	-6.78
CC	-3.33	-5.92
DD	-5.79	-3.53
EE	-6.78	-0.25
FF	-6.02	+3.10
GG	-3.73	+5.66
HH	0.00	+5.08
JJ	+2.67	+2.39
KK	+3.43	-1.04
LL	0.00	-3.35
MM	-3.43	-1.04
NN	-2.67	+2.39
PP	0.00	0.00

Coordinates for straight spill terminations



25

43

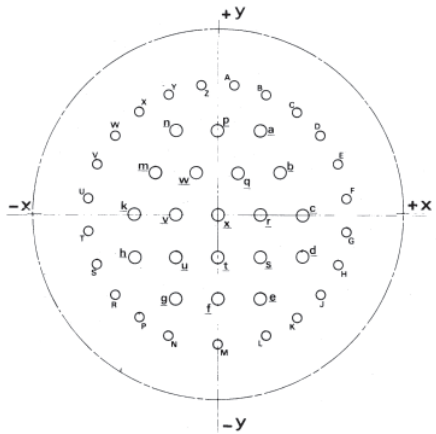

Contact	Coordinates	
	X	Y
A	+1.75	+13.49
B	+5.16	+12.57
C	+8.23	+10.80
D	+10.77	+8.28
E	+12.52	+5.21
F	+13.49	+1.75
G	+13.49	-1.75
H	+12.52	-5.21
J	+10.77	-8.28
K	+8.23	-10.80
L	+5.16	-12.57
M	0.00	-13.49
N	-5.16	-12.57
P	-8.23	-10.80
R	-10.77	-8.28
S	-12.52	-5.21
T	-13.49	-1.75
U	-13.49	+1.75
V	-12.52	+5.21
W	-10.77	+8.28
X	-8.23	+10.80
Y	-5.16	+12.57
Z	-1.75	+13.49

Contact	Coordinates	
	X	Y
a	+4.37	+8.74
b	+6.55	+4.37
c	+8.74	0.00
d	+8.74	-4.37
e	+4.37	-8.74
f	0.00	-8.74
g	-4.37	-8.74
h	-8.74	-4.37
k	-8.74	0.00
m	-6.55	+4.37
n	-4.37	+8.74
p	0.00	+8.74
q	+2.18	+4.37
r	+4.37	0.00
s	+4.37	-4.37
t	0.00	-4.37
u	-4.37	-4.37
v	-4.37	0.00
w	-2.18	+4.37
x	0.00	0.00

61

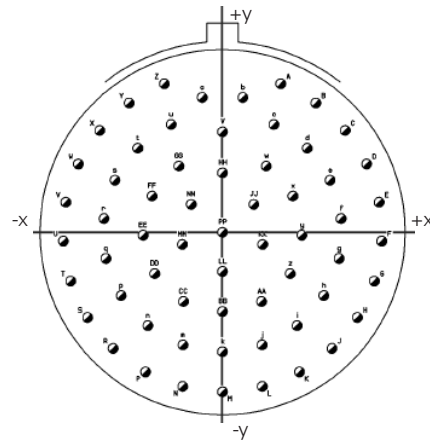

Contact	Coordinates	
	X	Y
A	+4.98	+12.70
B	+7.98	+11.05
C	+10.49	+8.71
D	+12.32	+5.84
E	+13.39	+2.57
F	+13.61	-0.76
G	+12.98	-4.17
H	+11.53	-7.29
J	+9.35	-9.93
K	+6.58	-11.94
L	+3.40	-13.18
M	0.00	-13.64
N	-3.40	-13.18
P	-6.58	-11.94
R	-9.35	-9.93
S	-11.53	-7.29
T	-12.98	-4.17
U	-13.61	-0.76
V	-13.39	+2.57
W	-12.32	+5.84
X	-10.49	+8.71
Y	-7.98	+11.05
Z	-4.98	+12.70

Contact	Coordinates	
	X	Y
a	-1.73	+11.53
b	+1.73	+11.53
c	+4.39	+9.22
d	+7.24	+7.19
e	+9.19	+4.45
f	+10.13	+1.17
g	+9.96	-2.24
h	+8.66	-5.41
i	+6.38	-7.98
k	0.00	-10.21
m	-3.38	-9.63
n	-6.38	-7.98
p	-8.66	-5.41
q	-9.96	-2.24
r	-10.13	+1.17
s	-9.19	+4.45
t	-7.24	+7.19
u	-4.39	+9.22
v	0.00	+8.59
w	+3.73	+5.66
x	+6.02	+3.10
y	+6.78	-0.25
z	+5.79	-3.53
AA	+3.33	-5.92
BB	0.00	-6.78
CC	-3.33	-5.92
DD	-5.79	-3.53
EE	-6.78	-0.25
FF	-6.02	+3.10
GG	-3.73	+5.66
HH	0.00	+5.08
JJ	+2.67	+2.39
KK	+3.43	-1.04
LL	0.00	-3.35
MM	-3.43	-1.04
NN	-2.67	+2.39
PP	0.00	0.00



www.souriau.com

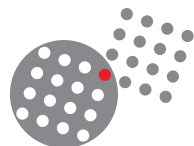

SOURIAU
Connection Technology