

a) Part as supplied.

KTKK 0510-0518

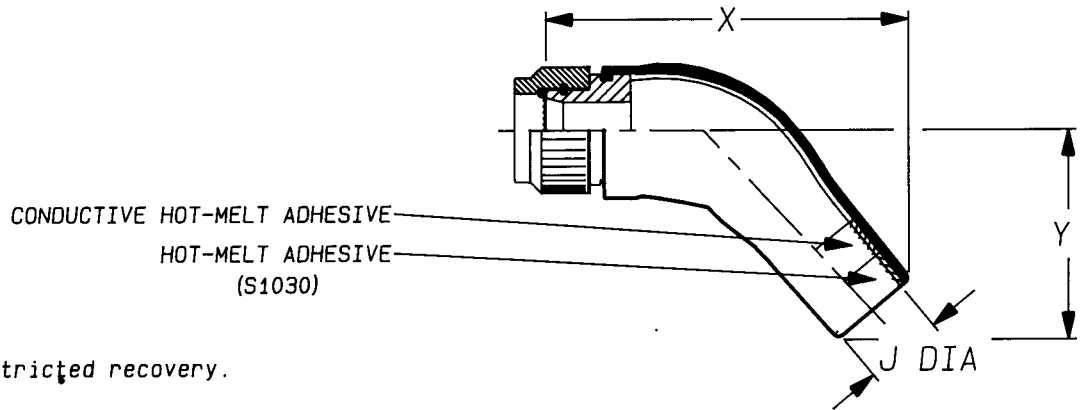

b) Part after unrestricted recovery.

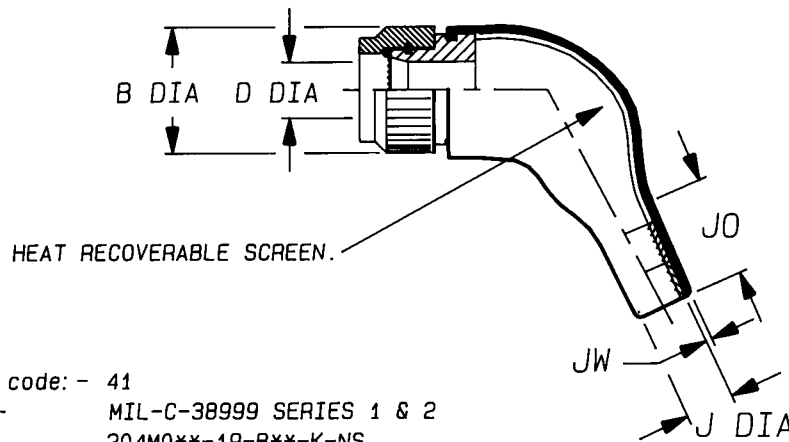

Raychem connector code: - 41
 Connector Series: - MIL-C-38999 SERIES 1 & 2
 Adaptor Series: - 204M0**-19-B**-K-NS
 Moulded Part Material: - -25S

Kits to include cleaning tissue, 1 piece 100 grit emery cloth & packing piece.
 Kit to be used in conjunction with installation guide for 90 & 45 deg. assemblies.

Dimensions (in millimetres.)

Part No.	SHELL SIZE	B	D	J		JO	JW	X	Y
		DIA MAX	DIA MIN	MIN a	MAX b	REF b	±30% b	±20% a	±20% a
KTKK 0510	08	19.2	6.2	7	5.0	15	1.0	60	23
KTKK 0511	10	21.7	9.3	9	6.0	17	1.0	67	29
KTKK 0512	12	25.5	12.9	11	7.2	18	1.0	73	29
KTKK 0513	14	28.0	14.1	11	7.2	18	1.0	73	29
KTKK 0514	16	31.9	18.8	17	8.5	20	1.0	83	36
KTKK 0515	18	35.7	18.8	17	8.5	20	1.0	83	36
KTKK 0516	20	38.2	23.6	21	10.0	28	1.5	100	45
KTKK 0517	22	42.0	23.6	21	10.0	28	1.5	100	45
KTKK 0518	24	44.6	31.1	29	15.8	31	1.5	121	59

Copyright (!)
 Urheberrechte

The copyright in this drawing is the property of Raychem Ltd. The drawing is issued on condition that it is not copied, reproduced or disclosed to a third party, either in whole or in part without the prior written consent of Raychem Ltd.

Drawn A.LILLEY. Checked *KL* Issue 3 Date September 1995 Conforms to ISO Recommendations
 3rd Angle Projection
 Not to Scale

Approval
 Design AARS.
 MKTG. *DC*
 G.C. *MS*

