

DRAWING MADE IN THIRD ANGLE PROJECTION

THIS DRAWING IS UNPUBLISHED. RELEASED FOR PUBLICATION, 19 .
 © COPYRIGHT 19 BY AMP INCORPORATED. ALL INTERNATIONAL RIGHTS RESERVED.

MOD	LOC	DIST	P	F	ZONE	LTR	DESCRIPTION	DATE	APPD
2	BD	36				0	RELEASED	01/23/91	-
						01	ADDED -9 NPR 4784 WAS 93-5034-1	05/13/93	RK
						A	REV PER EC 0020-1470-93	01/03/94	TC

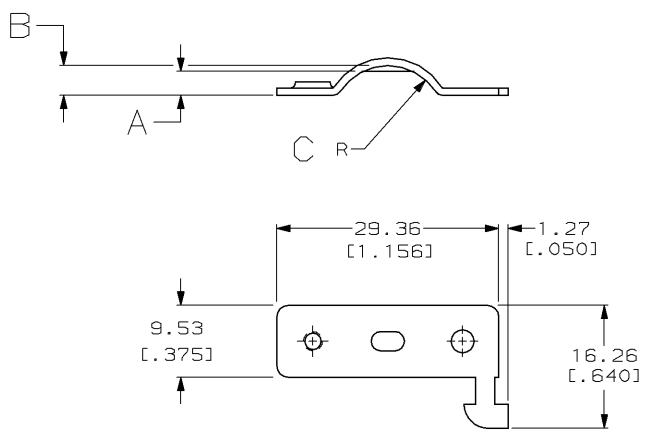

8.89 [.350]	3.07 [.121]	2.29 [.090]	201162-9
7.54 [.297]	3.96 [.156]	3.18 [.125]	201162-7
5.54 [.218]	5.54 [.218]	5.08 [.200]	201162-4

		C	B	A	PART NO
DO NOT SCALE PRINT. UNLESS SPECIFIED DIMENSIONS IN mm [INCHES] TOLERANCES ON: 2 PLC DEC ± 0.13 [.005] 3 PLC DEC ± - ANGLES ± -		DR 01/23/91 L. SUIPE		AMP AMP Incorporated Harrisburg, PA 17105-3608	
MATERIAL CARBON STEEL		CHK 1-25-91 W. LENKER		NAME CABLE CLAMP, 34 PLACE SHIELD, M SERIES	
FINISH 5.08µm [.000200] MIN NICKEL		APPD 1-31-91 R. WALTER		SIZE B	
		PRODUCT SPEC -		CAGE CODE 00779	
		APPLICATION SPEC -		DRAWING NO 201162	
		WEIGHT -		SCALE 2:1	
				SHEET 1 OF 1	

AMP 1470-15 REV 11-89
 03 JAN 1994 09:00:40 AMP34723 <U5026B>DEPT4023>AMP34723>U.1470

CUSTOMER DRAWING