

THIS DRAWING IS UNPUBLISHED. RELEASED FOR PUBLICATION. ALL RIGHTS RESERVED.

REV	DATE	BY	APPROV
C1	11MAR2011	AK	HMA
DESCRIPTION: REVISED PER ECO-11-004820			

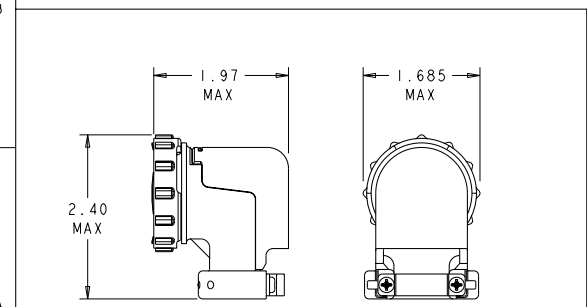
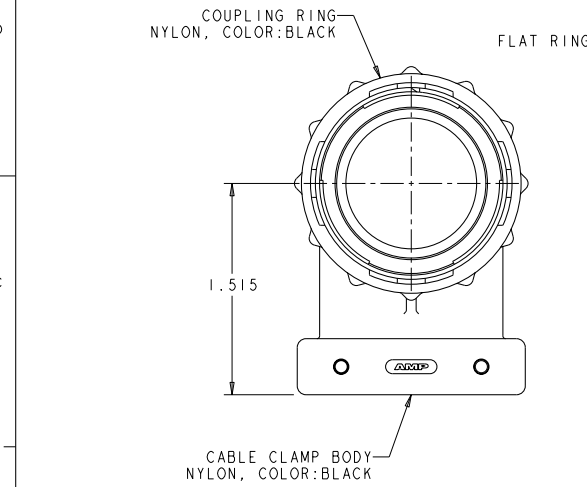

ASSEMBLED VIEW  
SCALE: 1:1

- ⚠ SELF TAPPING SCREWS AND CABLE CLAMP INSERTS PACKAGED UNASSEMBLED.
- ⚠ CLAMPING AREA ADJUSTABLE TO .703 O.D. MAX CABLE. CABLE CLAMP INSERTS CAN BE ADJUSTED BY INVERTING OR CHANGING CABLE CLAMP INSERT.
- ⚠ SCREW FINISH ZINC WITH NON HEXAVALENT CHROMATE.

SUPERSEDED BY - 2	1546350-2
	1546350-1
	PART NUMBER

THIS DRAWING IS A CONTROLLED DOCUMENT.		DATE: 13AUG2002	
DRAWN BY: S. WELDON		DATE: 13AUG2002	
CHECKED BY: S. BEAVER		DATE: 13AUG2002	
DIMENSIONS: INCHES		PRODUCT SPEC: S. BEAVER	NAME: CABLE CLAMP KIT, UNASSEMBLED, R/A, W/COVER, SIZE 23, CPC
TOLERANCES UNLESS OTHERWISE SPECIFIED:		APPLICATION SPEC:	SIZE: A2
0 PLC	±.01	WEIGHT:	CASE CODE: 00779
1 PLC	±.02	CUSTOMER DRAWING:	DRAWING NO: 1546350
2 PLC	±.03		RESTRICTED TO:
3 PLC	±0.005		
4 PLC	±.05		
ANGLES	±.01		
FINISH			
		SCALE: 2:1	SHEET 1 OF 1