

4

3

2

1

THIS DRAWING IS UNPUBLISHED. RELEASED FOR PUBLICATION
 © COPYRIGHT - By - ALL RIGHTS RESERVED.

LOC	DIST	REVISIONS			
P	LTR	DESCRIPTION	DATE	DWN	APVD
FT	0				
	A2	REVISED PER ECO-11-004917	11MAR11	RK	HMR

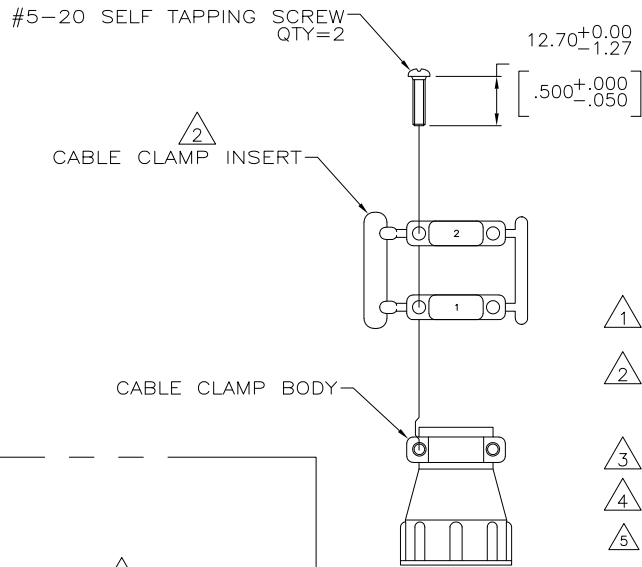

- 1 CABLE CLAMP BODY AND INSERTS: NYLON, BLACK. SCREWS: CARBON STEEL.
- 2 CABLE CLAMPING AREA ADJUSTABLE FROM 0.25 [.010] TO 4.09 [.161] SQ AREA BY REVERSING OR CHANGING CLAMPING INSERTS.
- 3 11.51 [.453] MAXIMUM CABLE OUTSIDE DIAMETER.
- 4 SCREWS: ZINC PLATE, NON-HEXAVALENT COATING.
- 5 OBSOLETE PARTS: OBSOLETE CIS STREAMLINING PER D.RENAUD/D.SINISI

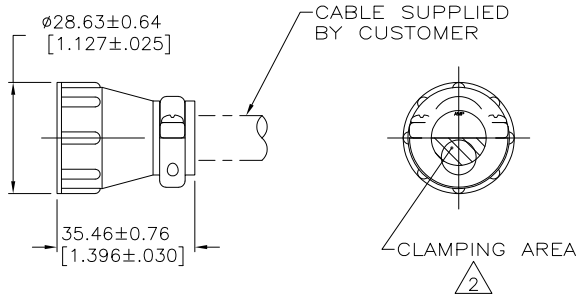

ASSEMBLED VIEW

5 SUPERSEDED	4	BULK	213904-4
	4	INDIVIDUAL	213904-3
	4	BULK	213904-2
	4	INDIVIDUAL	213904-1
	SCREW FINISH	PACKAGING	PART NUMBER

THIS DRAWING IS A CONTROLLED DOCUMENT.		DWN D.HARDY 07/12/95	STE TE Connectivity	
DIMENSIONS: mm [INCHES]		CHK R.STONE 07/13/95		
TOLERANCES UNLESS OTHERWISE SPECIFIED:		APVD A.FRANTUM 07/14/95	NAME	
0 PLC ± -		PRODUCT SPEC	CABLE CLAMP KIT, STANDARD, UNASSEMBLED, SIZE 17, CPC	
1 PLC ± -		108-1579	SIZE CAGE CODE DRAWING NO	
2 PLC ± -		APPLICATION SPEC	A3	00779 C-213904
3 PLC ± -		WEIGHT -	RESTRICTED TO	
4 PLC ± -		MATERIAL 1	CUSTOMER DRAWING	
ANGLES ± -		FINISH -	SCALE 1:1	SHEET 1 OF 1
			REV A2	