

DATE WITH: PASSEND ZU:	LOC A1	DIST -	REVISIONS AENDERUNGEN					
PROJEKT NR.: EGLPC01017			P	LTR	DESCRIPTION BESCHREIBUNG	DATE	DWN	APVD
				A1	EG00-1033-01	11JUN2001	NG	GF

NOTES:

- 1 BRASS
- 2 MIN. ORDER QUANTITY: 250 PCS.

BEMERKUNGEN:

- 1 MESSING
- 2 MINDESTBESTELLMENGE: 250 STK.

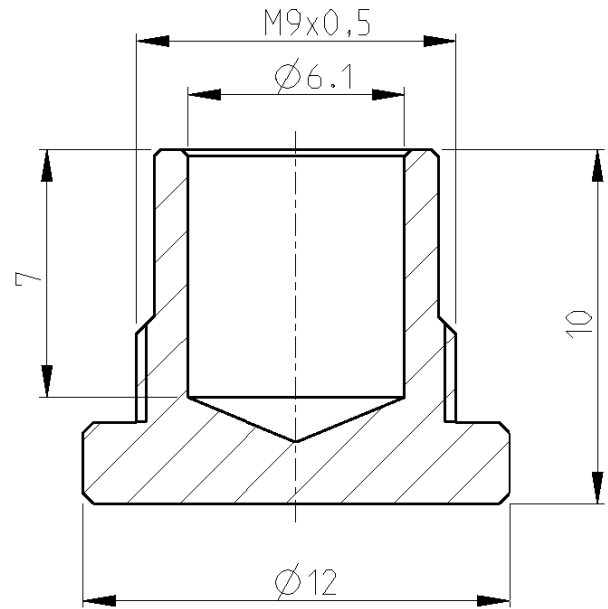
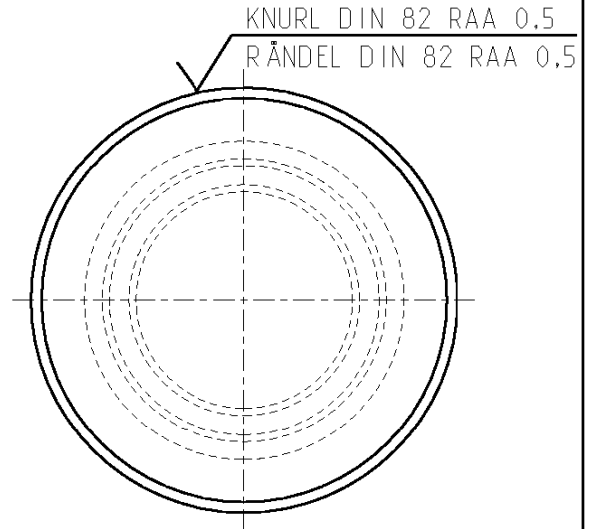

T01-0500-S	0-1437719-8
CAT.-NO. / KAT.-NR.	TYCO-NO. / TYCO-NR.

RELEASED FOR PUBLICATION 24-JUL-2001  
 FREI FÜR VERÖFFENTLICHUNG  
 ALL RIGHTS RESERVED  
 BY TYCO ELECTRONICS CORPORATION  
 VERTRÄGLICHE UNVERÖFFENTLICHUNG  
 © COPYRIGHT 2001

DIMENSIONS: MASSEINHEITEN: mm	DWN N.GEISTER	11JUN2001	MATERIAL	- 1	FINISH OBERFLÄCHE/FARBE	-								
	CHK H.SCHERER	11JUN2001	tyco Electronics AMP GmbH D - 64625 Bensheim											
TOLERANCES UNLESS OTHERWISE SPECIFIED: ALLGEMEINTOLERANZEN	APVD G.FELDMEIER	11JUN2001	NAME T01 MALE SCREWING TUBE, METAL T01 SCHRAUBKAPPE BUCHSE, METALL											
	PRODUCT SPEC PRODUKTSPEZ.	-	SIZE	A 4	CAGE CODE	00779	DRAWING NO ZEICHNUNGS-NR.	C=1437719-8	RESTRICTED TO NUR FUER	-				
0 PLC ± 1 PLC ± 2 PLC ± 3 PLC ± 4 PLC ± ANGLES/WINKEL ±°	APPLICATION SPEC VERARBEITUNGSSPEZ.	-	CUSTOMER DRAWING		/KUNDENZEICHNUNG		SCALE MASSSTAB	5:1	SHEET BLATT	1	OF VON	1	REV	A1