

| REV | DATE | DESCRIPTION | BY | CHK | APP |
|-----|------|----------------------|--------|-----|-----|
| AD | 00 | REV PER 0652-0070-99 | 043666 | BH | NM |

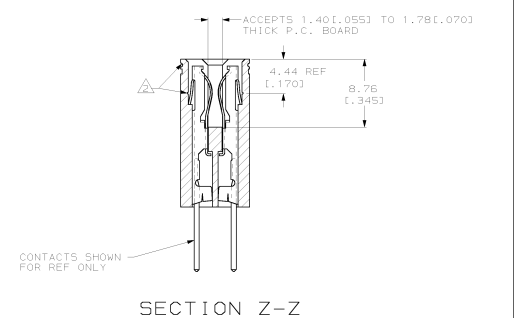
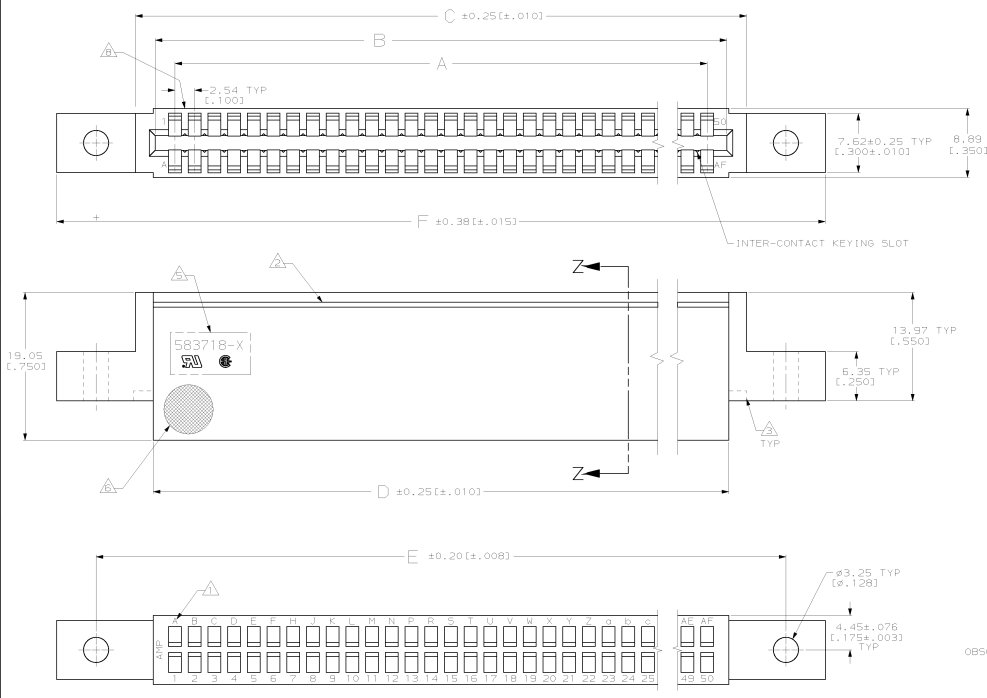

- ▲ FIRST 22 POSITIONS MARKED WITH UPPER CASE LETTERS, FOLLOWED BY LOWER CASE LETTERS, FOLLOWED BY UPPERCASE AA, AB, AC ETC. CHARACTERS G, I, O AND Q ARE OMITTED. SEE TABLE FOR END CAVITY IDENTIFICATION.
- ▲ OPTIONAL PULL GROOVES. THE PULL GROOVE LENGTH, SIZE AND LOCATION ARE AT THE DISCRETION OF THE MOLD VENDOR.
- ▲ CORING AT AMP'S OPTION REF ONLY.
- ▲ SAME AS 583718-9 EXCEPT SPECIAL MARKING SEE SHEET 2 FOR DETAIL.
- ▲ HOUSING PART NUMBER, UL & CSA LOGO'S TO BE MOLDED IN THIS AREA. UL, LOGO PER 1-18839-3, CSA LOGO PER 1-18839-3.
- ▲ STAMP .250±.015 DIA DOT ON LOWER LEFT HAND CORNER SAME SIDE AS AMP PART NUMBER AND DATE CODE.
- ▲ SAME AS 1-583718-7 EXCEPT SPECIAL MARKING SEE SHEET 2 FOR DETAIL.
- ▲ DATE CODE TO BE MOLDED IN THIS AREA

| | | | | | | | | |
|---------|--------|--------|--------|--------|--------|--------|----|------------|
| 50 & AF | 154.94 | 141.61 | 130.05 | 134.62 | 129.54 | 124.46 | 50 | 3-583718-7 |
| 18 & V | 73.66 | 63.50 | 48.77 | 53.34 | 48.26 | 43.18 | 18 | 583718-7 |
| 32 & L | 103.22 | 99.05 | 84.33 | 88.90 | 71.12 | 65.04 | 32 | 2-583718-7 |
| 40 & V | 129.54 | 119.38 | 104.65 | 109.22 | 104.14 | 99.06 | 40 | 2-583718-6 |
| 22 & Z | 83.82 | 73.66 | 58.93 | 63.50 | 58.42 | 53.34 | 22 | 2-583718-5 |
| 30 & J | 91.44 | 81.28 | 66.55 | 71.12 | 66.04 | 60.96 | 30 | 2-583718-4 |
| 15 & S | 66.04 | 55.88 | 41.15 | 45.72 | 40.64 | 35.56 | 15 | 2-583718-3 |
| 22 & Z | 83.82 | 73.66 | 58.93 | 63.50 | 58.42 | 53.34 | 22 | 2-583718-2 |
| 25 & C | 91.44 | 81.28 | 66.55 | 71.12 | 66.04 | 60.96 | 25 | 2-583718-1 |
| 50 & AF | 154.94 | 141.61 | 130.05 | 134.62 | 129.54 | 124.46 | 50 | 1-583718-7 |
| 40 & V | 129.54 | 119.38 | 104.65 | 109.22 | 104.14 | 99.06 | 40 | 1-583718-5 |
| 30 & J | 91.44 | 81.28 | 66.55 | 71.12 | 66.04 | 60.96 | 30 | 1-583718-3 |
| 25 & C | 91.44 | 81.28 | 66.55 | 71.12 | 66.04 | 60.96 | 25 | 1-583718-1 |
| 22 & Z | 83.82 | 73.66 | 58.93 | 63.50 | 58.42 | 53.34 | 22 | 583718-9 |
| 18 & V | 73.66 | 63.50 | 48.77 | 53.34 | 48.26 | 43.18 | 18 | 583718-7 |
| 17 & U | 71.12 | 60.96 | 46.23 | 50.80 | 45.72 | 40.64 | 17 | 583718-5 |
| 15 & S | 66.04 | 55.88 | 41.15 | 45.72 | 40.64 | 35.56 | 15 | 583718-3 |
| 10 & L | 53.34 | 43.18 | 28.45 | 33.02 | 27.94 | 22.86 | 10 | 583718-1 |

| END CAVITY IDENT | F | E | D | C | B | A | POSN | PART NUMBER |
|------------------|---|---|---|---|---|---|------|-------------|
| 50 & AF | | | | | | | 50 | 1-583718-7 |
| 40 & V | | | | | | | 40 | 1-583718-5 |
| 30 & J | | | | | | | 30 | 1-583718-3 |
| 25 & C | | | | | | | 25 | 1-583718-1 |
| 22 & Z | | | | | | | 22 | 583718-9 |
| 18 & V | | | | | | | 18 | 583718-7 |
| 17 & U | | | | | | | 17 | 583718-5 |
| 15 & S | | | | | | | 15 | 583718-3 |
| 10 & L | | | | | | | 10 | 583718-1 |

THIS DRAWING IS A CONTROLLED DOCUMENT. FOR ADDITIONAL INFORMATION, CONTACT THE DRAWING ENGINEER.

AMP Incorporated
 Harrisburg, PA 17105-8608

HOUSING, CRIMP SNAP TWIN LEAF
 .100", WITH MOUNTING EARS

DATE: 06/27/99
 DRAWN BY: J. J. [Signature]
 CHECKED BY: [Signature]

