

REV. P

NOTES:

1. PUSHOUT FORCE TO BE 20 OZ. MIN.
2. IN RIGHT ANGLE VERSION LOGO SIDE OF HEADER SHOULD BE LOCATED OPPOSITE RIGHT ANGLE TAIL AND CARRIER SIDE OF CONTACT AS SHOWN.
3. ($\text{\textcircled{C}}$) REPRESENTS CRITICAL DIMENSION.

DIMENSIONS ARE IN INCHES		UNLESS OTHERWISE NOTED		TOLERANCES ARE:		TITLE:	DWG NO:
ONE PLACE DECIMALS ±	TWO PLACE DECIMALS ±	THREE PLACE DECIMALS ± .005	FOUR PLACE DECIMALS ±	ANGLES	± 2°	STAMPED CONTACT STRIP ASSEMBLY	SSK-1XX-S-X-XX
						SHEET 1 OF 1	

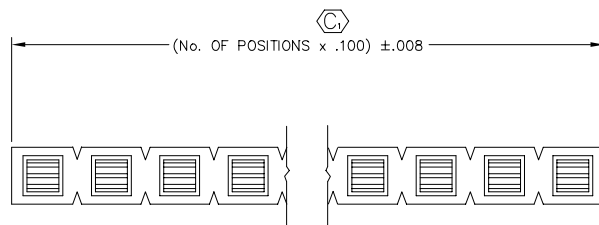

POSITION SPECIFICATION
36 POSITIONS MAX

SSK-1XX-S-X-XX

OPTION
RA: SEE TABLE 1

TERMINATION
-S SOLDER

PLATING SPECIFICATION
-G: GOLD - USE C-12-G
-T: TIN - USE C-12-T

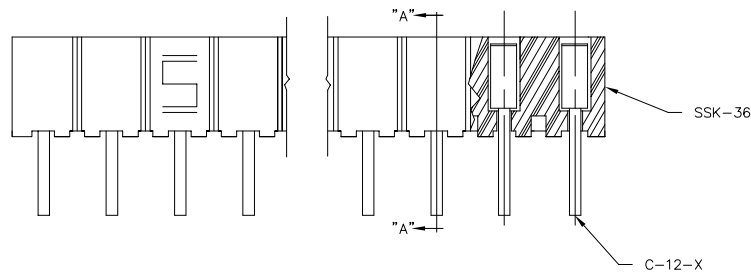

SECTION "A-A"
(ALSO IN-PROCESS FOR -RA OPTION)

TABLE 1

OPTIONS
(SEE NOTE 2)

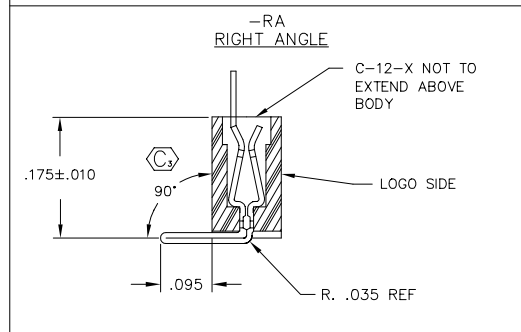

Do not scale
from this print

PROPRIETARY NOTE
THIS DOCUMENT CONTAINS INFORMATION CONFIDENTIAL AND PROPRIETARY TO SAMTEC INC. AND SHALL NOT BE REPRODUCED OR TRANSMITTED TO OTHER DOCUMENTS OR DISCLOSED TO OTHERS OR USED FOR ANY PURPOSE OTHER THAN THAT FOR WHICH IT WAS OBTAINED WITHOUT THE EXPRESS WRITTEN CONSENT OF SAMTEC INC.

samtec

MISC/MKT0
SSK-MKT

520 PARK EAST BLVD. NEW ALBANY, INDIANA 47150
PHONE (812) 944-6733 P.O. BOX 1147
CODE 55322

MADE BY: PURVIS 7-2-84
CHECKED BY: TM HAHN

ENG. APPROVAL

SSK-1XX-S-X-XX
SHEET 1 OF 1