

REV. AS

NOTES:

1. COPLANARITY TO BE WITHIN .004.
2. MINIMUM PUSHOUT FORCE: 1 LB.
3. TAILS TO BE SHEARED TO THE DIMENSION AS SHOWN, .003 [.08] MAX BURR.
4. .010 [.25] MAX CUT FLASH.
5. FOR -XX POSITION ASSEMBLY USE -XX POSITION BODY EXCEPT AS LISTED IN TABLE 2
6. IF -A ON ASSEMBLY, USE -A ON END OF BODY CALLOUT FTE-190-0X-G-DV-SA FOR STOCK THAT WILL BE CUT FOR STAKED -A ORDERS. FTE-190-0X-G-DV FOR ORDERS NOT REQUIRING STAKED -A.
7. .020 ATTACHED MAX FLASH ALLOWED ON THIS SURFACE OF BODY, POST SIDE ONLY.

DIMENSIONS ARE IN INCHES		UNLESS OTHERWISE NOTED		TOLERANCES ARE:		TITLE:		DWG NO:	
ONE PLACE DECIMALS ±.1[.25]		THREE PLACE DECIMALS ±.005[.13]		ANGLES ± 2°		.8MM x 1.2MM C.L. TERMINAL STRIP ASSM		FTE-1XX-XX-X-DV-XX-XX	
TWO PLACE DECIMALS ±.01[.3]		FOUR PLACE DECIMALS ±.0020[.051]						SHEET 1 OF 3	

DO NOT SCALE FROM THIS PRINT

ASSEMBLY	BODY
FTE-1XX-01-G-DV-ES-XX (SEE NOTES 5 AND 6)	FTE-90-D-ES-XX-X (SEE NOTES 5 AND 6)
FTE-115-01-G-DV-ES-XX (SEE NOTE 6)	FTE-85-D-ES-15-X (SEE NOTE 6)
FTE-120-01-G-DV-ES-A-XX	FTE-85-D-ES-20-A
FTE-120-01-G-DV-ES-XX	FTE-90-D-ES-20

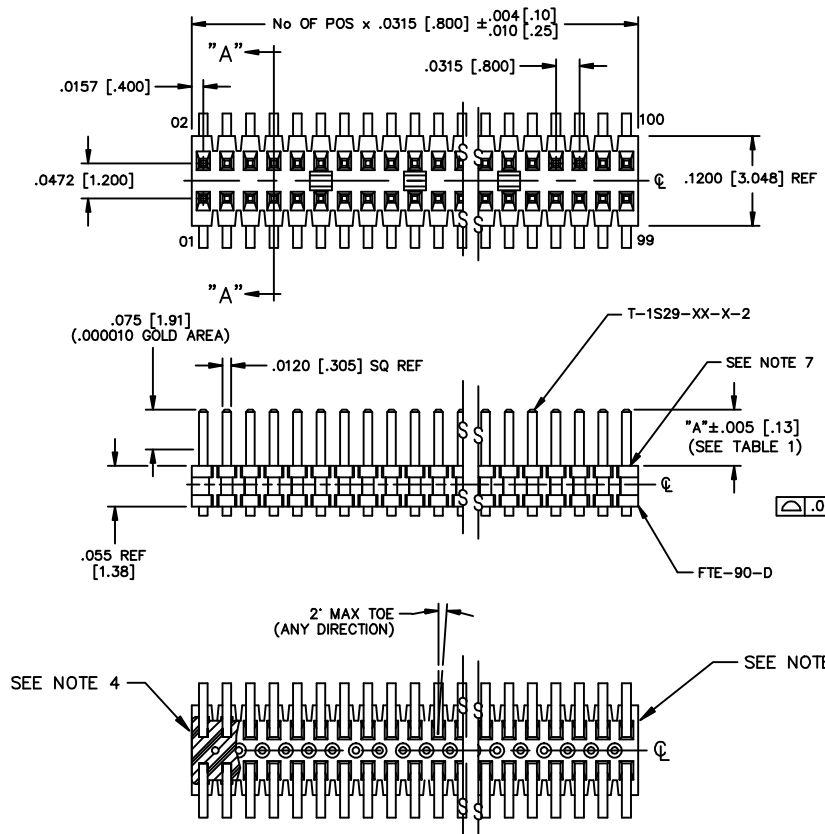

- FTE-1XX-XX-X-DV-XX-XX
- No OF POSITIONS  
-05 THRU -90  
(PER ROW)
- LEAD STYLE SPEC  
-01: .075 POST  
(USE T-1S29-04-X-2 FOR HAND FILL, T-1S29-02-X-2 FOR MACHINE FILL)  
-02: .175 POST  
(USE T-1S29-04-X-2 FOR HAND FILL, T-1S29-02-X-2 FOR MACHINE FILL)  
-03: .120 POST  
(USE T-1S29-04-X-2 FOR HAND FILL, T-1S29-02-X-2 FOR MACHINE FILL)
- PLATING SPEC  
-G: .00010 GOLD ON POST, FLASH GOLD ON REMAINDER
- ROW SPEC  
-DV: DOUBLE ROW VERTICAL  
(USE FTE-90-D)
- OPTIONS  
-P: PICK & PLACE PAD (SEE FIG. 2, SHT 2)  
(ONLY AVAILABLE FOR 08-90 POSITIONS)  
(USE PPP-37)  
(USE PPP-37-NT FOR TAPE & REEL)  
-TR: TAPE & REEL PACKAGING  
(USE PPP-37-NT ONLY)  
-A: ALIGNMENT PIN (MOLDED OR STAKED)  
[SAMTEC DISCRETION ON WHICH -A PIN USED]  
(MOLDED 4 POS MIN, SEE FIG 6, SHT 2)  
(USE FTE-90-D-XX)  
(STAKED 7 POS MIN, SEE FIG 5, SHT 2)  
(USE FTE-90-D-A)  
-M: METAL PICK & PLACE PAD  
(USE MPP-17-5 (SEE FIG 9 SHT 3)  
(10 POS. MIN, AVAILABLE IN -01 STYLE ONLY)
- FLEX SHROUD OPTIONS  
(STYLE -01 ONLY)  
-ES: END SHROUD  
[SAMTEC DISCRETION ON WHICH -ES USED]  
(SEE FIG 3, SHT 2 FOR SNAPPED-ON,  
11 POSITIONS PER ROW MIN)  
(SEE FIG 8, SHT 2 FOR MOLDED,  
5 POSITIONS PER ROW MIN)  
(SEE TABLE 2)  
-EC: END SHROUD WITH  
LOCKING CLIPS  
(SEE FIG. 7, SHT. 2)  
(11 POSITIONS PER ROW MIN)  
-EP: END SHROUD WITH  
GUIDE POSTS  
(SEE FIG. 4, SHT2)  
(11 POSITIONS PER ROW MIN)

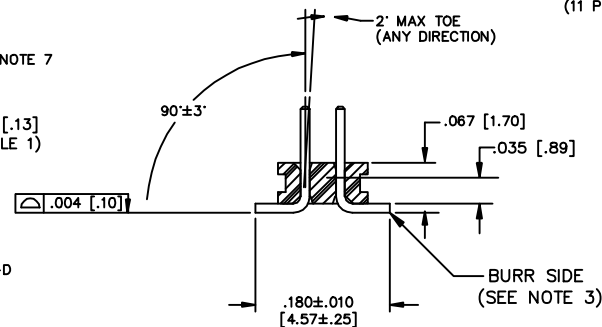

LEAD STYLE	POST HEIGHT
-01	.075
-02	.175
-03	.120

MATERIAL:  
BODY: VECTRA E130  
COLOR: BLACK  
MAX BOW ALLOWED: .002 [.05]  
MAX FLASH ALLOWED: .002 [.05]  
MAX GATE VESTIGE ALLOWED: .002 [.05]

**samtec**

520 PARK EAST BLVD. NEW ALBANY, INDIANA 47150  
PHONE (812) 944-6733 P.O. BOX 1147  
CODE 55322

**PROPRIETARY NOTE**  
THIS DOCUMENT CONTAINS INFORMATION CONFIDENTIAL AND PROPRIETARY TO SAMTEC INC. AND SHALL NOT BE REPRODUCED OR TRANSMITTED IN ANY FORM OR BY ANY MEANS, ELECTRONIC OR MECHANICAL, INCLUDING PHOTOCOPYING, RECORDING, OR BY ANY INFORMATION STORAGE AND RETRIEVAL SYSTEM, WITHOUT THE EXPRESS WRITTEN CONSENT OF SAMTEC INC.