

REVISION DJ

DO NOT SCALE FROM THIS PRINT

- NOTES:
1. PARTS MAY BE CUT TO POSITION.
 2. SHEAR TAILS TO DIMENSION SHOWN.
 3. MEASURED AT BEND RADIUS, NOT AT END OF PIN.
 4. TUBE ONLY -04 THROUGH -50 POSITIONS (SEE TABLE 2).
 5. GOLD PLATING TO BE ON POST, TIN PLATING TO BE ON TAIL.
 6. (C) REPRESENTS A CRITICAL DIMENSION.
 7. MINIMUM PUSHOUT FORCE: 1.0 LB.
 8. .003" MAX BURR ALLOWANCE
 9. .010 [25] MAX CUT FLASH
 10. NOTE DELETED.
 11. NOTE DELETED.

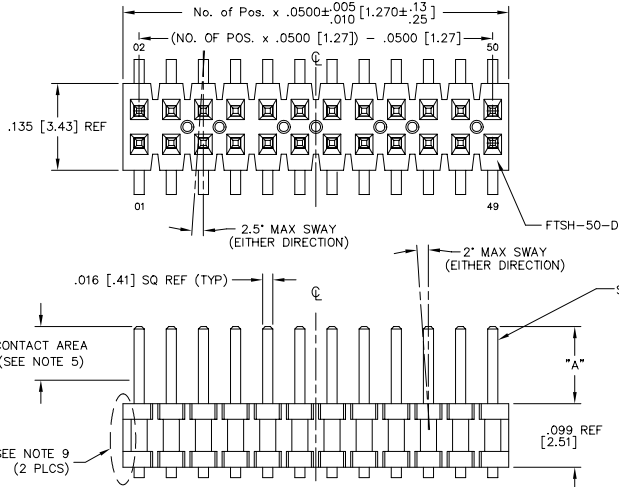

TABLE 2 (SEE SHEET 4 FOR TUBE PACKAGING VIEW)

OPTION(S)	PACKAGING TUBE	TUBE PLUG
NONE, -A (-04 LEAD STYLE)	PT-1-24-04-15	TP-09 (2 REQ'D)
NONE, -A (-01, -02 LEAD STYLES)	PT-1-24-03-43	TP-24 (2 REQ'D)
NONE, -A (-03 LEAD STYLE)	PT-1-24-01-43	TP-24 (2 REQ'D)
-P (-01 LEAD STYLE)	PT-1-24-02-17	TP-09 (2 REQ'D)
-K-A-P, -K-P (-01 LEAD STYLE ONLY)	PT-1-24-03-38	TP-03 (2 REQ'D)
-K-P (-04 LEAD STYLE)	PT-1-24-06-29	TP-07 (2 REQ'D)
-K, -K-A (FOR -01 LEAD STYLE ONLY)	PT-1-24-05-38	TP-09 (2 REQ'D)
-ES (-03, -04 STYLES)	PT-1-24-03-09	TP-03 (2 REQ'D)
-ES-P, -P (-02, -03, -04 STYLES)		
-EC, -EC-P, -EL-P		
-ES-A, -ES-A-P	PT-1-24-04-09	TP-03 (2 REQ'D)
-EP, -EP-A, -EP-P, -EP-A-P		
-EJ, -EJ-K-P, -EJ-P	PT-1-24-02-70	TP-07 (2 REQ'D)
-EJ-A, -EJ-K-A, -EJ-K-A-P, -EJM, -EJC	PT-1-24-01-106	TP-07 (2 REQ'D)
-EPC, -EPC-D, -EPC-P	PT-1-24-04-09	TP-03 (2 REQ'D)
-EL, -EL-A, -EL-A-P	PT-1-24-04-09	TP-03 (2 REQ'D)
-EJ-A, -EJ-K-A, -EJ-K-A-P, -EJM, -EJC	PT-1-24-05-09	TP-03 (2 REQ'D)
-ES (-02 LEAD STYLE)	PT-1-24-01-55	TP-24 (2 REQ'D)
-A-P (-01, -04 LEAD STYLES)	PT-1-24-04-09	TP-03 (2 REQ'D)
-A-P (-02, -03 LEAD STYLES)	PT-1-24-03-09	TP-03 (2 REQ'D)

FIG. 1

PATENT NUMBERS
5713755 / 5961339

UNLESS OTHERWISE NOTED TOLERANCES ARE:

ONE PLACE DECIMALS ± .1[2.54] THREE PLACE DECIMALS ± .005[.13] ANGLES ± 1°

TWO PLACE DECIMALS ± .01[.25] FOUR PLACE DECIMALS ± .0010[.025]

TITLE: .050 [1.27] x .050 [1.27] DOUBLE VERTICAL SMT TERMINAL STRIP

DWG NO: FTSH-1XX-XX-XX-DV-XXX SHEET 1 OF 4

- FTSH-1XX-XX-XX-DV-XXX
- NO. OF POS. -02 THRU -50 (PER ROW)
- LEAD STYLE
- 01: .120 [3.05] (SEE TABLE 1)
 - 02: .075 [1.91] (SEE TABLE 1)
 - 03: .065 [1.65] (SEE TABLE 1)
 - 04: .150 [3.81] (SEE TABLE 1)
- PLATING
- L: LIGHT SELECTIVE
 - F: FLASH SELECTIVE
 - S: SELECTIVE
 - H: HEAVY GOLD
 - SM: HEAVY SELECTIVE GOLD, MATTE TIN TAIL
 - LM: LIGHT SELECTIVE GOLD, MATTE TIN TAIL
 - FM: FLASH SELECTIVE GOLD, MATTE TIN TAIL
 - LT: LIGHT GOLD, TIN LEAD TAILS
- TAIL OPTION
- DV: DOUBLE VERTICAL (USE FTSH-50-D)
- OPTIONS
- P: PICK & PLACE PAD (4 POS MIN) (SEE SHT 2, TABLE 5)
 - TR: TAPE & REEL PACKAGING
 - ES: END SHROUDS (SEE FIG. 2, SHT 2) (MOLDED IN -DN 5 POS MIN; -02 & -03 LEAD STYLE ONLY) (SNAP SHROUDS 9 POS MIN; -02 & -03 LEAD STYLE ONLY)
 - EA: EJECTOR SHROUDS (SEE FIG. 7, SHT 2) (10 POS MIN; -01 LEAD STYLE ONLY)
 - EAM: EJECTOR SHROUDS WITH MOLDED ALIGNMENT PIN (SEE FIG. 8, SHT 2) (10 POS MIN; -01 LEAD STYLE ONLY) (NOT VALID WITH -A OPTION)
 - EUC: EJECTOR SHROUDS WITH LOOKING CLIP (SEE FIG. 8, SHT 2) (10 POS MIN; -01 LEAD STYLE ONLY) (NOT VALID WITH -A OPTION)
 - EC: LOOKING CLIP (SEE FIG. 4, SHT 2) (9 POS MIN; -02 & -03 LEAD STYLE ONLY)
 - EP: GUIDE POST (SEE FIG. 9, SHT 2) (9 POS MIN; -02 & -03 LEAD STYLE ONLY) (USE ONLY WHEN MATING WITH CLP)
 - EL: BOARD LOCK (SEE FIG. 8, SHT 2) (9 POS MIN; -02 & -03 LEAD STYLE ONLY) (USE ONLY WHEN MATING WITH CLP)
 - EPC: GUIDE POST & LOOKING CLIP (SEE FIG. 11, SHT 3) (9 POS MIN; -02 & -03 LEAD STYLE ONLY) (USE ONLY WHEN MATING WITH CLP) (NOT VALID WITH -A OPTION)
 - A: ALIGNMENT PIN (MOLDED OR STAKED) (SEE FIG. 12 & 13, SHT. 3) (MOLDED: 3 POSITION MIN, STAKED: 6 POSITION MIN) (SHARPE DISCRETION ON WHICH -A PIN USE)
 - K: KEYING OPTION FOR MATING WITH FFD (SEE TABLE 3, SHEET 3) (05 THRU 25 AVAILABLE AS STANDARD. (POSITION 13, 17, 20 & 25 AVAILABLE WITH ANY END SHROUD OPTION) (LEAD STYLE -01 ONLY, SEE FIG. 10, SHT 3) (ALIGNMENT PIN AVAILABLE WITH -K OPTION BUT MUST BE MOLDED)
 - *-M: METAL PICK & PLACE PAD (5 POS MIN) (USE MPP-22-5) (SEE FIG. 15, SHT 4) (NOT AVAILABLE WITH -K OPTION)
 - = NOT ENGINEERING APPROVED

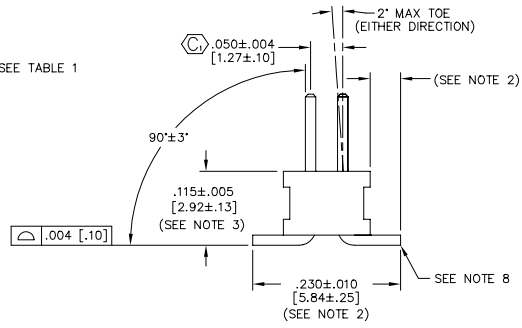

TABLE 1

LEAD STYLE	"A"	AUTOMATED BKT	HAND FILL	MICRO HEADER
-01	.120 [3.05]	T-1S15-03-XXX	T-1S40-03-XX-2	T-1S40-03-XX-2
-02	.075 [1.91]	T-1S15-03-XXX	T-1S15-03-XXX	NOT AVAILABLE
-03	.065 [1.65]	T-1S15-03-XXX	T-1S15-03-XXX	NOT AVAILABLE
-04	.150 [3.81]	T-1S15-03-XXX	T-1S15-03-XXX	NOT AVAILABLE

MATERIAL:
INSULATOR:
BLACK LIQUID CRYSTAL POLYMER

TERMINAL:
PHOSPHOR BRONZE



520 PARK EAST BLVD. NEW ALBANY, INDIANA 47150
PHONE: (812) 944-6733 P.O. BOX 1147
CODE 55322

MADE BY: PURVIS 10-12-95 FTSH-1XX-XX-XX-DV-XXX SHEET 1 OF 4