

REVISION CW

NOTES:

- MINIMUM PUSHOUT FORCE TO BE 12 OZ RETENTION FOR CONTACTS AND WELD TABS.
- COPLANARITY: .004[.10] = POS 02 THRU 26
.006[.15] = POS 27 THRU 50
- MANUFACTURING IN PROCESS DIMENSION DESIGNED TO ACHIEVE FINAL ASSEMBLY.
- ⊙ REPRESENTS A CRITICAL DIMENSION.
- [] DIMENSIONS ARE IN MILLIMETERS.
- MEASURED FROM BEND.
- DIMENSION CHANGED PER REVISION AD.
CONTACT ENGINEERING FOR INFORMATION.
- SIDES OF PLASTIC BODIES ON ALL LEAD STYLES EXCEPT THE -01 & -02 WILL BE SOLID, NOT RIBBED.
- MEASURE FROM TIPS OF PIN.
- NOTE DELETED.
- .003[.08] MAXIMUM TERMINAL BURR.
- .005 MAXIMUM HEIGHT VARIATION BETWEEN ANY TWO PINS.
- MINIMUM LOCKING CLIP RETENTION TO BE 8 OZS.
- THIS FEATURE ONLY PRESENT ON -01 & -02 LEAD STYLES.

DO NOT SCALE FROM THIS PRINT

CW TFM-1XX-XX-XXX-X-XXX

No OF POSITIONS
LEAD STYLE -01: (-5 THRU -50 ALL POSITIONS AVAILABLE)
LEAD STYLE -02: (-5 THRU -50 ALL POSITIONS AVAILABLE)
ALL OTHER LEAD STYLES: (-5 THRU -50 MULTIPLES OF 5)
LEAD STYLES -11, -12 POS 12, 16, 17 ALSO AVAILABLE
LEAD STYLES -21, -22, -31, -32 POS 12 AND 13 ALSO AVAILABLE

LEAD STYLE
THROUGH HOLE SURFACE MOUNT
-01 (SEE FIG. 1) -02 (SEE FIG. 2)
-11 (SEE FIG. 1) -12 (SEE FIG. 2)
-21 (SEE FIG. 1) -22 (SEE FIG. 2)
-31 (SEE FIG. 1) -32 (SEE FIG. 2)

PLATING SPECIFICATION
-S: SELECTIVE
-L: LIGHT SELECTIVE
-F: FLASHED GOLD
-P: GOLD FLASHED PALLADIUM NICKEL
-G: GOLD
-H: HEAVY GOLD
-SM: SELECTIVE HEAVY GOLD, MATTE TIN TAIL
-LM: SELECTIVE LIGHT GOLD, MATTE TIN TAIL
-FM: SELECTIVE FLASH GOLD, MATTE TIN TAIL
-STL: SELECTIVE TIN LEAD

BODY SPECIFICATION
-D: DOUBLE ROW

OPTION
-A: ALIGNMENT PIN (USE TFM-XX-D-XX-A, SEE FIG. 8 SHEET 3) (NOT AVAILABLE FOR -RA OR -RE)
-LC: LOCKING CLIP (USE LC-05-TM) (NOT AVAILABLE FOR -RA OR -RE) (SEE FIG. 10 SHEET 3) (SEE NOTE 13)
-P: PICK AND PLACE PAD (USE PPP-04) (AVAILABLE IN ALL POSITIONS) (NOT AVAILABLE FOR -RA OR -RE, SEE FIG. 7 SHEET 3)
-RA: RIGHT ANGLE (AVAILABLE ONLY IN LEAD STYLE: -01 SEE FIG. 5, SHEET 2)
-TR: TAPE AND REEL (SEE FIG. 4, SHEET 5)
-SA: STAKED ALIGNMENT PIN (SEE FIG. 9, SHEET 3) (NOT AVAILABLE FOR -RA OR -RE)
-K: POLYIMIDE FILM (SEE FIG. 3)
-WT: WELD TABS (USE WT-25-XX-T) (AVAILABLE ON -01 AND -02 LEAD STYLES ONLY) (SEE FIG. 4 SHEET 2) (AVAILABLE ON -05, -07, -10, -15, -20, -25, AND -30 POS ONLY) (AVAILABLE WITH -L AND -S PLATING ONLY) (NOT AVAILABLE WITH -A, -LC, -RA, OR -SA OPTIONS)
*RE1: RIGHT ANGLE ELEVATED .062 PCB (USE TFM-XX-D-01-RE, NOT AVAILABLE WITHOUT -WT, AVAILABLE IN LEAD STYLE -01 ONLY, AVAILABLE IN -5 THRU -30 POSITIONS ONLY) (SEE FIG. 11, SHEET 4)
*RE2: RIGHT ANGLE ELEVATED .093 PCB (USE TFM-XX-D-01-RE, NOT AVAILABLE WITHOUT -WT, AVAILABLE IN LEAD STYLE -01 ONLY, AVAILABLE IN -5 THRU -30 POSITIONS ONLY) (SEE FIG. 12, SHEET 4)

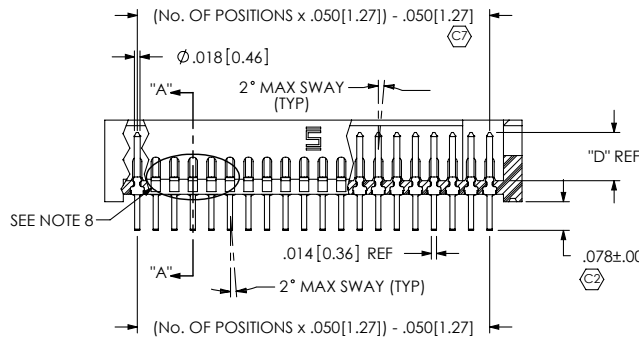
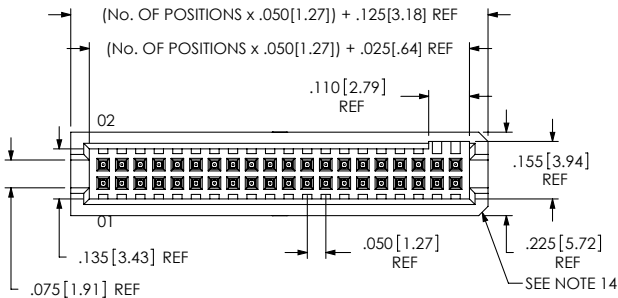
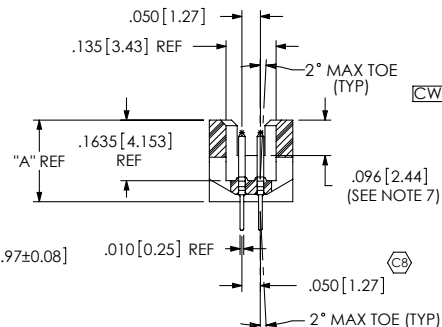
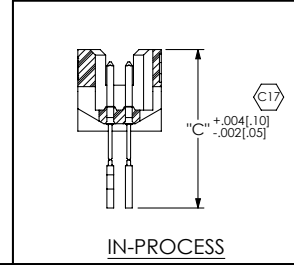

FIGURE 1 THROUGH HOLE -01, -11, -21, -31



SECTION "A"- "A"

CW * = NOT RELEASED FOR PRODUCTION



IN-PROCESS

UNLESS OTHERWISE SPECIFIED, DIMENSIONS ARE IN INCHES. TOLERANCES ARE:
DECIMALS .XX: ±.01 [3]
.XXX: ±.005 [13]
.XXXX: ±.0020 [051]
ANGLES 2°
PROPRIETARY NOTE
THIS DOCUMENT CONTAINS INFORMATION CONFIDENTIAL AND PROPRIETARY TO SAMTEC, INC. AND SHALL NOT BE REPRODUCED OR TRANSMITTED TO OTHER DOCUMENTS OR DISCLOSED TO OTHERS OR USED FOR ANY PURPOSE OTHER THAN THAT WHICH IT WAS OBTAINED WITHOUT THE EXPRESSED WRITTEN CONSENT OF SAMTEC, INC.

samtec
520 PARK EAST BLVD, NEW ALBANY, IN 47150
PHONE: 812-944-6733 FAX: 812-948-5047
e-Mail: info@SAMTEC.com code: 53522

CW

TABLE 1									
LEAD STYLE	BODY	"A"	TERMINAL 1	TERMINAL 1 "B"	TERMINAL 2	TERMINAL 2 "B"	"C"	"D"	"E"
-01, -02	TFM-XX-D-01-XX	.2200 [5.688]	T-1R16-01-XX-2	0.015 [38]	N/A	N/A	0.427 [10.88]	0.133 [3.38]	0.230 [5.84]
-11, -12	TFM-XX-D-02-XX	.2900 [7.366]	T-1R20-03-XX	0.030 [76]	N/A	N/A	0.644 [16.36]	0.130 [3.30]	0.300 [7.62]
-21, -22	TFM-XX-D-03-XX	.3600 [9.144]	T-1R20-04-XX	0.100 [2.54]	N/A	N/A	0.644 [16.36]	0.130 [3.30]	0.370 [9.40]
-31, -32	TFM-XX-D-04-XX	.4350 [11.049]	T-1R20-02-XX	0.175 [4.45]	N/A	N/A	0.644 [16.36]	0.130 [3.30]	0.445 [11.30]
-01-RA	TFM-XX-D-01-XX	.2200 [5.688]	T-1R16-02-XX	0.035 [89]	T-1R16-03-XX	0.083 [2.11]	N/A	0.133 [3.38]	0.230 [5.84]
-01-RE1	TFM-XX-D-01-RE	.2400 [6.096]	T-1R16-06-XX	0.035 [89]	T-1R16-07-XX	0.083 [2.11]	N/A	0.133 [3.38]	N/A
-01-RE2	TFM-XX-D-01-RE	.2400 [6.096]	T-1R16-08-XX	0.035 [89]	T-1R16-09-XX	0.083 [2.11]	N/A	0.133 [3.38]	N/A

MATERIAL: DO NOT SCALE DRAWING SHEET SCALE: 2.5:1
INSULATOR: LIQUID CRYSTAL POLYMER, COLOR: BLACK
TERMINAL: PHOSPHOR BRONZE

DESCRIPTION: .050 X .050 TERMINAL STRIP
DWG. NO. CW TFM-1XX-XX-XXX-X-XXX
BY: B RAY 7-10-2007 SHEET 1 OF 5

F:\DWG\SW\Exisprod\ASSEMBLY\050\TFM-1XX-XX-XXX-X-XXX.SLDDRW

REVISION CW

FIGURE 2
THROUGH HOLE
-02, -12, -22, -32
(DIFFERENT AS SHOWN, OTHERWISE SAME AS FIG. 1)

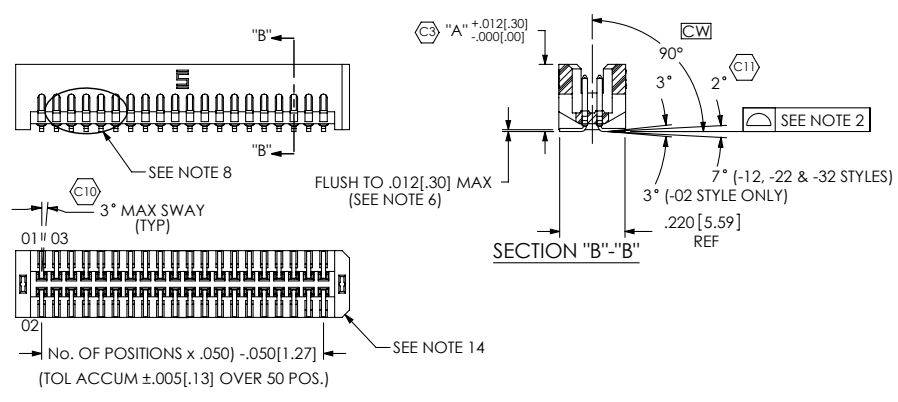

FIGURE 3
-K: POLYIMIDE FILM PAD

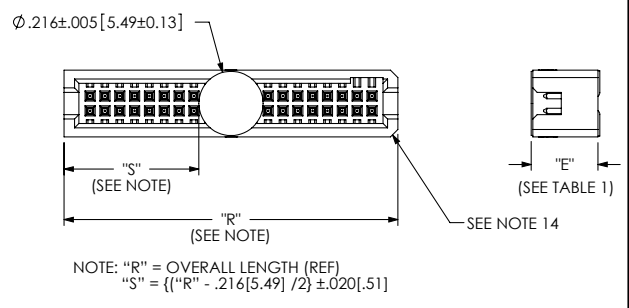

FIGURE 5
-RA OPTION
(DIFFERENT AS SHOWN, OTHERWISE SAME AS FIG. 1)

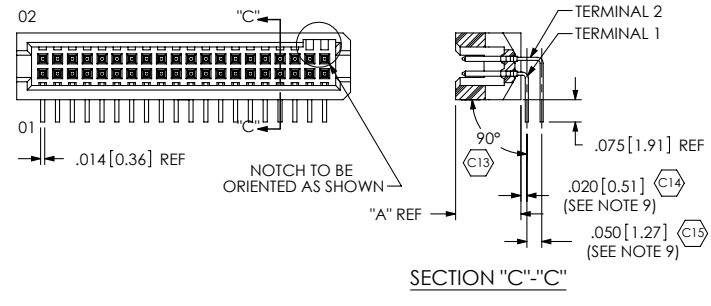
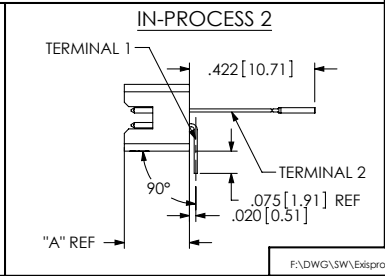
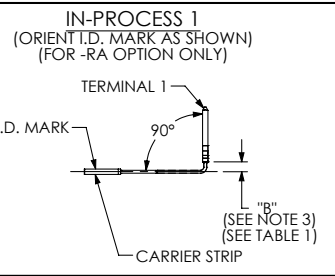
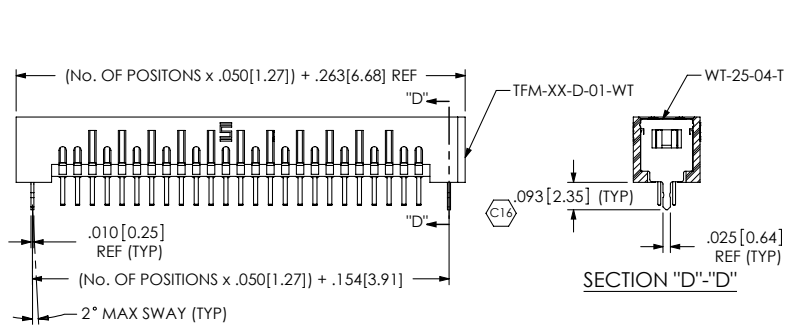

FIGURE 6
-WT OPTION
(DIFFERENT AS SHOWN, OTHERWISE SAME AS FIG. 1)



PROPRIETARY NOTE
THIS DOCUMENT CONTAINS INFORMATION CONFIDENTIAL AND PROPRIETARY TO SAMTEC, INC. AND SHALL NOT BE REPRODUCED OR TRANSFERRED TO OTHER DOCUMENTS OR DISCLOSED TO OTHERS OR USED FOR ANY PURPOSE OTHER THAN THAT WHICH IT WAS OBTAINED WITHOUT THE EXPRESSED WRITTEN CONSENT OF SAMTEC, INC.

DO NOT SCALE DRAWING

SHEET SCALE: 2:1

samtec
520 PARK EAST BLVD, NEW ALBANY, IN 47150
PHONE: 812-944-6733 FAX: 812-948-5047
e-Mail: info@SAMTEC.com code: 55322

DESCRIPTION: .050 X .050 TERMINAL STRIP

DWG. NO. **TFM-1XX-XX-XXX-X-XXX**

BY: B RAY 7-10-2007 SHEET 2 OF 5

F:\DWG\SW\Esprod\ASSEMBLY\050\TFM-1XX-XX-XXX-X-XXX.SLDDRW

REVISION CW

FIGURE 7

-P OPTION
DIFFERENT AS SHOWN, OTHERWISE SAME AS FIG. 1
(PAD TO BE POSITIONED ON C.L. AS SHOWN)

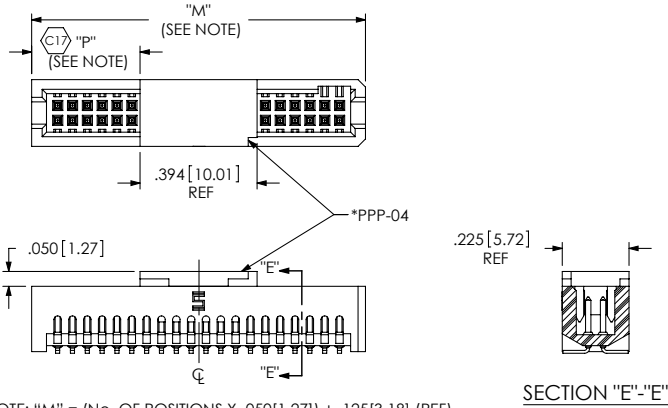

NOTE: "M" = (No. OF POSITIONS X $.050 [1.27]$) + $.125 [3.18]$ (REF)
"P" = $\{ ("M" - .394 [10.01]) / 2 \} \pm .020 [5.1]$

* NOTCH ON PAD FOR 10 POSITION OR LESS TO BE ON SAME END AS THE NOTCH IN THE TFM BODY

FIGURE 8

-A OPTION
DIFFERENT AS SHOWN, OTHERWISE SAME AS FIG. 1

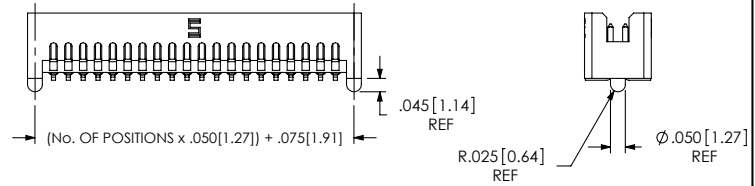

FIGURE 9

-SA OPTION: STAKED ALIGNMENT PIN
DIFFERENT AS SHOWN, OTHERWISE SAME AS FIG. 1

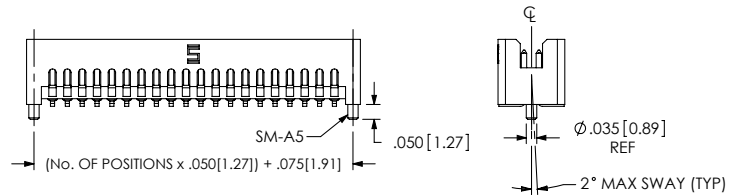
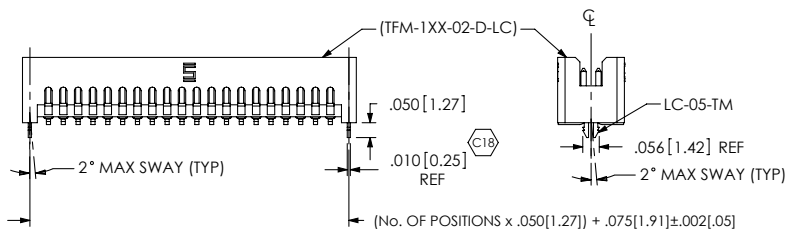
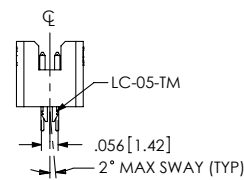

FIGURE 10

-LC OPTION
DIFFERENT AS SHOWN, OTHERWISE SAME AS FIG. 1
(NOT AVAILABLE ON -RA)



(TFM-1XX-01-D-LC) CW



PROPRIETARY NOTE

THIS DOCUMENT CONTAINS INFORMATION CONFIDENTIAL AND PROPRIETARY TO SAMTEC, INC. AND SHALL NOT BE REPRODUCED OR TRANSFERRED TO OTHER DOCUMENTS OR DISCLOSED TO OTHERS OR USED FOR ANY PURPOSE OTHER THAN THAT WHICH IT WAS OBTAINED WITHOUT THE EXPRESSED WRITTEN CONSENT OF SAMTEC, INC.

DO NOT SCALE DRAWING

SHEET SCALE: 2:1

samtec

520 PARK EAST BLVD, NEW ALBANY, IN 47150
PHONE: 812-944-6733 FAX: 812-948-5047
e-Mail: info@SAMTEC.com code: 55322

DESCRIPTION: **.050 X .050 TERMINAL STRIP**

DWG. NO. **TFM-1XX-XX-XXX-X-XXX**

BY: B RAY 7-10-2007 SHEET 3 OF 5

F:\DWG\SW\E6sprod\ASSEMBLY\050\TFM-1XX-XX-XXX-X-XXX.SLDDRW

REVISION CW

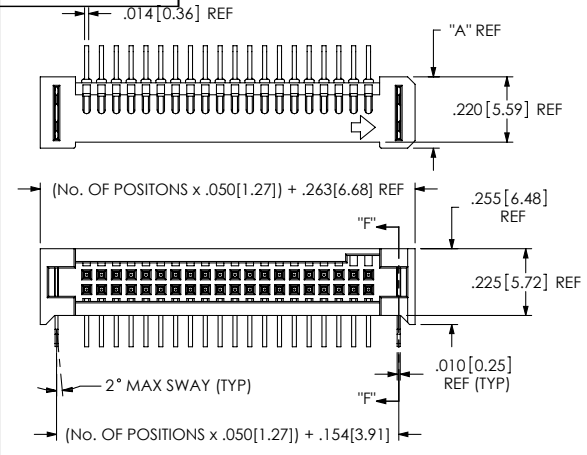

FIGURE 11
 -RE1: RIGHT ANGLE ELEVATED .062 PCB
 DIFFERENT AS SHOWN, OTHERWISE SAME AS FIG. 1
NOT RELEASED FOR PRODUCTION

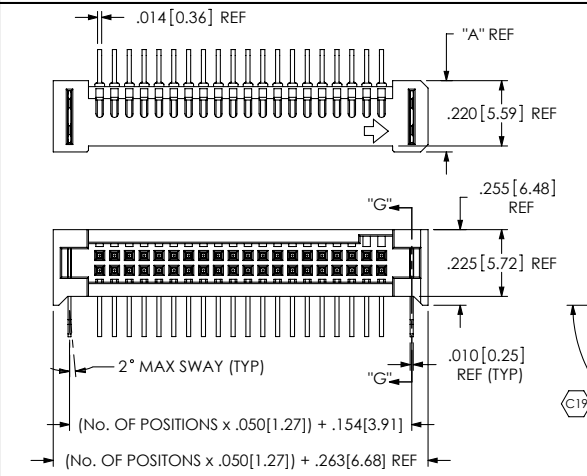
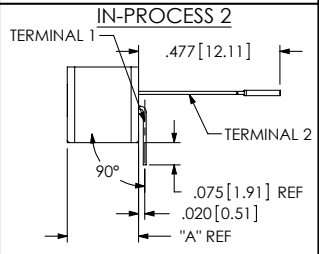
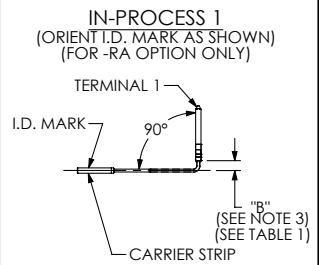
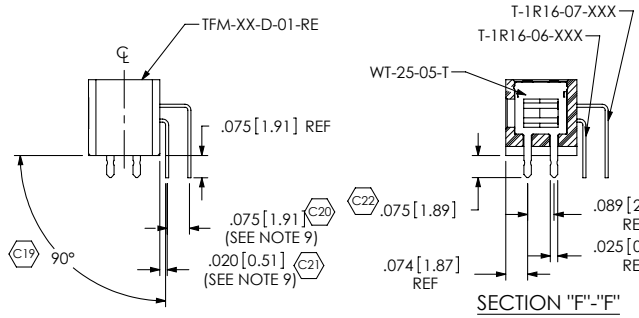
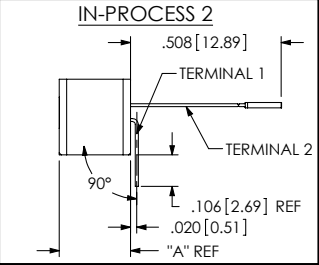
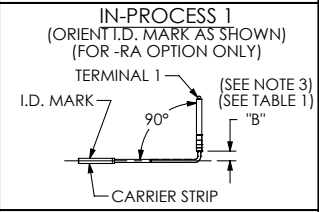
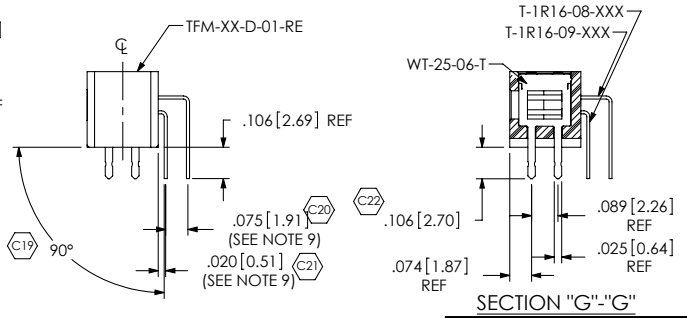

FIGURE 12
 -RE2: RIGHT ANGLE ELEVATED .093 PCB
 DIFFERENT AS SHOWN, OTHERWISE SAME AS FIG. 1
NOT RELEASED FOR PRODUCTION



PROPRIETARY NOTE
 THIS DOCUMENT CONTAINS INFORMATION
 CONFIDENTIAL AND PROPRIETARY TO
 SAMTEC, INC. AND SHALL NOT BE REPRODUCED
 OR TRANSFERRED TO OTHER DOCUMENTS OR
 DISCLOSED TO OTHERS OR USED FOR ANY
 PURPOSE OTHER THAN THAT WHICH IT WAS
 OBTAINED WITHOUT THE EXPRESSED WRITTEN
 CONSENT OF SAMTEC, INC.

DO NOT SCALE DRAWING

SHEET SCALE: 2:1

samtec
 520 PARK EAST BLVD, NEW ALBANY, IN 47150
 PHONE: 812-944-6733 FAX: 812-948-5047
 e-Mail: info@SAMTEC.com code: 55322

DESCRIPTION: .050 X .050 TERMINAL STRIP

DWG. NO. TFM-1XX-XX-XXX-X-XXX

BY: B RAY 7-10-2007 SHEET 4 OF 5

F:\DWG\SW\E6sprod\ASSEMBLY\050\TFM-1XX-XX-XXX-X-XXX.SLDDRW

REVISION CW

PARTS TO BE PACKAGED IN TUBES AS SHOWN

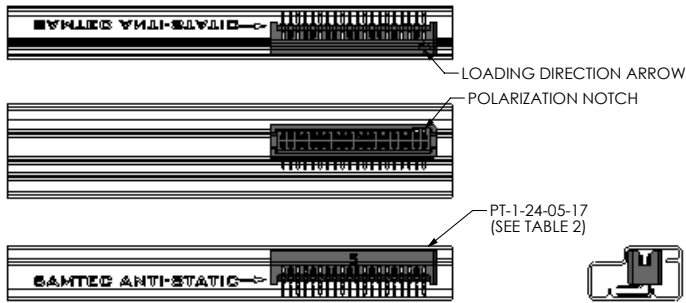
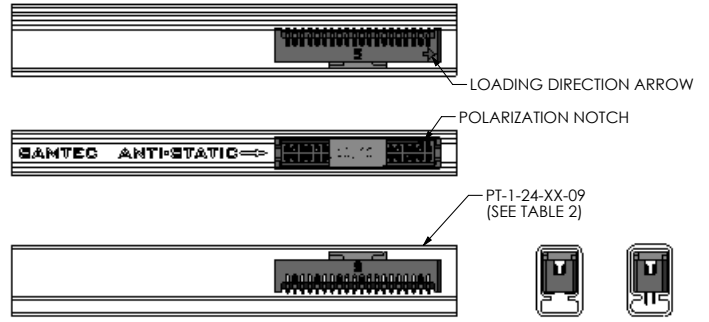
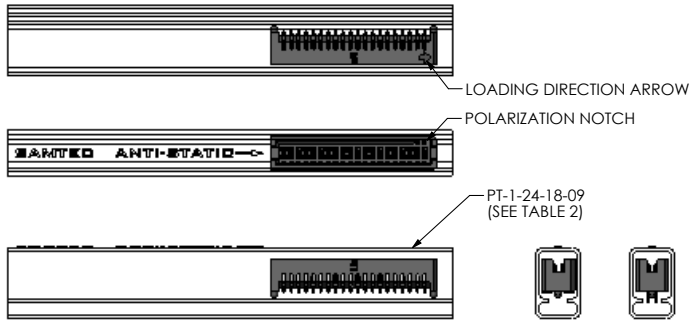

FIGURE 4
-TR: TAPE AND REEL

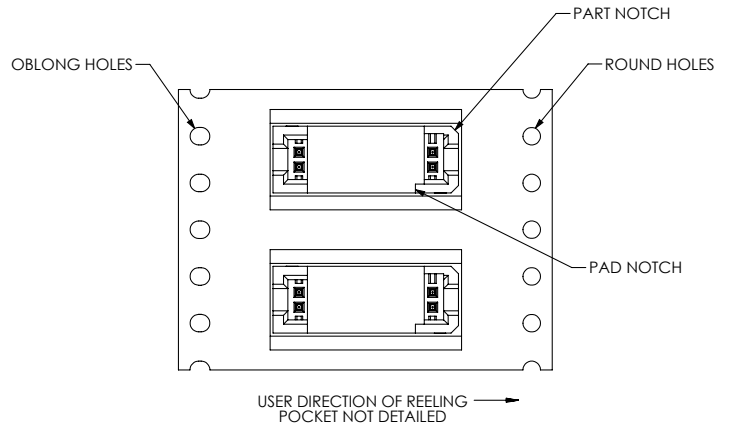

TABLE 2

LEAD STYLE	PACKAGING TUBE	PLUG
-RA (ALL LEAD STYLES)	PT-1-24-5-17	TP-07
-REX	PT-1-24-03-38	TP-03
-02, -02-A, -02-A-K, -02-LC	PT-1-24-01-09	TP-24
-12 (ALL OPTIONS), -22-K, -22, -22-A, -22-A-K, -22-LC, -22-LC-K	PT-1-24-04-09	TP-07
-02-A-P, -02-K, -02-LC-K, -02-LC-P, -02-P, -02-WT,	PT-1-24-18-09	TP-09
-01 (ALL OPTIONS), -11, -11-A, -11-LC, -11-K, -11-LC-K, -11-A-K		
-31-A-K, -31-A-P, -31-LC-P, -31-P, -32, -32-K, -32-A, -32-A-K,	PT-1-24-02-09	TP-07
-32-A-P, -32-LC-K, -32-LC-P, -32-P		
-31, -21-P, -22-P, -31-LC, -21-A-P, -21-LC-P, -22-LC-P, -31-A,	PT-1-24-05-09	TP-07
-32-LC, -22-A-P, -31-LC-K, -31-K		
-11-P, -11-LC-P, -11-A-P, -21, -21-K, -21-A, -21-LC, -21-A-K, -21-LC-K	PT-1-24-20-09	TP-07

NOTE:
PARTS TO BE PACKAGED WITH THE LOADING DIRECTION ARROW
POINTED IN SAME DIRECTION AS THE ARROW ON TUBE.

PROPRIETARY NOTE
THIS DOCUMENT CONTAINS INFORMATION
CONFIDENTIAL AND PROPRIETARY TO
SAMTEC, INC. AND SHALL NOT BE REPRODUCED
OR TRANSFERRED TO OTHER DOCUMENTS OR
DISCLOSED TO OTHERS OR USED FOR ANY
PURPOSE OTHER THAN THAT WHICH IT WAS
OBTAINED WITHOUT THE EXPRESSED WRITTEN
CONSENT OF SAMTEC, INC.

samtec

520 PARK EAST BLVD, NEW ALBANY, IN 47150
PHONE: 812-944-6733 FAX: 812-948-5047
e-Mail: info@SAMTEC.com code: 55322

DO NOT SCALE DRAWING

SHEET SCALE: 2:1

DESCRIPTION: .050 X .050 TERMINAL STRIP

DWG. NO. TFM-1XX-XX-XXX-X-XXX

BY: B RAY 7-10-2007 SHEET 5 OF 5

F:\DWG\SW\E6sprod\ASSEMBLY\050\TFM-1XX-XX-XXX-X-XXX.SLDDRW