

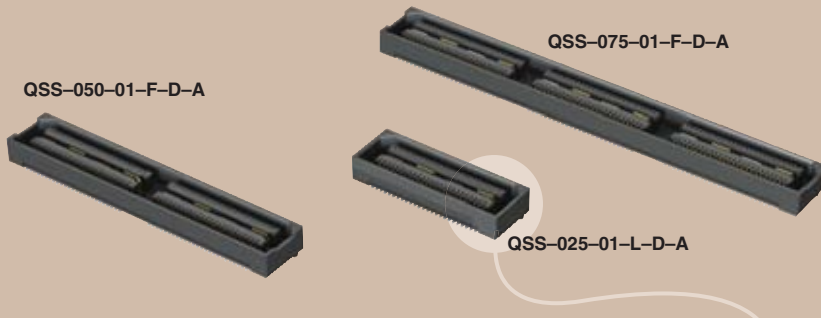

(0,635mm) .025"

QSS SERIES



# HIGH SPEED GROUND PLANE SOCKET

## SPECIFICATIONS

For complete specifications and recommended PCB layouts see [www.samtec.com?QSS](http://www.samtec.com?QSS)

**Insulator Material:** Liquid Crystal Polymer  
**Contact Material:** Phosphor Bronze  
**Plating:** Au or Sn over 50µ" (1,27µm) Ni  
**Current Rating:** Contact: 1.1A @ 30°C  
 Temperature Rise Ground Plane: 7.8A @ 30°C  
 Temperature Rise  
**Operating Temp:** -55°C to +125°C  
**Voltage Rating:** 285 VAC  
**Max Cycles:** 100  
**RoHS Compliant:** Yes



5mm Stack Height	Type	Rated @ 3dB Insertion Loss
Single-Ended Signaling	-D	9 GHz / 18 Gbps
Differential Pair Signaling	-D	8.5 GHz / 17 Gbps
Differential Pair Signaling	-DP	8.5 GHz / 17 Gbps

Performance data for other stack heights and complete test data available at [www.samtec.com?QSS](http://www.samtec.com?QSS) or contact [sig@samtec.com](mailto:sig@samtec.com)

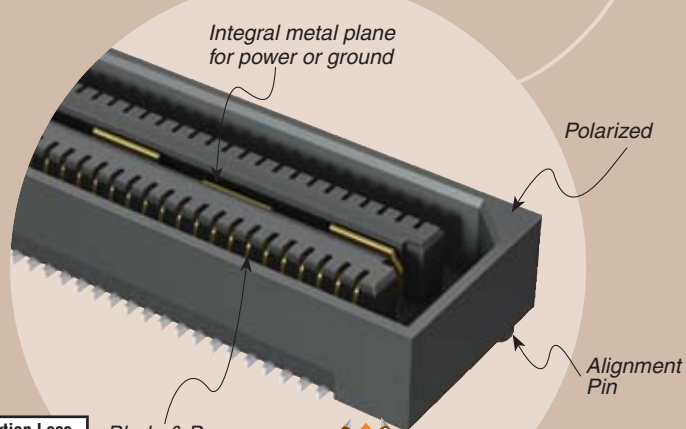

ALSO AVAILABLE

• Board spacing standoffs (See SO Series)

**Processing:** Lead-Free Solderable: Yes

**SMT Lead Coplanarity:** (0,10mm) .004" max (025-050) (0,15mm) .006" max (75-100)  
**Board Stacking:** For applications requiring more than two connectors per board or 100 positions or higher, contact [ipg@samtec.com](mailto:ipg@samtec.com)

## APPLICATION SPECIFIC OPTION

- 11mm & 16mm stack height (Caution: Some automatic placement/inspection machines may have component height restrictions. Please consult machinery specifications.)
  - 30µ" (0,76µm) Gold
  - Differential Pair and "Partitionable" (combine differential & single-ended banks in same connector) available.
  - 125 positions per row
  - Edge Mount
  - Locking screw hole for QTS-RA-LS2
- Call Samtec.

\*Note: -C Plating passes 10 year MFG testing

Note: Some lengths, styles and options are non-standard, non-returnable.



**-025, -050, -075, -100**  
 (50 total positions per bank)

**-F**  
 = Gold Flash on Signal Pins and Ground Plane, Matte Tin on tails

**-L**  
 = 10µ" (0,25µm) Gold on Signal Pins and Ground Plane, Matte Tin on tails

**-C\***  
 = Electro-Polished Selective 50µ" (1,27µm) min Au over 150µ" (3,81µm) Ni on Signal Pins in contact area, 10µ" (0,25µm) min Au over 50µ" (1,27µm) Ni on Ground Plane in contact area, Matte Tin over 50µ" (1,27µm) min Ni on all solder tails

**-GP**  
 = Guide Holes for mating with QTS-RA

**-K**  
 = (8,25mm) .325" DIA Polyimide Film Pick & Place Pad

**-TR**  
 = Tape and Reel (-075 positions maximum)

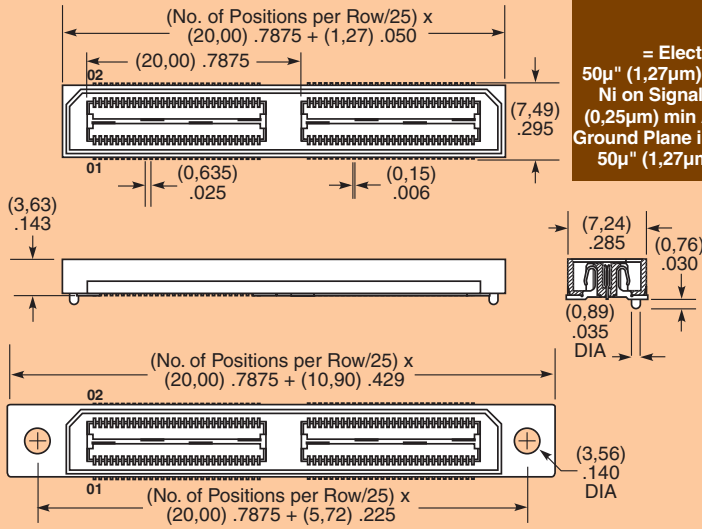

Due to technical progress, all designs, specifications and components are subject to change without notice.

WWW.SAMTEC.COM