

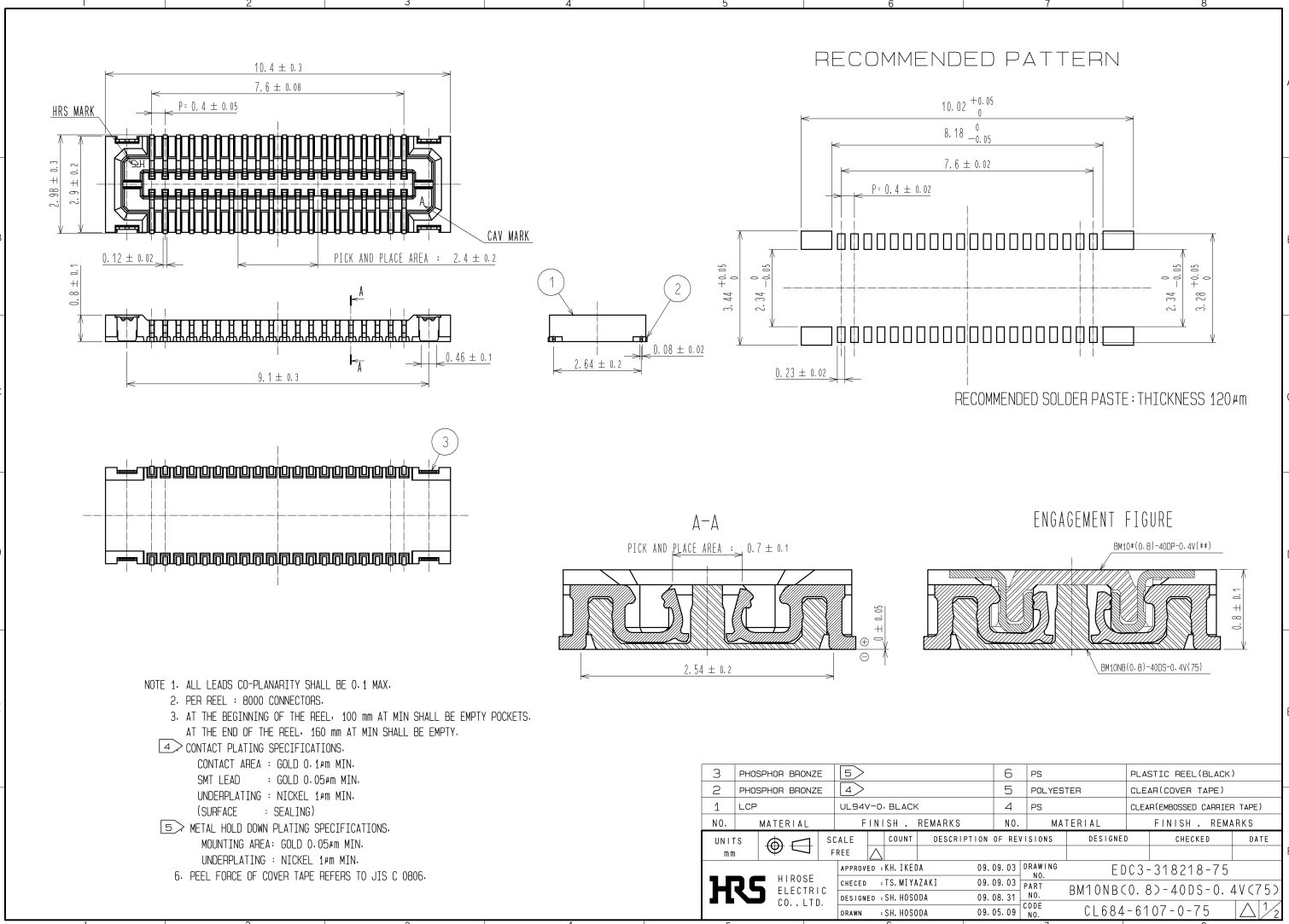

DRAWING FOR REFERENCE: This is subject to change without notice

2010/01/12 08:16:06 CAROL TRIBBLE



FORM H20011-5-7

3	PHOSPHOR BRONZE	5		6	PS	PLASTIC REEL (BLACK)		
2	PHOSPHOR BRONZE	4		5	POLYESTER	CLEAR (COVER TAPE)		
1	LCP	UL94V-0- BLACK		4	PS	CLEAR (EMBOSSED CARRIER TAPE)		
NO.	MATERIAL	FINISH	REMARKS	NO.	MATERIAL	FINISH	REMARKS	
UNITS	mm	SCALE	FREE	COUNT	DESCRIPTION OF REVISIONS	DESIGNED	CHECKED	DATE
<b>HRS</b> HIROSE ELECTRIC CO., LTD.		APPROVED : KH. IKEDA	09.09.03	DRAWING NO.	EDC3-318218-75			
		CHECKED : TS. MIYAZAKI	09.09.03	PART NO.	BM10NB(0.8)-40DS-0.4V(75)			
		DESIGNED : SH. HOSODA	09.08.31	CODE NO.	CL684-6107-0-75			
		DRAWN : SH. HOSODA	09.05.09					

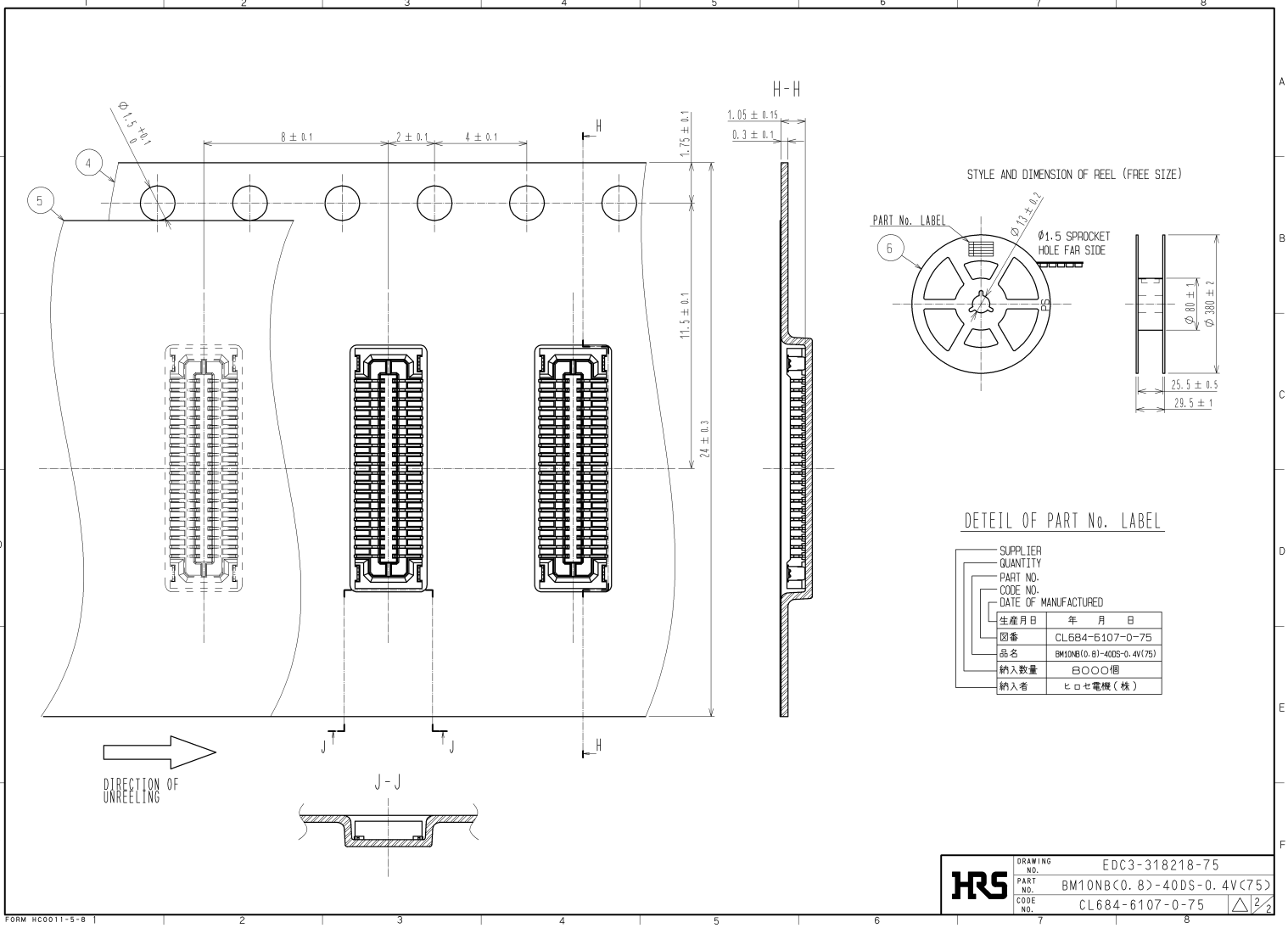

DETAIL OF PART No. LABEL

SUPPLIER	
QUANTITY	
PART NO.	
CODE NO.	
DATE OF MANUFACTURED	
生産月日	年 月 日
図番	CL684-6107-0-75
品名	BM10NB(0.8)-40DS-0.4V(75)
納入数量	8000個
納入者	ヒロセ電機(株)

<b>HRS</b>	DRAWING NO.	EDC3-318218-75
	PART NO.	BM10NB(0.8)-40DS-0.4V(75)
	CODE NO.	CL684-6107-0-75
		$\triangle$ $\frac{2}{2}$